

F892

8 Segment Redundant Fieldbus Power Supply
for use with non-proprietary cabled systems

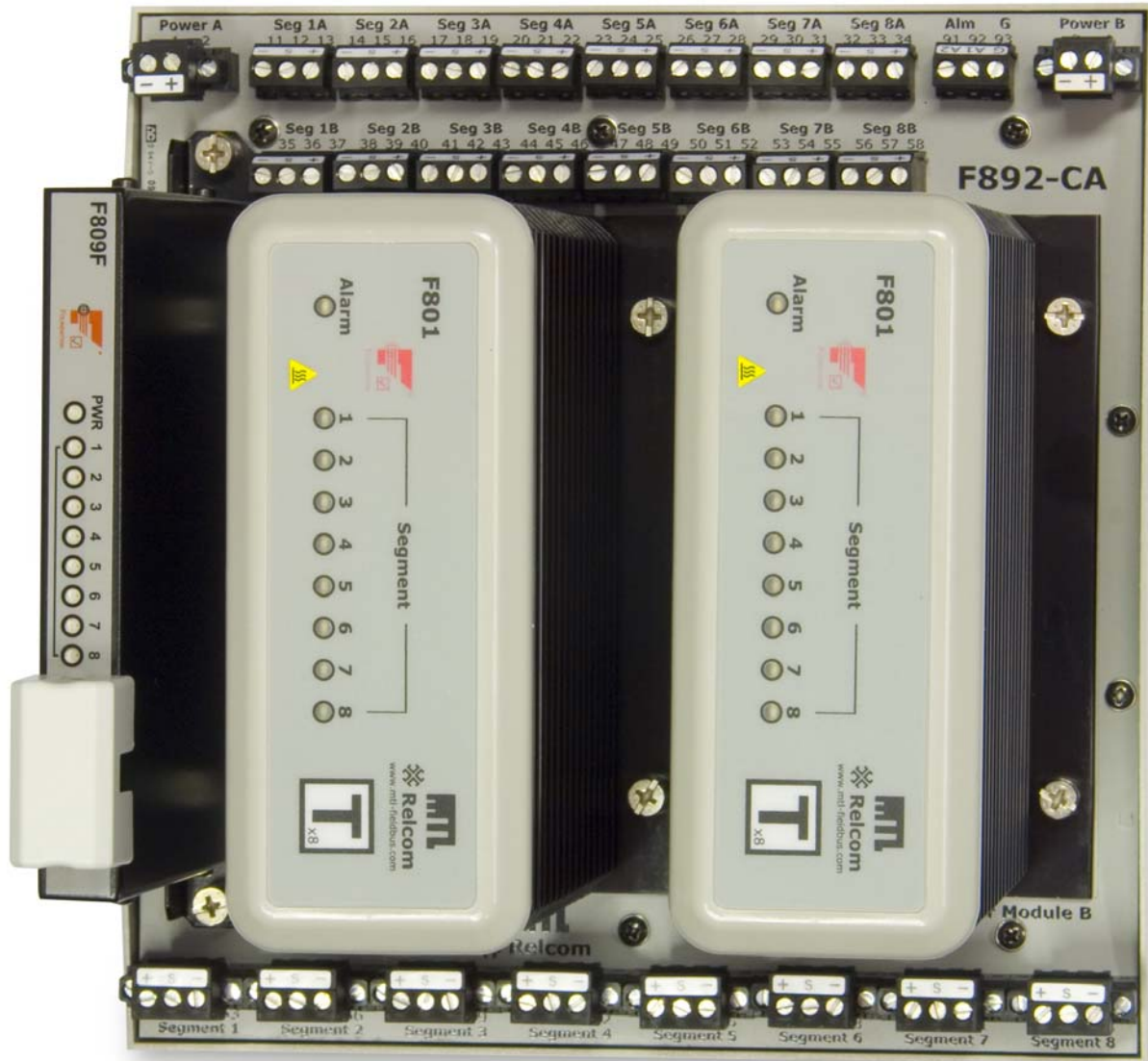

F892-PS

Installation Instructions

CONTENTS

PAGE

1	OVERVIEW	1
2	DESCRIPTION	1
3	COMPONENTS AND ACCESSORIES	2
4	MECHANICAL	3
4.1	Mounting Orientation	3
4.2	Enclosure Requirements	3
4.2.1	General Requirements	3
4.2.2	Outdoor Mounting	3
4.3	DIN-rail Mounting	3
4.3.1	Mounting Procedure	3
4.4	Removal from DIN-rail	3
4.5	Mounting and Removal of F801 Power Modules	3
5	ELECTRICAL CONNECTIONS	4
5.1	DC Power Requirements	4
5.2	Power A and Power B	4
5.2.1	Redundancy	4
5.2.2	Terminator	4
5.3	Alarm Connection	4
5.4	Host Connections	5
5.5	Field Segment Connections	5
5.6	Cable Screen / Ground Connections	5
5.7	Chassis Ground Connection	5
5.8	Diagnostic Segment Connection	5
6	TESTING	6
6.1	F801 Status and Alarm LEDs	6
7	ROUTINE MAINTENANCE	6
8	EMC COMPLIANCE SUMMARY	7
9	FM CONTROL DRAWINGS	8
10	ATEX CATEGORY 3 INSTRUCTIONS	10

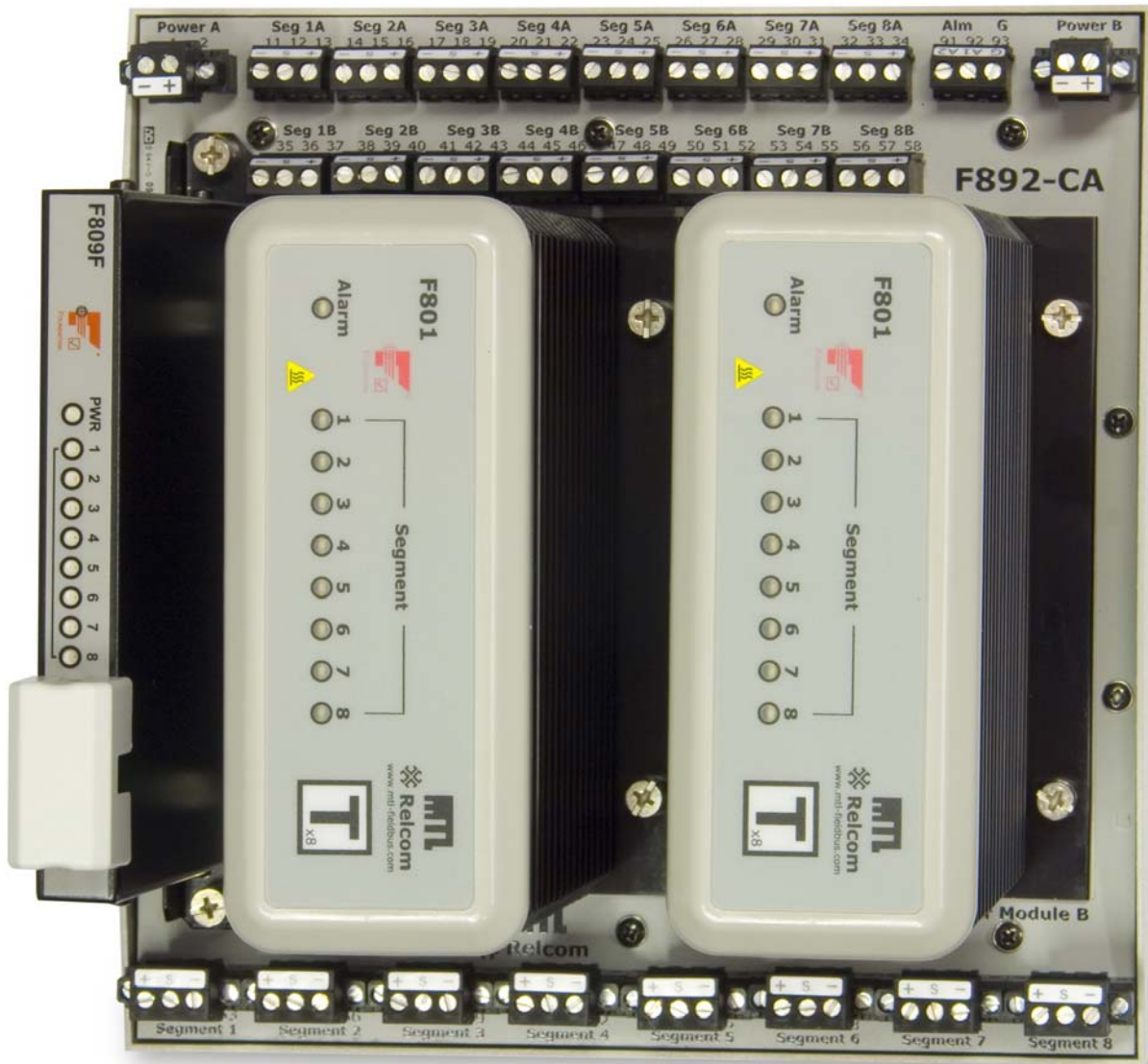

Figure 1: F892-PS

1 OVERVIEW

The F892 redundant fieldbus power supply is designed to provide redundant power for eight (8) Foundation fieldbus™ H1 segments. Pluggable connectors are provided on the F892-CA module carrier for connection to the eight segments. Fixed screw terminals are used for the 8 Host segment connections. Power for the eight fieldbus segments is provided by two F801 or F802 Power Modules mounted to the carrier and operating in a redundant configuration. Failure alarms, galvanic isolation, power conditioning and segment termination are incorporated into each Power Module. A single F801 or F802 module may be used where redundancy is not required.

2 DESCRIPTION

For maximum reliability, the module carrier contains no components and only provides interconnections between the

power modules and the external connections. The carrier circuit board is supported in a rigid metal frame that protects it from mechanical damage. Secure DIN-rail mounting is provided by integrated retaining screws. The Power Module provides galvanic isolation between the 24V DC input power and the fieldbus segments, as required by the IEC61158-2 fieldbus standard and the Fieldbus Foundation™ FF-831 validation test for fieldbus power supplies. There is also galvanic isolation between the fieldbus segments, thereby preventing cross-talk between segments in the event of ground faults in the field wiring. Each segment has its own current limitation and passive fieldbus power conditioner. Termination of the fieldbus segment is automatically maintained when single or redundant Power Modules are fitted. The F892-CA carrier is equipped with connectors that will accept an F809F diagnostic module. The module continuously monitors the performance of each of the eight fieldbus segments, providing information on the network health.

Each Power Module has indicator LEDs to show both its status and that of the eight segments under power. In normal operation, each green 'Segment' LED is lit, showing

that the segment is powered. If a segment is shorted, or its voltage is below the rated output, its LED is extinguished, and the red 'Alarm' LED is lit. Redundant 24V DC (nom.) input power is connected to the F892-CA carrier using two-part pluggable connectors. Field wiring connections are available with either pluggable screw terminals (F892-PS) or pluggable spring clamp terminals (F892-PC).

The figure below shows two sets of 8 connectors for connection to the Host. Early versions of the F892 only included one set of connectors (unit date code 0711 and earlier) and thus did not support redundant Host connection.

3 COMPONENTS AND ACCESSORIES

Product part numbers and their descriptions are given to the right.

PART No.	DESCRIPTION
F801	8 Segment Power Module: 21.5V, 350mA
F802	8 Segment Power Module: 28V, 500mA
F809F	8 Segment Fieldbus Diagnostic Module
F892-CA-P*	Carrier
F892-P*	F892-CA-P* and two F801 modules
F892-2-P*	F892-CA-P* and two F802 modules
F892-P*-NR	F892-CA-P* and one F801 module
F892-2-P*-NR	F892-CA-P* and one F802 module
F800-BLK	Blanking Module included with -NR systems

* = S – Pluggable Screw Terminal Connectors
C – Pluggable Spring Clamp Connectors

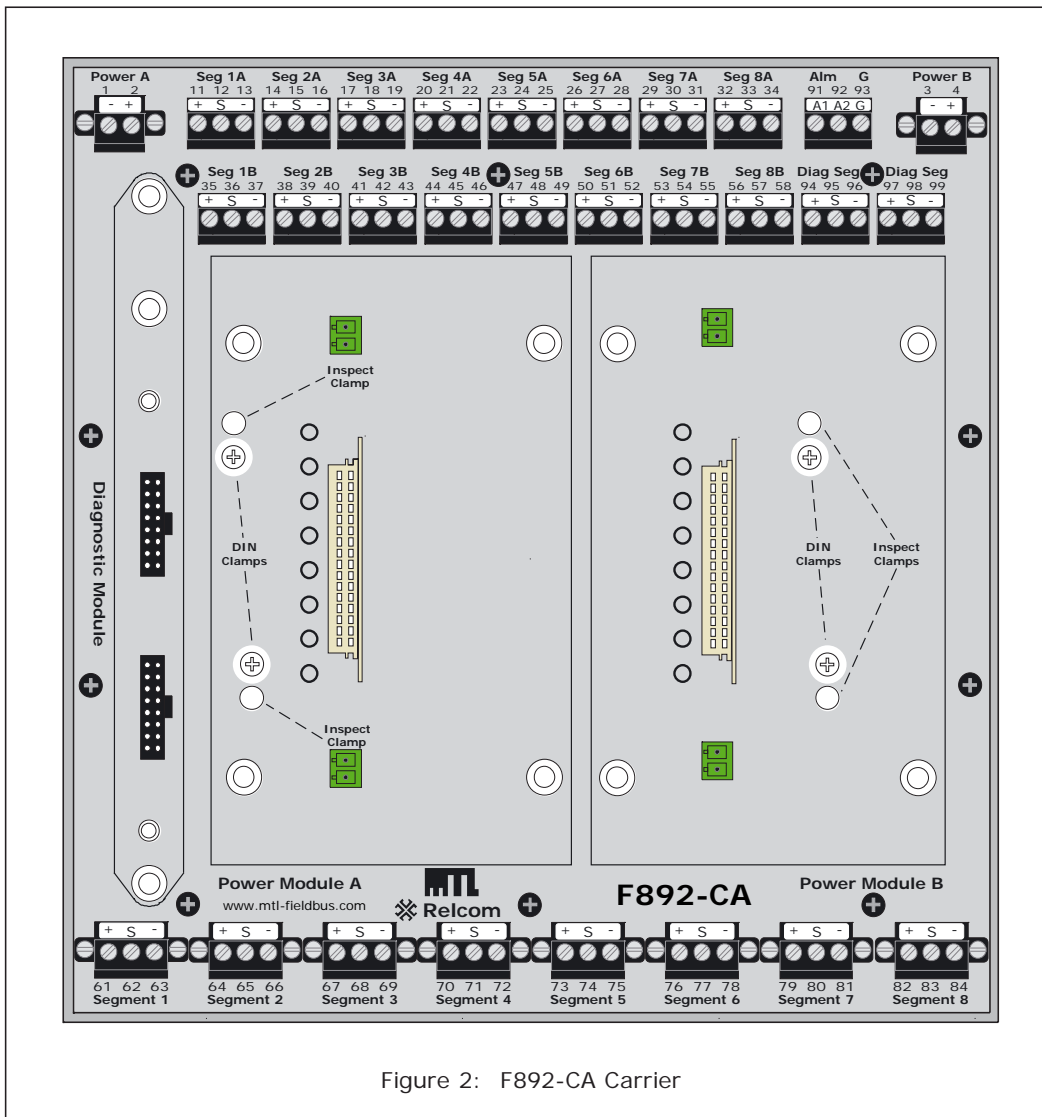

Figure 2: F892-CA Carrier

Drawing shows carrier of date code 0712 or later with two rows of eight host segment connectors. Carriers with date codes 0711 or earlier are only provided with a single row of eight connectors. Also, only carriers with date codes after 0726 include the Diagnostic Segment connectors. See sections 5.4 and 5.8 for further details.

4 MECHANICAL

4.1 Mounting Orientation

The F892-CA carriers are designed for mounting on a horizontally aligned DIN-rail on a vertical surface. This method of mounting ensures optimum heat dissipation from the F801 Power Modules.

4.2 Enclosure Requirements

4.2.1 General Requirements

The assembly may be mounted in Hazardous (classified) areas – see Section 9. The following conditions must also be satisfied to ensure safe and reliable operation.

- Prevent any form of pollution that could compromise the operation of the unit. For example, choose an unpolluted location or a suitable enclosure to protect the assembly.
- Provide an adequate level of mechanical protection. This can be achieved by selecting a protected location, a suitable enclosure, or a combination of both.
- Ensure that all cable entries and connections are secure by making provision for the careful routing and securing of all cables.
- Provide adequate security against unauthorized interference.
- Ensure that the permitted ambient temperature range of -40°C to $+65^{\circ}\text{C}$ (derate to $+50^{\circ}\text{C}$ for the F802 when loaded above 60% of its full load rating) is not exceeded. Allow for power dissipation within the enclosure and consider the use of shading against direct sunlight.

4.2.2 Outdoor Mounting

If the power system is mounted in an outdoor location, use a suitable enclosure with a minimum of IP54 ingress protection. A higher level of ingress protection rating will be necessary if the working atmosphere is or can be corrosive or if the enclosure is subject to wet or dusty environments.

4.3 DIN-rail Mounting

The carrier is designed for mounting on 35mm x 7.5mm T-section "top hat" DIN rail to EN50022 and uses six built-in DIN clamp tabs to hold it on the rail. The Power Modules must be removed from the carrier to obtain access to the DIN-rail clamp screws.

4.3.1 Mounting Procedure

Before starting to mount the carrier on the DIN rail, rotate all four of the **DIN clamp** screws counterclockwise (i.e. unscrew) until the clamping tabs reach the position shown in Figure 3a and none of the tabs extend into the channel for the DIN rail.

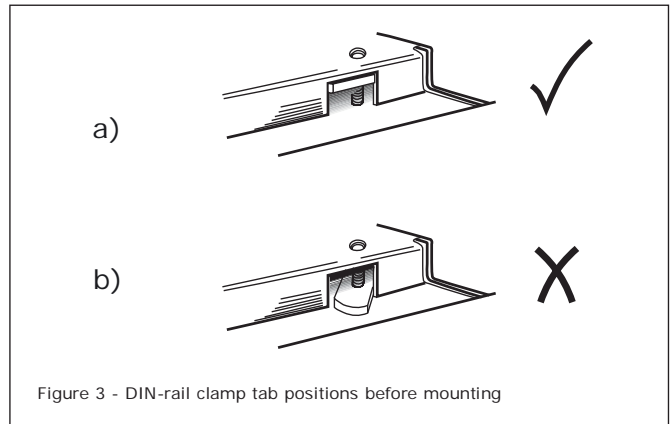

Press the carrier onto the DIN-rail and rotate each of the **DIN clamp** screws clockwise until the tab tightens against the DIN-rail. The clamping tabs can be seen through the **Inspect clamps** holes when they are in the correct position.

4.4 Removal from DIN-rail

The Power Modules must be removed from the carrier to obtain access to the DIN-rail clamp screws. Support the carrier by pressing it to the DIN-rail and unscrew (counterclockwise) the four DIN-rail clamp screws. Turn each screw approximately two full turns when releasing its clamping tab from the rail. Remove carrier.

4.5 Mounting and Removal of the Power Modules

The Power Modules are secured to the carrier with four screw mountings. There are four locating connectors (two for each Power Module) on the module carrier along with mating connectors in the F801 or F802 module. Align the module with the retaining screws and press onto the connector. Hold it in place while tightening the four retaining screws. To remove a Power Module, support the module while unscrewing the four retaining screws at its base. Lift the module off the carrier connector.

Note: Earlier versions of the module carriers do not have locating connectors. Align using the retaining screws furthest from the module connector and rock onto the connector.

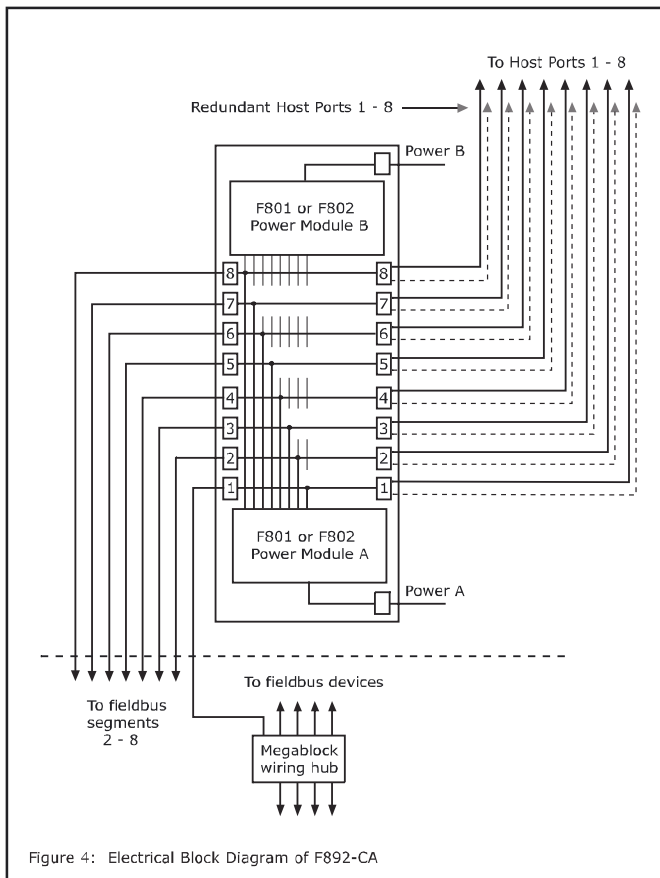

Figure 4: Electrical Block Diagram of F892-CA

5 ELECTRICAL CONNECTIONS

The DC power and Field Segment connectors are pluggable and available in a screw terminal version (-PS) or a spring clamp version (-PC). See Figures 5a & 5b. The terminals can accept the following conductor sizes:

Type	Conductor size
Screw terminals (-PS)	0.14 to 2.5mm ²
Spring clamp terminals (-PC)	0.2 to 2.5mm ²

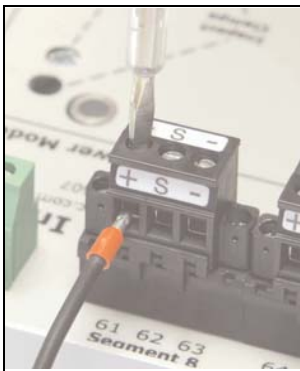

Figure 5a: Screw Terminal

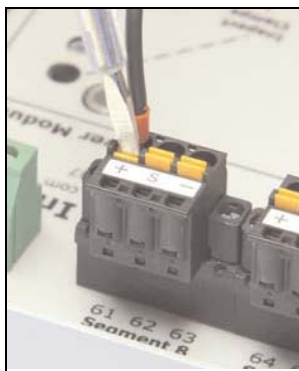

Figure 5b: Spring Clamp

NOTE: When wiring to spring-clamp terminals, use a screwdriver with a 3-4 mm blade and depress the spring-clamp button before inserting the termination cable. See Figure 5b.

5.1 DC Power Requirements

Dual redundant power terminals requiring a nominal input voltage of 24VDC are provided allowing the use of bulk power supplies with a supply range of 19.2–30VDC. Input power cabling and over-current protection devices must be chosen to match the current consumption.

An F892 system, operating with redundant F801 modules at 24VDC, will require 3.5A in total if all eight segments draw the maximum of 350mA. With redundant F802 modules the system will draw 6A when all segments are loaded to 500mA. Note that the total current could be drawn from either the Power A or Power B connection if one power module is removed.

It is also important to size the Bulk Power Supply to handle the inrush current required by the F801 or F802. Inrush is less than 2 times the maximum rated current for the F801 with a duration lasting less than 1ms. For the F802, the inrush is less than 4 times the maximum rated current with a duration less than 10ms.

5.2 Power A and Power B

Power A supplies Power Module A and Power B supplies Power Module B. Each module provides DC power to all eight segments - see Figure 4. DC supply connections are as follows:

Power A	
Pin No.	Connection
2	+ve
1	-ve

Power B	
Pin No.	Connection
4	+ve
3	-ve

Cable lengths on the Power connectors should not exceed 30m.

5.2.1 Redundancy

For **redundant operation**, F801 or F802 modules must be fitted in Power Module A and Power Module B locations. For **non-redundant operation** fit an F801 or F802 in the Power Module A location and apply power to Power A terminals. The F800-BLK would then be placed on the Power Module B connector to allow the alarm circuit to function. Power must be connected to Power B terminals if live replacement of Power Module A is necessary since Power B terminals feed the Power Module B connector.

5.2.2 Terminator

A single terminator is provided automatically on each segment whether one or two Power Modules are used.

5.3 Alarm Connection

In an alarm condition a normally closed, galvanically-isolated relay contact in each Power Module goes to an open-circuit condition. These relays are connected in series on the F892-CA carrier and are presented at terminals as follows:

Alarm	
Pin No.	Connection
91	+ve
92	-ve

In non-redundant applications using a single Power Module, the alarm connections on the carrier will be open-circuit, indicating a permanent alarm condition unless the F800-BLK module is fitted in place of the missing Power Module.

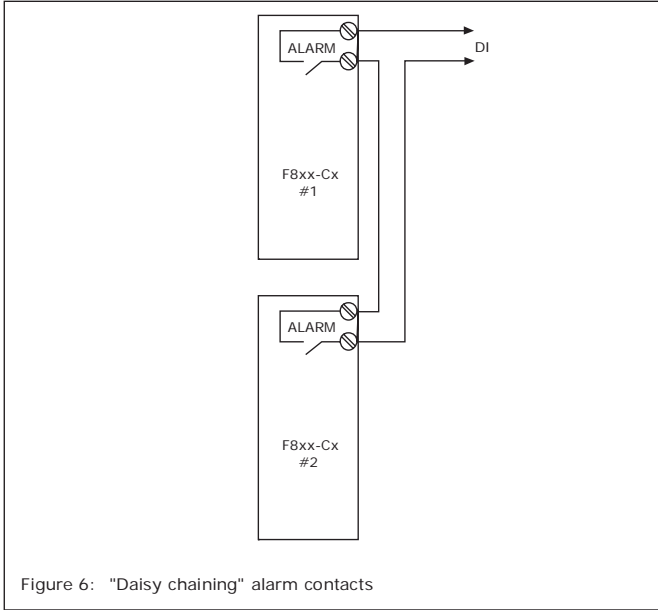

Figure 6: "Daisy chaining" alarm contacts

If multiple F892 units are used, a common alarm circuit can be achieved by 'daisy-chaining' the alarm circuits (see Figure 6).

5.4 Host Connections

For units with date code 0712 and later, there are sixteen Host segment connectors – two rows of eight. Earlier versions only provided one row of eight connectors and thus do not support Redundant Host connection. Use one row for Simplex Host connection, and both rows (where available) for Redundant Host connection.

Host manufacturers support Redundant Host connections differently. For example for the Emerson DeltaV system, the Termblock connects the two Host ports together, so only one connection should be made from the Termblock to the F892 carrier. Other systems such as the ABB 800xA or the Rosemount 3420 use the power supply carrier to make the interconnection between the two redundant H1 ports and therefore require two separate spur connections to the two host cards.

Each connector provides (+), (-) and cable screen (S) connections. The cable screen (S) connections for each segment do NOT link to each other, nor are they connected to a common ground. See section 5.6.

Pin No.	Connection
11,35	Segment 1 +
12,36	Segment 1 S
13,37	Segment 1 -
14,38	Segment 2 +
15,39	Segment 2 S
16,40	Segment 2 -
17,41	Segment 3 +
18,42	Segment 3 S
19,43	Segment 3 -
20,44	Segment 4 +
21,45	Segment 4 S
22,46	Segment 4 -

Pin No.	Connection
23,47	Segment 5 +
24,48	Segment 5 S
25,49	Segment 5 -
26,50	Segment 6 +
27,51	Segment 6 S
28,52	Segment 6 -
29,53	Segment 7 +
30,54	Segment 7 S
31,55	Segment 7 -
32,56	Segment 8 +
33,57	Segment 8 S
34,58	Segment 8 -

The host cable length should not exceed 30 meters.

5.5 Field Segment Connections

There are eight field segment connectors. Each connector provides (+), (-) and cable screen (S) connections. The cable screen (S) connections for each segment do NOT link to each other, nor are they connected to a common ground. See section 5.6.

Pin No.	Connection
61	Segment 1 +
62	Segment 1 S
63	Segment 1 -
64	Segment 2 +
65	Segment 2 S
66	Segment 2 -
67	Segment 3 +
68	Segment 3 S
69	Segment 3 -
70	Segment 4 +
71	Segment 4 S
72	Segment 4 -

Pin No.	Connection
73	Segment 5 +
74	Segment 5 S
75	Segment 5 -
76	Segment 6 +
77	Segment 6 S
78	Segment 6 -
79	Segment 7 +
80	Segment 7 S
81	Segment 7 -
82	Segment 8 +
83	Segment 8 S
84	Segment 8 -

5.6 Cable Screen / Ground Connections

If the screens of the fieldbus cables are required to be earthed in the equipment cabinet housing the F892 system, a separate earth bar, connected to local instrumentation earth, should be used.

5.7 Chassis Ground Connection

The chassis of the carrier should be connected to a Safety or Instrumentation Ground using screw terminal 93. This ground is needed for the F892 system to meet Electromagnetic Compatibility and Electrical Safety requirements.

5.8 Diagnostic Segment Connectors

Two Diagnostic Segment connectors are available for use in conjunction with the optional F809F Diagnostic Module. These connectors are only available on carriers made after date code 0726. Please see the Installation Manual for the F809F for further information.

Pin No.	Connection
94	Diag Seg +
95	Diag Seg S
96	Diag Seg -

Pin No.	Connection
97	Diag Seg +
98	Diag Seg S
99	Diag Seg -

6 TESTING

6.1 F801 / F802 Status and Alarm LEDs

Each Power Module is fitted with nine LEDs, eight to indicate segment status and one to signify an Alarm condition.

Fault Condition	Segment LED	Fault LED	Alarm contact status
No Fault	Green	Off	Closed
Segment shorted	Off	Red	Open
Output <20V	Off	Red	Open
Input <16V	Off (All)	Red	Open

7 ROUTINE MAINTENANCE

Check the general condition of the installation occasionally to make sure that no deterioration has occurred. At least every two years (and more frequently for particularly harsh environments) check:

- the condition of wire connections, terminations, and screens.
- the dc output voltage on each of the eight fieldbus segments is >21.5V for the F801 and >28V for the F802. This can be performed using a multi-meter or a Relcom FBT-3/FBT-6 Fieldbus Monitor.
- the segment LEDs on the Power Module(s) are functioning and the Alarm LED is not lit .
- the Power Module retaining screws are tight.
- there are no signs of damage or corrosion.

8 EMC COMPLIANCE SUMMARY

European Union EMC Tests in accordance with EN61326 EMC Product Family Standard for measurement, control and laboratory equipment.

Test Items: **F890-PS, F890-2-PS**

Other products conforming based on these test results include:

Modules:

F801, F802

Carriers:

F880-CA F880-CL F880-CR F890-CA F892-CA

Above 5 part numbers may include a "-PS" or "-PC" suffix to indicate that Pluggable Screw Terminal or Pluggable Spring Clamp connectors are included with the Carrier.

Carrier/Module Kits:

F880-P* F880-L* F880-R* F890-P* F892-P*
 F880-2-P* F880-2-L* F880-2-R* F890-2-P* F892-2-P*

* = S for Screw Terminal connectors, C for Spring Clamp connectors

Above 5 part numbers may include "-NR" to indicate only 1 Module in the Kit (non-redundant)

European Union Electromagnetic Compatibility (EMC) Tests in accordance with EC Council Directive 2004/108/EC

Emissions Tests per EN61326

Result	Standard	Description	Port	Comments
Pass	EN61326	Radiated Emissions	Enclosure	

Immunity Tests per EN61326 – Industrial locations

Result	Standard	Description	Port	Criteria
Pass	EN61000-4-2	Electrostatic Discharge Immunity	Enclosure	B
Pass	EN61000-4-3	RF Electromagnetic Field Immunity	Enclosure	A
Pass	EN61000-4-4	Electrical Fast Transient/Burst Immunity	DC / IO Port	B
Pass	EN61000-4-5	Electrical Slow Transient Immunity	IO Port	B
Pass	EN61000-4-6	RF Conducted Immunity	DC / IO Port	A

I, Mike Strauser, representative for Relcom Inc., verify that the product tested is representative of production products to be sold.

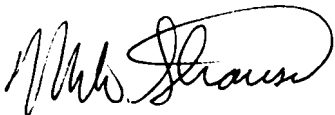

9 FM CONTROL DRAWINGS

HAZARDOUS (CLASSIFIED) LOCATION

Class I, Division 2, Groups A, B, C, D, T4

Class I, Zone 2, IIC T4

-40C <= Tamb <= 65C

-40C <= Tamb <= 50C (F802 total Load > 60% of maximum rating)

TO BE INSTALLED IN AN IP 54 OR BETTER ENCLOSURE

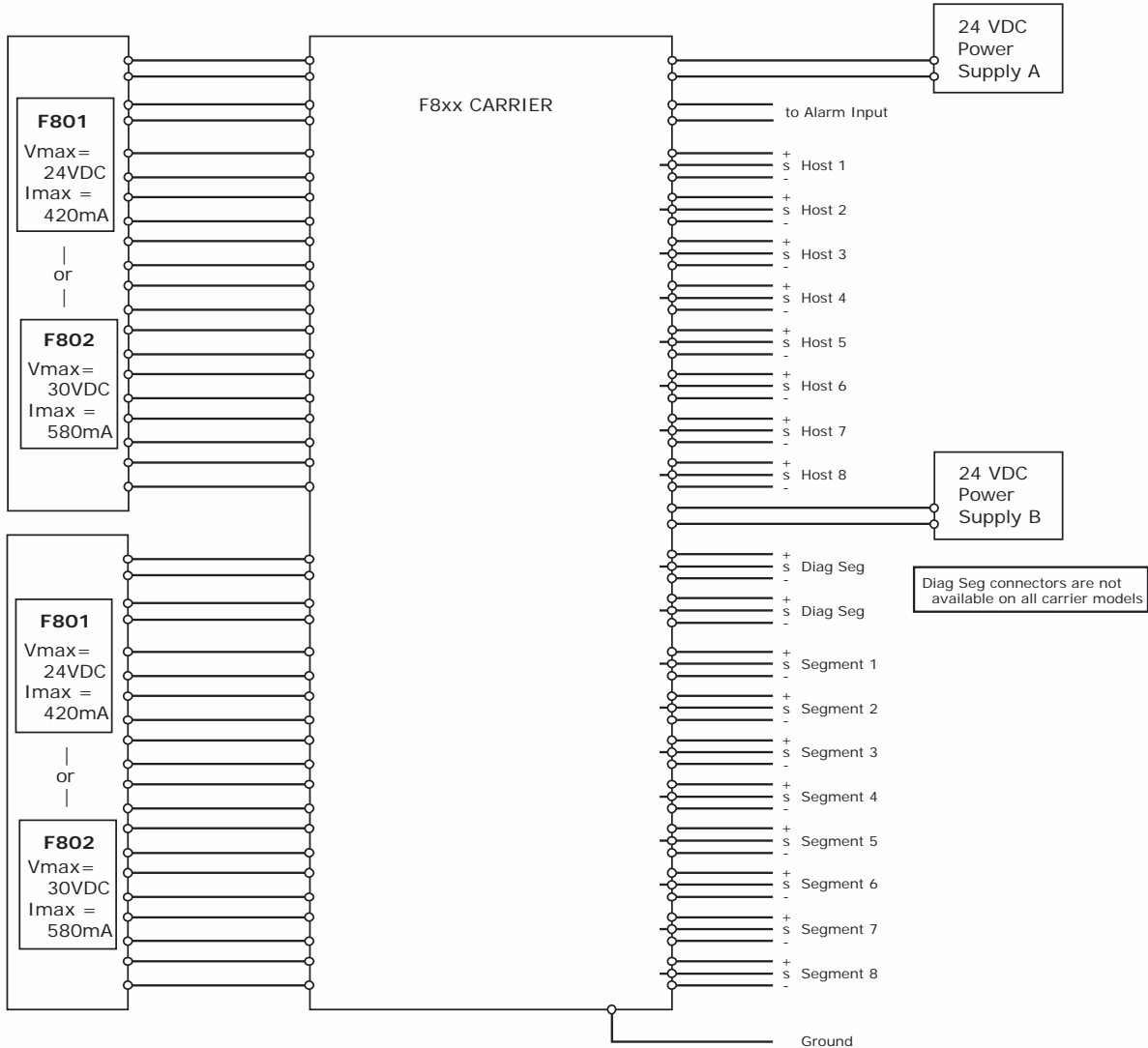

Fuse Power Supply Feed(s) per Carrier Requirements.

Carrier May Contain a Single F801 or F802 module where redundancy is not needed.

In such cases, only one Power Supply connection is needed. Also for the Alarm

Contact to work, an F800-BLK module must be installed in place of the missing F801 or F802 module.

The 24VDC Power Supplies may be installed in the Non-hazardous area.

Install F801 or F802 in conjunction with the Control Drawing for the Carrier Unit.

Do not mix an F801 and F802 on the same Carrier Unit.

Part Numbers: **F801, F802**

Installation must be in accordance with the National Electrical Code (NFPA 70, Article 504), ANSI/ISA-RP12.6, or the Canadian Electrical Code (CSA C22.1), as applicable.

WARNING: EXPLOSION HAZARD - DO NOT DISCONNECT EQUIPMENT UNLESS POWER HAS BEEN SWITCHED OFF OR THE AREA IS KNOWN TO BE NON-HAZARDOUS.



 <p>Relcom Inc. INDUSTRIAL LAN WIRING COMPONENTS AND TESTERS 2221 Yew Street, Forest Grove, Oregon 97116 USA</p>	
Title: CONTROL DRAWING FOR F801/F802 Class I, DIV 2 (ZONE 2) HAZARDOUS LOCATIONS	
Approved By: Mike Strauser	Date: 11-20-08
Drawing Number: 502-086	Rev.: C.0

HAZARDOUS (CLASSIFIED) LOCATION

Class I, Division 2, Groups A, B, C, D, T4
 Class I, Zone 2, IIC T4
 -40C ≤ Tamb ≤ 65C
 -40C ≤ Tamb ≤ 50C (F802 total load > 60% of rated maximum)
 To be installed in an IP54 or better enclosure

WARNING:
 EXPLOSION HAZARD - DO NOT DISCONNECT EQUIPMENT UNLESS POWER HAS BEEN SWITCHED OFF OR THE AREA IS KNOWN TO BE NON-HAZARDOUS.

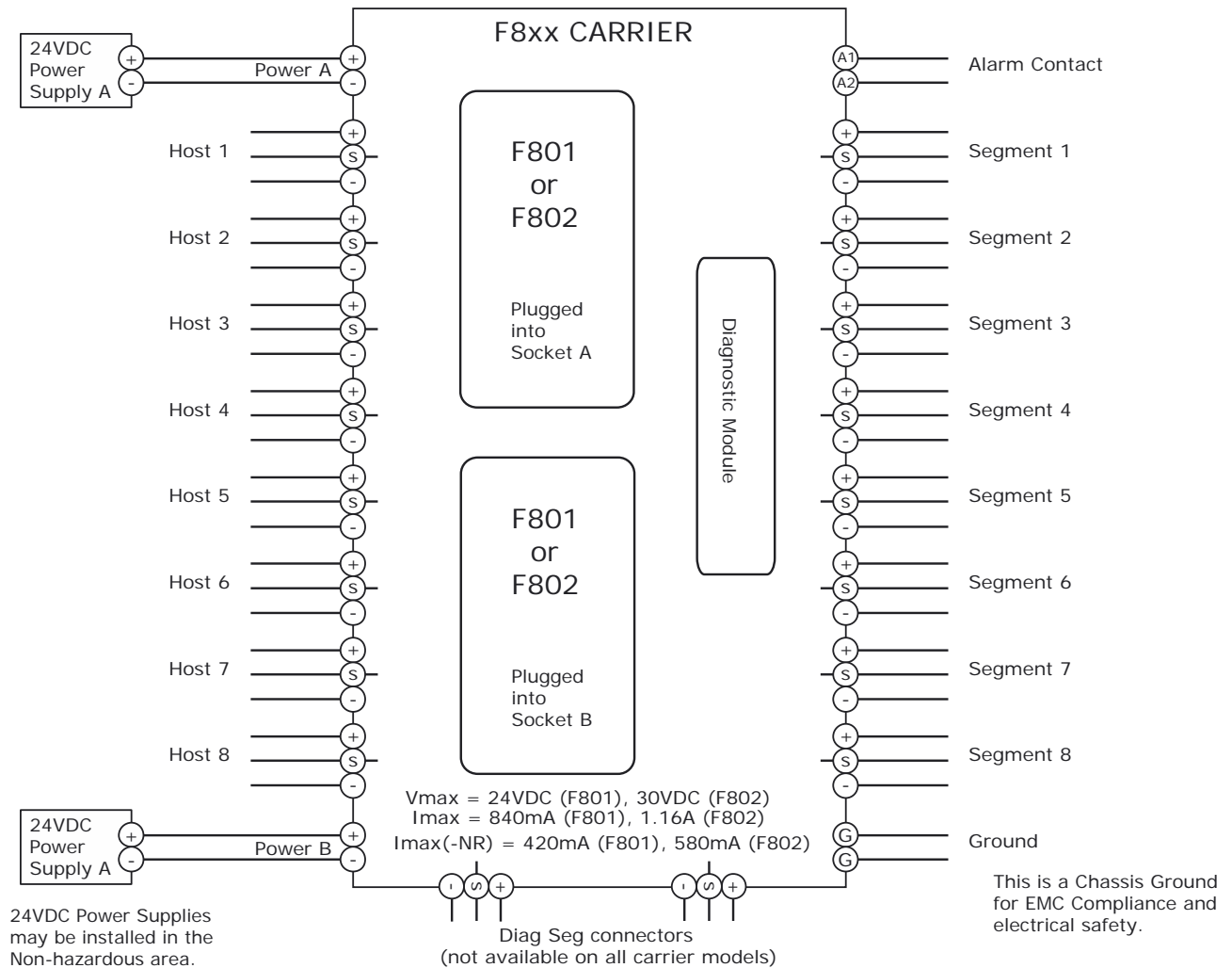

24VDC Power Supplies may be installed in the Non-hazardous area.

This drawing is representative of the F8xx series of Carriers. There will be minor differences in the various models.

Each of the 8 Segments (Hostx, Segmentx) are isolated from one another and from the Power Supplies. Host Terminals connect to the Host Control system which may be in a non-hazardous area.

Carrier May Contain a Single F801 or F802 module where redundancy is not needed ("-NR" option). In such cases, only one Power Supply connection is needed. Also for the Alarm Contact to work, an F800-BLK module must be installed in place of the missing F801 or F802 module.

Power Supplied to the Carrier must be fused for 8A circuitry.

Do not mix an F801 and F802 on the same Carrier.

Part Numbers:	Carriers	Kits w/ F801	Kits w/ F802
	F880-CA	F880-P*[-NR]	F880-2-P*[-NR]
	F880-CL	F880-L*[-NR]	F880-2-L*[-NR]
	F880-CR	F880-R*[-NR]	F880-2-R*[-NR]
	F890-CA	F890-P*[-NR]	F890-2-P*[-NR]
	F892-CA	F892-P*[-NR]	F892-2-P*[-NR]

Kits contain 1 or 2 F801 or F802 modules along with the Carrier and Pluggable Connectors. * = S for Pluggable Screw Terminal Connectors, C for Pluggable Cage Clamp Connectors.

Installation must be in accordance with the National Electrical Code (NFPA 70, Article 504), ANSI/ISA-RP12.6, or the Canadian Electrical Code (CSA C22.1), as applicable.



<p>Relcom Inc. <small>INDUSTRIAL LAN WIRING COMPONENTS AND TESTERS</small> 2221 Yew Street, Forest Grove, Oregon 97116 USA</p>	
Title: CONTROL DRAWING FOR F8xx Carriers CLASS I, DIV 2 (ZONE 2) HAZARDOUS LOCATIONS	
Approved By: Mike Strauser	Date: 11/20/08
Drawing Number: 502-087	Rev.: C.0

FM Special Conditions of Use

1. The F801/F802 Fieldbus Supply Modules and Carriers shall be installed in compliance with the enclosure, mounting, spacing and segregation requirements of the ultimate application, including a tool removable cover.
2. When installed in hazardous (classified) locations, a warning label must be prominently affixed near the unit(s) which warns that the cables or Fieldbus Supply Modules must not be removed or inserted unless the area is known to be non-hazardous.
3. It is the responsibility of the end user to provide adequate warning markings in French where required by local jurisdictions.

10 ATEX CATEGORY 3 INSTRUCTIONS

Safety instructions for installation and operating personnel

This manual contains basic safety instructions for installation, operation and maintenance and servicing. Failure to comply with these instructions can endanger personnel, the plant and the environment.

Before installation/commissioning:

- Read the operating instructions.
- Give adequate training to the installation and operating personnel.
- Ensure that the contents of the operating instructions are fully understood by responsible personnel.
- The national installation and mounting regulations (e.g. EN 60079-14, National Electrical Code) apply.

When operating the apparatus:

- Make the operating instructions available at the installation area (at all times).
- Observe safety instructions.
- Observe national safety and accident prevention regulations.
- Operate the equipment within its published specification.

Servicing/maintenance work or repairs which are not described in the operating instructions must not be performed without prior agreement with the manufacturer.

Any damage may render explosion protection null and void.

No changes to the devices or components impairing their explosion protection are permitted.

The device may only be fitted and used if it is in an undamaged, dry and clean state.