

MTL800 SERIES ENCLOSURES

SPECIFICATIONS

ENC8/ENC8SS: for
1 MTL831B transmitter, or
1 MTL838B receiver

ENC83/ENC83SS: for
1 MTL831B transmitter
(for use with 4-wire RTDs)

Location

Zone 0, 1 or 2

Protection

Dust-tight and waterproof to IEC529:IP67

Construction (ENC8 and ENC83)

Sheet steel, zinc sprayed and painted RAL7015 grey

Construction (ENC8SS and ENC83SS)

Stainless steel

Lid

Detachable with lift-off hinges, secured by captive fixing screws with a padlock hasp

Earth terminals

Fitted on internal earth rails; accommodate conductors up to 4mm²

Number of earth terminals

ENC8/ENC8SS: 22
ENC83/ENC83SS: 18

4-wire RTD terminals (ENC83/ENC83SS only)

32 ready-mounted terminals to accommodate conductors up to 4mm²

Gland fixing

Top and bottom gland plates detachable for drilling by user

Mounting

By fixed mounting lugs

Weight (excl. transmitters/receivers)

ENC8: 7kg
ENC83: 9.8kg

DIMENSIONS (MM)

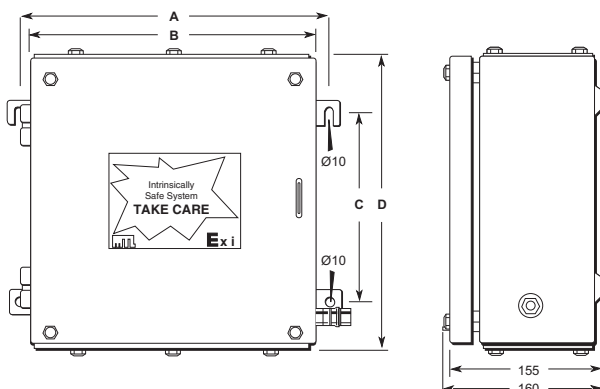

	A	B	C	D
ENC8	331	306	203	306
ENC83	407	380	305	466

MTL800 SERIES ACCESSORIES

SPECIFICATIONS

PCS83 software package (for MTL838B-MBF)

Function: Software configuration of multiplexer system
Format: 3.5 inch diskette
Requires: PC with DOS 2.2, or higher, and a serial (COM) port.

TO ORDER, SPECIFY:

Transmitters

MTL831B Analogue transmitter

Receivers

MTL838B-MBF Analogue receiver, RS485 and/or RS422 outputs for Modbus®

Analogue receiver accessories

PCS83 PC software configuration package

Process controller interface software

Contact MTL for details of software for interfacing with proprietary process controllers

Isolating interface units and earth leakage detectors

MTL3052 Digital isolator interface unit
MTL4220 Earth leakage detector

Enclosures

ENC8 General-purpose enclosure
ENC8SS General-purpose enclosure (stainless steel)
ENC83 Enclosure for MTL831B transmitter
ENC83SS Enclosure for MTL831B transmitter (stainless steel)

Literature

INM838B-MBF System protocol manual:
MTL838B-MBF Modbus® receivers
INM831B MTL831B manual
AN9010 Application Note: A user's guide to intrinsically safe input multiplexer systems
INS831B MTL831B mV Multiplexer transmitter
INS838B MTL838B-MBF Multiplexer receiver - Modbus® output

The given data is only intended as a product description and should not be regarded as a legal warranty of properties or guarantee. In the interest of further technical developments, we reserve the right to make design changes.



EUROPE (EMEA): +44 (0)1582 723633
enquiry@mtl-inst.com

THE AMERICAS: +1 800 835 7075
csinfo@mtl-inst.com

ASIA-PACIFIC: +65 6 487 7887
sales@mtlsing.com.sg

EPS830 RevF 170510