

MTL4545Y ISOLATING DRIVER

for 4–20mA HART® valve positioners
with line fault detection

The MTL4545Y accepts a 4/20mA floating signal from a safe-area controller to drive a current/pressure converter (or any other load up to 800Ω) in a hazardous area. For HART valve positioners, the module also permits bi-directional transmission of digital communication signals. Process controllers with a readback facility can detect open circuits in the field wiring: if these occur, the current taken into the terminals drops to a preset level.

SPECIFICATION

See also common specification

Number of channels

One

Location of I/P converter

Zone 0, IIC, T4–6 hazardous area if suitably certified
Div. 1, Group A, hazardous location

Working range

4 to 20mA

Digital signal bandwidth

500Hz to 10kHz

Maximum load resistance

800Ω (16V at 20mA)

Output resistance

> 1MΩ

Under/over range capability

Under range = 1mA
Over range = 24mA (load ≤ 520Ω)

Input and output circuit ripple

< 40μA peak-to-peak

Transfer accuracy at 20°C

Better than 20μA

Temperature drift

< 1.0μA/°C

Input characteristics

Field wiring state	
Normal	< 6.0V
Open-circuit	< 0.5mA
Short-circuit	N.A.



MTL4545Y

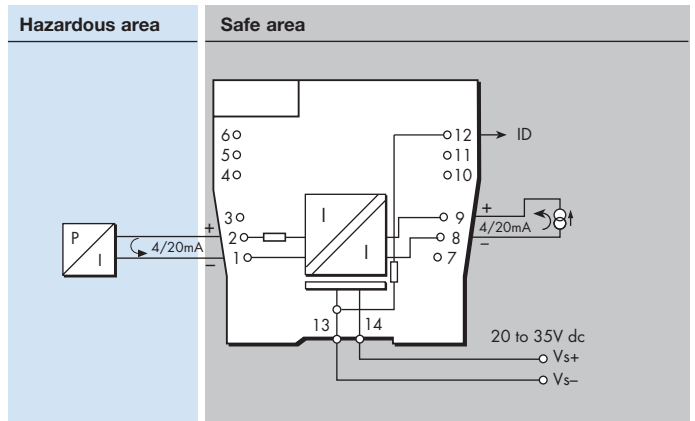

Response time

Settles within 200μA of final value within 100ms

Communications supported

HART

LED indicator

Green: power indication

Maximum current consumption (with 20mA signals into 250Ω load)

35mA at 24V dc

Power dissipation within unit (with 20mA signals into 250Ω load)

0.8W at 24V

Safety description

$U_o=28V$ $I_o=93mA$ $P_o=651mW$ $U_m=253V$ rms or dc

ID Resistor

43kΩ



SIL capable

These models have been assessed for use in IEC 61508 functional safety applications. SIL2 capable for a single device (HFT=0) SIL3 capable for multiple devices in safety redundant configurations (HFT=1) See data on MTL web site and refer to the safety manual.

The given data is only intended as a product description and should not be regarded as a legal warranty of properties or guarantee. In the interest of further technical developments, we reserve the right to make design changes.