

# MTL3058 AND MTL3059 SERIAL-DATA INTERFACES

**MTL3058 – RS232, general-purpose**

**MTL3059 – RS422, general-purpose**

These units enable two 'intelligent' devices mounted in safe areas to communicate, bidirectionally in serial data form, across a hazardous area. A typical application is the link between safe-area process control systems and multi-point or multi-stream analysers located in 'safe-area' instrument cabins or analyser houses in hazardous areas. Each unit is provided with a connector on the safe-area side for connecting RS232 (MTL3058) or RS422 (MTL3059) serial-data links. In all applications an interface unit is needed at each end of the cable, these being connected by three wires to provide full duplex communication. If the data flow is controlled by software (via Xon/Xoff), then one pair of units can be used for both 'transmit' and 'receive' data lines. If hardware handshaking is needed for data flow control (eg, CTS, RTS) then further pairs of units can be used.

## SPECIFICATION

See also 'Common specification'

### Number of channels

One two-way communication channel, fully floating

### Location of connecting cable

Zone 0, IIC, T4 hazardous area  
Div 1, Group A, hazardous location

### Safe-area signal

RS232, 300 to 19.2kbaud (MTL3058)  
RS422, 300 to 19.2kbaud (MTL3059)  
Via 4-terminal connector on side of unit

### Hazardous-area signal

Switched current 0 to 15mA at 6.8V

### Transmission distance (between isolators)

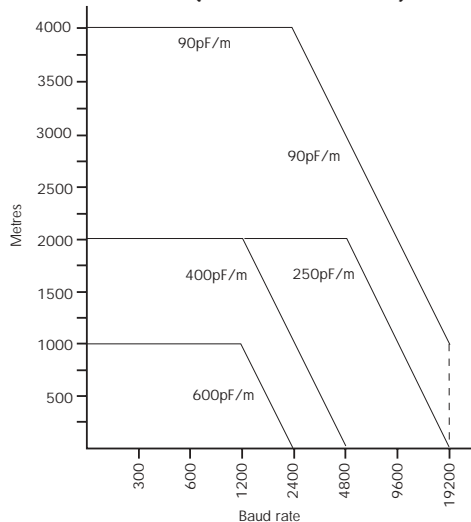

### Power requirement

62mA typical at 24V  
55mA at 35V to 70mA at 20V

### Power dissipation within unit

1.5W typical at 24V  
2.0W maximum at 35V

### Replaceable fuse

80mA, 5 x 20mm glass to DIN41571 sht.2, semi-time-lag (M)

### Safety description

#### Terminals 5 & 6 wrt 7 & 8

15V, 194Ω, 77mA,  $U_m = 250V$  rms or dc

### FM max entity parameters

$V_{oc} = 15V$ ,  $I_{sc} = 154mA$ ,  $C_a = 0.11\mu F$ ,  $L_a = 1.55mH$

### Weight

170g

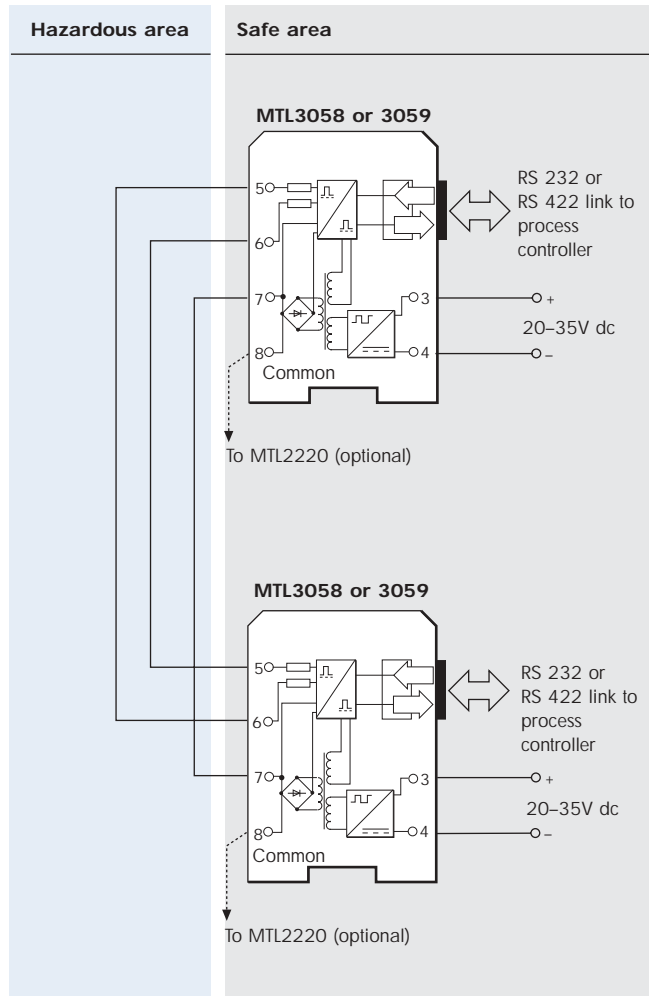

## OTHER APPLICATIONS

Since both the MTL3058 and MTL3059 convert the safe-area signal into a common hazardous-area format, it is possible to convert between RS232 and RS422 by using one MTL3058 and one MTL3059.

