

MTL F809F-Plus

FOUNDATION™ fieldbus diagnostics module



DECLARATION OF CONFORMITY

A printed version of the Declaration of Conformity has been provided separately within the original shipment of goods. However, you can find a copy of the latest version at -

<http://www.mtl-inst.com/certificates>

CONTENTS

DECLARATION OF CONFORMITY	ii
GENERAL INFORMATION	iv - v
1 OVERVIEW	1
1.1 Components and accessories	1
2 INSTALLATION	2
2.1 Mounting	2
2.2 Power requirements	3
2.3 Configuration of fieldbus communication segment	3
2.4 Installation for communication on separate fieldbus segment	4
2.4.1 Interconnection via carrier	4
2.4.2 Interconnection via top connector	5
2.4.3 Fieldbus segment design rules	6
2.4.4 Diagnostics module power supply	6
2.4.5 Diagnostics module segment termination	6
2.5 Ground Reference Switches	6
3 CONFIGURATION	7
3.1 Standard	7
3.2 F809F-Plus Configuration	7
4 BLOCK CONFIGURATION	8
4.1 Resource Block	8-10
4.1.1 Diagnostic Bits	10-11
4.1.2 Block errors	11
4.1.3 Modes	11
4.2 Transducer Blocks	12
4.2.1 Transducer Block Errors	12
4.2.2 Transducer Block Modes	12
4.2.3 Transducer Block Alarm Detection	13
4.2.4 System Transducer Block (SysTB)	13-15
4.2.4.1 System alarms	16
4.2.4.2 Self test alarms	16
4.2.4.3 Methods	17
4.2.5 Segment Transducer Block (SegTB)	17-20
4.2.5.1 SEGMENT_ALARMS - Descriptions and Corrective Actions	21-22
4.2.5.2 DEVICE_ALARMS - Descriptions and Corrective Actions	22
4.2.5.3 DEVICE_ALERTS - Descriptions	22
4.3 Discrete Input Block	23
4.3.1 Discrete Input Block Errors	23
5 OPERATION AND MAINTENANCE	24
5.1 LED indicators	24
5.2 FOUNDATION™ fieldbus Information	24
5.2.1 Commissioning (Addressing)	24
5.3 Hardware Maintenance	24
5.3.1 Communication/Power Check	24
5.3.2 Resetting the Configuration (RESTART)	24
5.4 Troubleshooting	25
5.4.1 FOUNDATION™ fieldbus	25
5.4.2 Resource Block	25
5.4.3 System and Segment Transducer Block Troubleshooting	25
APPENDIX A: Troubleshooting Table	26-27

GENERAL INFORMATION

NOTE

This manual applies to Diagnostic Module F809F-Plus version MT03. The version number is indicated on the module's side label.

For F809F versions MT01 and MT02, refer to instruction manuals INM F809F-1 or INM F809F-2C, which are available to download from the MTL website.

Safety instructions for installation and operating personnel

These operating instructions contain basic safety instructions for installation, operation and maintenance and servicing. Failure to comply with these instructions can endanger personnel, the plant and the environment.

Before installation/commissioning:

- Read the operating instructions.
- Give adequate training to the installation and operating personnel.
- Ensure that the contents of the operating instructions are fully understood by responsible personnel.
- The national installation and mounting regulations (e.g. EN 60079-14) apply.

When operating the devices:

- Make the operating instructions available at the installation area (at all times).
- Observe safety instructions.
- Observe national safety and accident prevention regulations.
- Operate the equipment within its published specification.
- Servicing/maintenance work or repairs which are not described in the operating instructions must not be performed without prior agreement with the manufacturer.
- Any damage may render hazardous-area protection null and void.
- No changes to the devices or components impairing their hazardous-area protection are permitted.
- The device may only be fitted and used if it is in an undamaged, dry and clean state.

If there are any points that remain unclear:

- Contact your local Eaton Office
- Product and contact details are also available from the company website: <http://www.mtl-inst.com>

Consignes de sécurité pour le personnel d'installation et le personnel d'exploitation

Ces consignes d'exploitation renferment les consignes de sécurité de base pour l'installation, l'exploitation la maintenance et les services. Ne pas se conformer à ces consignes peut mettre en danger le personnel, l'usine et l'environnement.

Avant l'installation et la première mise en service :

- Lire les consignes d'exploitation
- Fournir la formation appropriée aux personnels d'installation, et d'exploitation
- S'assurer que le contenu des consignes d'exploitation est pleinement assimilé par le personnel responsable
- Appliquer les règlements nationaux en vigueur pour l'installation et le montage (par ex. NE 60079-14)

Au cours de l'exploitation des appareils:

- Faire en sorte que les consignes d'exploitation soient à disposition sur la zone d'installation (à tous moments)
- Observe safety instructions.
- Observer les consignes de sécurité.
- Observer les règlements nationaux de sécurité et de prévention des accidents
- Exploiter l'équipement dans les limites de sa spécification publiée
- Les travaux de service/maintenance ou les réparations non décrits dans les consignes ne doivent pas être exécutés sans l'agrément préalable du fabricant.
- Tout endommagement peut rendre caduque la protection en zone dangereuse
- Aucune modification apportée à l'appareil ou aux composants, portant atteinte à leur protection en zone dangereuse, ne sera autorisée
- L'appareil ne peut être utilisé que s'il se trouve dans un état non endommagé, sec et propre.

S'il reste quelques points à éclaircir :

- Contactez votre bureau Eaton local
- Les détails sur les produits et les contacts sont également disponibles à partir du site de la compagnie <http://www.mtl-inst.com>

<p>NOTE</p> <p>The F809F-Plus should only be fitted to a carrier whose low voltage DC power is derived from a power supply compliant with EN61010 or EN60950 double or reinforced insulation.</p> <p>The F809F-Plus has an extended operating temperature range. Cabling connected to it should be rated in accordance with maximum and minimum ambient temperatures expected</p>
--

FOR US AND CANADA:

THIS EQUIPMENT IS SUITABLE FOR USE IN CLASS1, DIVISION 2, GROUPS A, B, C, D AND CLASS 1, ZONE 2, GROUP IIC OR NON-HAZARDOUS LOCATIONS ONLY.

	WARNING/AVERTISSEMENT
	EXPLOSION HAZARD - SUBSTITUTION OF COMPONENTS MAY IMPAIR SUITABILITY FOR CLASS 1, DIVISION 2. RISQUE D'EXPLOSION - LA SUBSTITUTION DE COMPOSANTS PEUT RENDRE CE MATERIEL INACCEPTABLE POUR LES EMPLACEMENTS DE CLASS 1, DIVISION2

	WARNING/AVERTISSEMENT
	EXPLOSION HAZARD - DO NOT DISCONNECT EQUIPMENT UNLESS POWER HAS BEEN SWITCHED OFF OR THE AREA IS KNOWN TO BE NON-HAZARDOUS RISQUE D'EXPLOSION - AVANT DE DECONNECTER L'EQUIPEMENT, COUPER LE COURANT OU S'ASSURER QUE L'EMPLACEMENT EST DESIGNE NON DANGEREUX.

this page is left intentionally blank

MTL F809F-Plus Diagnostics module



1 OVERVIEW

The F809F-Plus Fieldbus Diagnostic Module is available as an option for use with 918x Series, F800 Series and some F600 Series fieldbus power supplies. It plugs into a 918x, F8xx or F6x8 Series power supply carrier, or an F8x8 diagnostic module carrier and monitors the performance of each of the eight fieldbus segments, providing information on the network health and capturing retransmissions between the fieldbus devices and control system.

The parameters measured include the bulk power supply input voltage, temperature, segment voltages and signal levels of all devices. Average and peak noise are measured in each of three frequency bands. Additionally the monitor checks for correct bus termination and for short-circuits between the fieldbus signal wires and cable shields. Retransmissions are also measured. The measured physical layer parameters are used to predict the corrective action required. This allows problems to be rectified before poor network health results in devices being removed from the 'live list', which could affect the operation of the plant. Measurements may alternatively be captured and sent to off-site experts for interpretation.

The F809F-Plus is a FOUNDATION™ fieldbus device, and communicates with the host control system via a fieldbus segment. This allows the network status and measured parameters to be displayed in the instrument management software on the host control system.

1.1 Components and accessories

This manual is designed to assist in the installation, configuration and maintenance of the F809F-Plus Fieldbus Diagnostic Module version MT03 (see side label), as explained on the opposite page under General Information.

For product specification see the EPS F809F-Plus data sheet.

Features of this version include:

- Superior immunity to noise on the 'communicating' segment – continues to report diagnostic information in electrically noisy environments.
- Enhanced short-to-shield detection, including wider choice of ground reference options and immunity to interference from mains-connected Emerson 375 and 475 communicators.
- Extended measurement range for fieldbus power supply voltage – compatible with full range of MTL power supply types.
- Registered to Fieldbus Foundation ITK 6.0, including field diagnostic bits according to NAMUR NE107 recommendations.
- Support for fully updated eEDDL and DTM user interfaces.

2 INSTALLATION

The F809F-Plus is designed for carrier mounting and may be mounted on any 918x, MTL F8xx or F6x8 series carrier. See the MTL 918x, F8xx or F6x8 series power supply or F8x8 carrier installation manual for details of how these carriers are installed.

The F809F-Plus Fieldbus Diagnostic Monitor receives redundant power feeds and connections to the eight monitored fieldbus segments via the carrier. The diagnostic information is conveyed to the controlling host via a fieldbus segment and the user has the choice of segment 1 or 8 (of the segments being monitored), or a totally separate segment of their choosing. The segment chosen for communication is configured using a plugin connector located on the front edge of the module.

2.1 Mounting

Align the F809F-Plus module with the two multi-pin connectors* on the carrier and hold it in place while tightening the two captive fixing screws.

NOTE

The fixing screws should be tightened to a minimum torque value of 1.2Nm, but should not exceed a torque value of 1.5Nm.

To remove the F809F-Plus, support the module while unscrewing the two fixing screws at its base. Lift the module off the carrier connector.



Figure 2.1: Unused connector

* A third connector is provided on the module for factory testing and firmware upgrade. This connector, the largest of the three, is not used on the carrier and is identified on the F809F-Plus side label. See Figure 2.1.

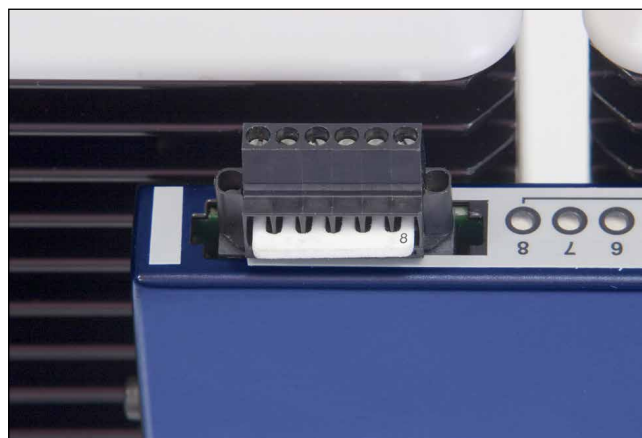

Figure 2.2: Configuration "comb"

2.2 Power requirements

An F809F-Plus module draws approximately 15mA from the communicating fieldbus segment. This needs to be included when calculating the total design current requirement for that segment.

2.3 Configuration of fieldbus communication segment

The communications segment that will be used is determined by configuring the connector on the front face of the module. A 6-pin “comb”, supplied with the module, is used to define the communication segment by inserting it one of two ways into the connector (see Figure 2-2), or omitting it altogether.

The F809F-Plus is supplied pre-configured to communicate on segment 8 (eight) of the monitored fieldbus segments.

The communication segment can be changed “in the field” by a simple change to the connector on the front face.



Figure 2.3: Removing protective cap

1. Remove the protective cap from the top of the fieldbus module by squeezing the ends. See Figure 2-3.
2. Loosen the six screws in the connector.
3. Remove the “comb” from the connector.
4. (a) **For communication on segment 8 (as supplied)**
Place the “comb” in the connector, as shown (Figure 2-2), so that the number “8” is visible on the top (right) surface.
- (b) **For communication on segment 1**
Place the “comb” in the connector so that the number “1” is visible on top (right) surface.
- (c) **For communication on a separate segment**
No comb is required.
5. If the comb is being used, tighten the six screws to retain it.
6. Replace the protective cap.

2.4 Installation for communication on separate fieldbus segment

If a separate fieldbus segment is the chosen option, then it can communicate the diagnostic data via the top connector on the F809F-Plus or, in some cases, through dedicated connectors on the carrier. The table below shows which carriers (by batch code) provide this option.

Carrier type	Diagnostic data connection options	
	via carrier	via top connector
F618D-CL	All	All
F860-CA	None	All
F880-CR-xx	None	All
F880-CL-xx	None	All
F880-CA-xx	0727 or later	All
F888-CA-xx	All	All
F890-CA-xx	0727 or later	All
F892-CA-xx	0727 or later	All
F898-CA-xx	All	All
918x-CA-Px	All	All

2.4.1 Interconnection via carrier

Figure 2-4 shows how a dedicated diagnostic segment, comprising multiple F6x8, F8xx or 918x carriers, is interlinked, powered and terminated. Where carriers are installed in vertical columns, connect the H1+, H1- and S terminals of adjacent carriers as shown.

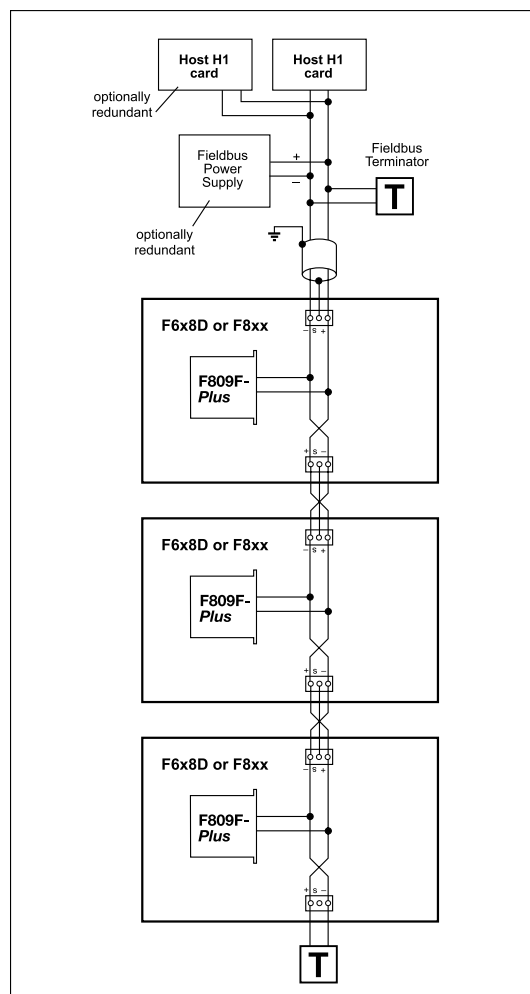

Figure 2.4: Carrier linking

2.4.2 Interconnection via top connector

Figure 2-5 shows how a dedicated diagnostic segment comprising multiple F8xx carriers is interlinked and terminated.

The fieldbus spur is connected to the two middle terminals in the top connector - see Figures 2-2 and 2-6.

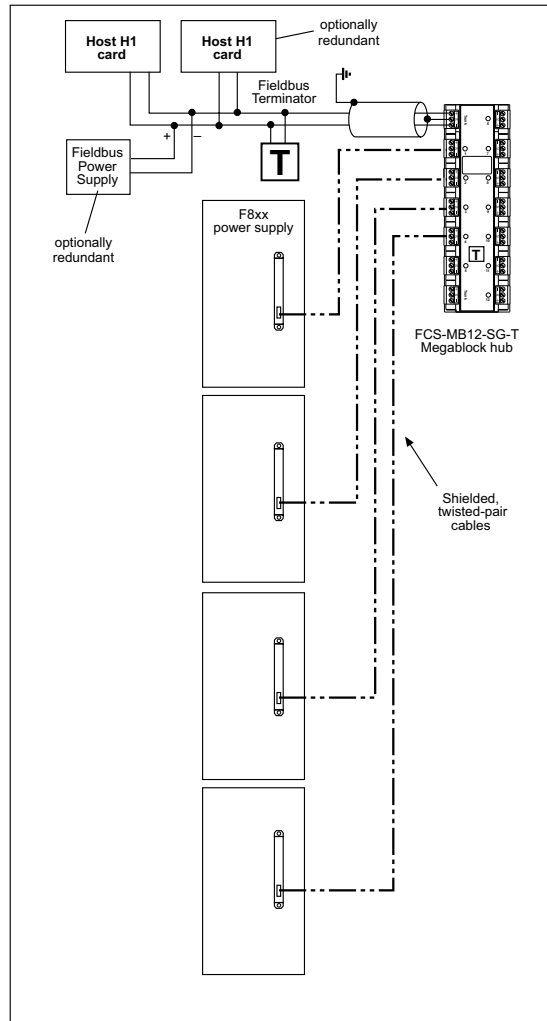

Figure 2.5: Module connector linking



Figure 2.6: Connector wiring

2.4.3 Fieldbus segment design rules

A segment may support a number of F809F-Plus modules. The actual number is based on a number of factors:

- the logical device limit of the host,
- the fieldbus power supply capacity,
- operational constraints such as bandwidth
- the overall impact on the system if that diagnostic segment should be lost.

Shielded, twisted-pair cable, complying with FOUNDATION™ fieldbus 'Type A' construction is recommended for the diagnostic segment. Unshielded instrument cable is suitable for short interconnections between adjacent carriers.

2.4.4 Diagnostics module power supply

The diagnostic segment must be powered by a conditioned fieldbus power supply (see Figure 2-4 & 2-5) that will provide a voltage in the range 9–32V DC at each F809F-Plus fieldbus diagnostic module. This power supply may be either simplex or redundant, depending on the application, and be capable of providing sufficient current for the entire diagnostic segment.

Each F809F-Plus module draws approximately 15mA, so a segment comprising 10 F809F-Plus modules, for example, will require an output current of at least 150mA. Suitable multi-segment redundant fieldbus power supplies include MTL 918x-x1 and F8x0. Type FPS-I may be selected where a single-segment redundant power supply is preferred. Alternatively, if a non-redundant power supply is acceptable, suitable types include F101, F102 and FPS-DT.

2.4.5 Diagnostics module segment termination

As with all Fieldbus segments, the one used for the diagnostic data must be terminated at both ends to maintain the bus impedance within FOUNDATION™ fieldbus limits. When interconnections are via the carrier, a terminator must be connected between the H1+ and H1- terminals of the diagnostic bus connector at the far end of the segment (see Figure 2-4). Suitable terminators for this are MTL type FBT1-IS or F100.

When F809F-Plus modules are interconnected by means of the top connector, it is preferable to connect each module to the spur of a Megablock device coupler. This protects the diagnostic segment against a short-circuit on any spur. A Megablock with a built-in terminator should be selected. Termination of the bus at the host end may be provided either by an integrated terminator within the power supply or by means of a separate terminator.

2.5 Ground Reference Switches

Switches are provided on the side of the F809F-Plus module to select different grounding options - see Figure 2.7. The switch positions are chosen according to the type of MTL Fieldbus Power Supply with which the F809F-Plus is being used, as described in the following table:

Switch A position	Switch B position	Fieldbus power supply type
0	0	Invalid configuration - do not select
0	1	All F8xx Series except F860
1	0	F618D
1	1	All 918x Series and F860

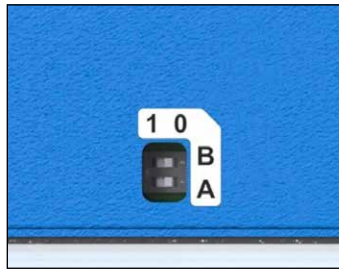

Figure 2.7: Ground reference switches



Figure 2.8: Case ground terminal

A separate case ground terminal is provided (Figure 2-8) to enable the case of the module to be linked to a ground terminal on the circuit board.

3 CONFIGURATION

3.1 Standard

Each FOUNDATION™ fieldbus configuration tool or host system has a different way of displaying and performing configurations. Some will use Device Descriptions (DDs) and DD Methods to make configuration and displaying of data consistent across host platforms.

Refer to the fieldbus control system's documentation to perform configuration changes using a FOUNDATION™ fieldbus host or configuration tool.

The function of the F809F-Plus is to provide diagnostic data, therefore configuration changes can be made with the MODE_BLK.ACTUAL in AUTO, MANUAL or Out Of Service (OOS) mode.

NOTE

Fieldbus devices used in process applications usually have to be set to OOS mode before making configuration changes.

3.2 F809F-Plus Configuration

The F809F-Plus is available with the standard configuration setting. The configuration settings and block configuration may be changed in the field with the FOUNDATION™ fieldbus host or a configuration tool.

4 BLOCK CONFIGURATION

4.1 Resource Block

The resource block defines the physical resources of the device including type of measurement, memory, etc. The resource block also defines functionality, such as shed times, that is common across multiple blocks. The block has no linkable inputs or outputs and it performs memory-level diagnostics.

Table 4.1: Resource block parameters

Number	Parameter	Description
00	BLOCK	
01	ST_REV	The revision level of the static data associated with the function block.
02	TAG_DESC	
03	STRATEGY	The strategy field can be used to identify grouping of blocks.
04	ALERT_KEY	The identification number of the plant unit.
05	MODE_BLK	The ACTUAL, TARGET, PERMITTED, and NORMAL modes of the block. For further description, see the Mode parameter formal model in FF-890.
06	BLOCK_ERR	This parameter reflects the error status associated with the hardware or software components associated with a block. Multiple errors may be shown. For a list of enumeration values, see FF-890, Block_Err formal model.
07	RS_STATE	State of the function block application state machine. For a list of enumeration values, see FF-890.
08	TEST_RW	Read/write test parameter - used only for conformance testing.
09	DD_RESOURCE	String identifying the tag of the resource which contains the Device Description for the resource.
10	MANUFAC_ID	Manufacturer identification number - used by an interface device to locate the DD file for the resource.
11	DEV_TYPE	Manufacturer's model number associated with the resource - used by interface devices to locate the DD file for the resource.
12	DEV_REV	Manufacturer revision number associated with the resource - used by an interface device to locate the DD file for the resource.
13	DD_REV	Revision of the DD associated with the resource - used by the interface device to locate the DD file for the resource.
14	GRANT_DENY	Options for controlling access of host computer and local control panels to operating, tuning and alarm parameters of the block.
15	HARD_TYPES	The types of hardware available as channel numbers. The supported hardware type is: SCALAR_INPUT
16	RESTART	Allows a manual restart to be initiated. See also Section 5.4.2
17	FEATURES	Used to show supported resource block options. The supported features are: SOFT_WRITE_LOCK_SUPPORT and REPORTS.
18	FEATURE_SEL	Used to select resource block options.
19	CYCLE_TYPE	Identifies the block execution methods available for this resource. The supported cycle types are: SCHEDULED, and COMPLETION_OF_BLOCK_EXECUTION.
20	CYCLE_SEL	Used to select the block execution method for this resource.
21	MIN_CYCLE_T	Time duration of the shortest cycle interval of which the resource is capable.
22	MEMORY_SIZE	Available configuration memory in the empty resource. To be checked before attempting a download.
23	NV_CYCLE_T	Minimum time interval specified by the manufacturer for writing copies of NV parameters to non-volatile memory. Zero means it will never be automatically copied. At the end of NV_CYCLE_T, only those parameters which have changed need to be updated in NVRAM.
24	FREE_SPACE	Percent of memory available for further configuration. Zero in preconfigured resource.
25	FREE_TIME	Percent of the block processing time that is free to process additional blocks.
26	SHED_RCAS	Time duration at which to give up on computer writes to function block RCas locations. Shed from RCAs will never happen when SHED_RCAS = 0.
27	SHED_ROUT	Time duration at which to give up on computer writes to function block ROut locations. Shed from ROut will never happen when SHED_ROUT = 0.
28	FAULT_STATE	Condition set by loss of communication to an output block, fault promoted to an output block or physical contact. When faultstate condition is set, then output function blocks will perform their FSTATE actions.

continued

29	SET_FSTATE	Allows the FAIL_SAFE condition to be manually initiated by selecting Set.
30	CLR_FSTATE	Writing a Clear to this parameter will clear the device FAIL_SAFE if the field condition has cleared.
31	MAX_NOTIFY	Maximum number of unconfirmed notify messages possible.
32	LIM_NOTIFY	Maximum number of unconfirmed alert notify messages allowed.
33	CONFIRM_TIME	The time the resource will wait for confirmation of receipt of a report before trying again. Retry will not happen when CONFIRM_TIME=0.
34	WRITE_LOCK	If set, all writes to static and non-volatile parameters are prohibited, except to clear WRITE_LOCK. Block inputs will continue to be updated.
35	UPDATE_EVT	This alert is generated by any change to the static data.
36	BLOCK_ALM	The BLOCK_ALM is used for all configuration, hardware, connection failure or system problems in the block. The cause of the alert is entered in the subcode field. The first alert to become active will set the Active status in the Status attribute. As soon as the Unreported status is cleared by the alert reporting task, another block alert may be reported without clearing the Active status, if the subcode has changed.
37	ALARM_SUM	The current alert status, unacknowledged states, unreported states, and disabled states of the alarms associated with the function block.
38	ACK_OPTION	Selection of whether alarms oscillated with the block will be automatically acknowledged.
39	WRITE_PRI	Priority of the alarm generated by clearing the write lock.
40	WRITE_ALM	This alert is generated if the write lock parameter is cleared.
41	ITK_VER	Major revision number of the interoperability test case used in certifying this device as interoperable. The format and range are controlled by the Fieldbus FOUNDATION™.
42	FD_VER	The major version of the Field Diagnostics specification used for the development of this device.
43	FD_FAIL_ACTIVE	This parameter reflects the error conditions that are being detected as active as selected for the 'Failed' category. It is a bit string, so that multiple conditions may be shown.
44	FD_OFFSPEC_ACTIVE	This parameter reflects the error conditions that are being detected as active as selected for the 'Off Specification' category. It is a bit string, so that multiple conditions may be shown.
45	FD_MAINT_ACTIVE	This parameter reflects the error conditions that are being detected as active as selected for the 'Maintenance' category. It is a bit string, so that multiple conditions may be shown.
46	FD_CHECK_ACTIVE	This parameter reflects the error conditions that are being detected as active as selected for the 'Check Function' category. It is a bit string, so that multiple conditions may be shown.
47	FD_FAIL_MAP	This parameter enables or disables conditions to be detected as active for the 'Failed' category
48	FD_OFFSPEC_MAP	This parameter enables or disables conditions to be detected as active for the 'Off Specification' category
49	FD_MAINT_MAP	This parameter enables or disables conditions to be detected as active for the 'Maintenance' category
50	FD_CHECK_MAP	This parameter enables or disables conditions to be detected as active for the 'Check Function' category
51	FD_FAIL_MASK	This parameter is used to suppress any single or multiple conditions that are active, in the 'Failed' category, from being broadcasted through the Alarm parameter.
52	FD_OFFSPEC_MASK	This parameter is used to suppress any single or multiple conditions that are active, in the 'Off Specification' category, from being broadcasted through the Alarm parameter.
53	FD_MAINT_MASK	This parameter is used to suppress any single or multiple conditions that are active, in the 'Maintenance' category, from being broadcasted through the Alarm parameter.
54	FD_CHECK_MASK	This parameter is used to suppress any single or multiple conditions that are active, in the 'Check Function' category, from being broadcasted through the Alarm parameter.
55	FD_FAIL_ALM	This parameter is used to broadcast a change of an unmasked 'Failed' condition.
56	FD_OFFSPEC_ALM	This parameter is used to broadcast a change of an unmasked 'Off Specification' condition.
57	FD_MAINT_ALM	This parameter is used to broadcast a change of an unmasked 'Maintenance' condition.
58	FD_CHECK_ALM	This parameter is used to broadcast a change of an unmasked 'Check Function' condition.
59	FD_FAIL_PRI	This parameter allows the user to specify the priority of the 'Failed' Alarm category.
60	FD_OFFSPEC_PRI	This parameter allows the user to specify the priority of the 'Off Specification' Alarm category.
61	FD_MAINT_PRI	This parameter allows the user to specify the priority of the 'Maintenance' Alarm category.
62	FD_CHECK_PRI	This parameter allows the user to specify the priority of the 'Check Function' Alarm category.

continued

63	FD_SIMULATE	When simulation is enabled the Field Diagnostics conditions are taken from 'Diagnostic Simulate Value' otherwise the conditions are taken from 'Diagnostic Value'.
64	FD_RECOMMEN_ACT	This parameter is a device enumerated summarization of the most severe condition or conditions detected. The DD should describe by enumerated action, what should be done to alleviate the condition or conditions.
65	IDENTIFICATION_MEASUREMENT (PRODUCT_ID, SERIAL_NUMBER, HW_REVISION, SOFTWARE_VERSION, FIRMWARE_CRC)	Measurement product ID, serial number, hardware revision and software version. View as hexadecimal number.
66	IDENTIFICATION_FIELDBUS (SERIAL_NUMBER, HW_REVISION, SOFTWARE_VERSION, FIRMWARE_CRC)	Fieldbus serial number, hardware revision and software version. View as hexadecimal number.

4.1.1 Diagnostic Bits

Diagnostic bits permit the aggregation of all device status and diagnostics so that a Host system can integrate this information into its infrastructure.

Four alarm categories as defined by the NAMUR NE-107 specification, Failed, Off-Specification, Maintenance and Check function share 11 conditions.

The mapping of these conditions is as follows:

Diagnostic Bit	Condition	Description
0	CHECK (Fieldbus Foundation defined condition)	Set if any transducer block has a normal mode other than OOS and the Actual is not Auto
1	"Device Needs Maintenance Soon" bit of the BLOCK_ERR parameter within segment 1 transducer block.	Set if any Segment / Device alarm bits are set within segment 1
2	"Device Needs Maintenance Soon" bit of the BLOCK_ERR parameter within segment 2 transducer block.	Set if any Segment / Device alarm bits are set within segment 2
3	"Device Needs Maintenance Soon" bit of the BLOCK_ERR parameter within segment 3 transducer block.	Set if any Segment / Device alarm bits are set within segment 3
4	"Device Needs Maintenance Soon" bit of the BLOCK_ERR parameter within segment 4 transducer block.	Set if any Segment / Device alarm bits are set within segment 4
5	"Device Needs Maintenance Soon" bit of the BLOCK_ERR parameter within segment 5 transducer block.	Set if any Segment / Device alarm bits are set within segment 5
6	"Device Needs Maintenance Soon" bit of the BLOCK_ERR parameter within segment 6 transducer block.	Set if any Segment / Device alarm bits are set within segment 6
7	"Device Needs Maintenance Soon" bit of the BLOCK_ERR parameter within segment 7 transducer block.	Set if any Segment / Device alarm bits are set within segment 7

continued

8	"Device Needs Maintenance Soon" bit of the BLOCK_ERR parameter within segment 8 transducer block.	Set if any Segment / Device alarm bits are set within segment 8
9	"Device Needs Maintenance Soon" bit of the BLOCK_ERR parameter for the system transducer block.	Set if any System Alarm and Self-test fault alarms are set
10	Logical OR of the "Device Needs Maintenance Soon" bits of all 9 transducer blocks	Set if any System, Segment, Device or Self-test alarms are set

4.1.2 Block errors

Table 4-2 lists all conditions in the BLOCK_ERR parameter, with conditions in bold supported by the F809F-Plus.

Table 4.2: BLOCK_ERR conditions

Number	Name and Description
0	Other
1	Block Configuration Error
2	Link Configuration Error
3	Simulate Active
4	Local Override
5	Device Fault State Set
6	Device Needs Maintenance Soon
7	Input failure/process variable has bad status
8	Output Failure
9	Memory Failure
10	Lost Static Data: Static data that is stored in non-volatile memory has been lost.
11	Lost NV Data
12	Readback Check Failed
13	Device Needs Maintenance Now
14	Power Up: The device was just powered-up.
15	OOS: The actual mode is out of service.

4.1.3 Modes

The resource block supports two modes of operation as defined by the MODE_BLK parameter:

Automatic (Auto)

The block is processing its normal background memory checks. In this mode, changes can be made to all configurable parameters.

Out of Service (OOS)

The block is not processing its tasks. The BLOCK_ERR parameter shows Out of Service. In this mode, changes can be made to any configurable parameters. The target mode of a block may be restricted to one or more of the supported modes.

4.2 Transducer Blocks

There are two types of transducer blocks that allow the user to view and manage the channel information. These blocks are:

- System Transducer Block (SysTB) – see “System Transducer Block (SysTB)” in Section 4.2.4.
- Segment Transducer Block (SegTB), one for each of the eight segments – see “Segment Transducer Block (SegTB)” in Section 4.2.5.

These Transducer blocks contain specific diagnostic data.

4.2.1 Transducer Block Errors

The following conditions are reported in the BLOCK_ERR parameters. Conditions in bold are supported in the transducer blocks.

Table 4.3: Block/Transducer error

BLOCK_ERR

Number	Name and Description
0	Other
1	Block configuration error
2	Link configuration error
3	Simulate active
4	Local override
5	Device fault state set
6	Device needs maintenance soon
7	Input failure
8	Output failure
9	Memory failure
10	Lost static data
11	Lost NV data
12	Readback check failed
13	Device needs maintenance now
14	Power up: The device was just powered up
15	Out of service: The actual mode is out of service

4.2.2 Transducer Block Modes

The transducer block supports three modes of operation:

Automatic (Auto)

The block outputs reflect the diagnostic measurement board inputs. In this mode, changes can be made to all configurable parameters.

Out of Service (OOS)

The block is not processed. Channel outputs are not updated and the status is set to Bad: Out of Service for each channel. The BLOCK_ERR parameter shows Out of Service.

In this mode, changes can be made to any configurable parameters. The target mode of a block may be restricted to one or more of the supported modes.

Manual Mode

All Transducer blocks move into this mode if the Resource Block is in OOS mode.

The block outputs reflect the diagnostic measurement board inputs. In this mode changes can be made to all configurable parameters.

4.2.3 Transducer Block Alarm Detection

If any alarm (except the new and removed device alerts) is set within the Transducer Block then the Needs Maintenance Soon Bit is set in the BLOCK_ERR parameter. The regular monitoring by the control system of the BLOCK_ERR parameter can be used to inform the right person of the alarm condition. Typically this will be the instrument technician responsible for fieldbus network maintenance.

Additionally if any alarm is set in the Transducer Block then:

- The associated Segment Alarm DI Block PV_D will be set to 1.
- The associated Active diagnostic bit will be set to 1 (assuming that the appropriate map bit is set).

By configuring the DI block in the fieldbus cyclic messaging the right person can be informed of the alarm condition.

4.2.4 System Transducer Block (SysTB)

There is one SysTB in the F809F-Plus, which allows the user to view system and self-test alarms together with the system power feed voltages and temperature. The SysTB allows configuration of the time, the date and the segments monitored. Additionally, for each device on each of the 8 monitored fieldbus segments, the re-transmission counter can be reset and device history data can be deleted from within this block.

Table 4.4: Measurement Transducer Block Parameters

Rel-index	Parameter Name	Description	Help Text	Default alarm limit
0	BLOCK_HEADER	In the BLOCK_HEADER record of a transducer block only the element BLOCK_TAG is writable.		
1	ST_REV	The revision level of the static data associated with the function block.		
2	TAG_DESC	The user description of the intended application of the block.		
3	STRATEGY	The strategy field can be used to identify grouping of blocks.		
4	ALERT_KEY	The identification number of the plant unit.		
5	MODE_BLK	The ACTUAL, TARGET, PERMITTED, and NORMAL modes of the block. For further description, see the Mode parameter formal model in FF-890.		
6	BLOCK_ERR	This parameter reflects the error status associated with the hardware or software components associated with a block. Multiple errors may be shown. For a list of enumeration values, see FF-890, Block_Err formal model.		
7	UPDATE_EVT	Update Event		
8	BLOCK_ALM	Block Alarm		
9	TRANSDUCER_DIRECTORY	Transducer Directory		
10	TRANSDUCER_TYPE	Transducer Type		
11	XD_ERROR	XD Error		
12	COLLECTION_DIRECTORY	Collection Directory		
13	PRIMARY_VALUE_D			
14	POWER_FEED_A_VOLTAGE	Power Feed A Voltage		
15	POWER_FEED_B_VOLTAGE	Power Feed B Voltage		
16	MODULE_TEMPERATURE	Module Temperature		
17	SYSTEM_ALARMS	System Alarms	Module temperature high and high-high alerts; Power feed B voltage low-low, low, high and high-high alerts; Power feed A voltage low-low, low, high and high-high alerts;	
18	LATCHING_ALARM_ACKNOWLEDGE		Acknowledges all active alarms in this transducer block.	
19	ALARM_ACKNOWLEDGE_REQUIRED		New alarms require acknowledgement.	
20	SELF_TEST_FAULT_ALARMS	Self Test Fault Alarms		
21	SELF_TEST_LOG_1			
22	SELF_TEST_LOG_2			
23	POWER_FEED_A_VOLTAGE_LIMITS	Power Feed A Voltage Limits	The default values are limits for MTL fieldbus power supply input voltages. The user may reset to output limits of bulk power supply taking into account voltage drop in wiring at minimum and maximum load.	Low Low = 19.2V Low = 19.2V High = 30V High High = 30V
24	POWER_FEED_B_VOLTAGE_LIMITS	Power Feed B Voltage Limits	The default values are limits for MTL fieldbus power supply input voltages. The user may reset to output limits of bulk power supply taking into account voltage drop in wiring at minimum and maximum load.	Low Low = 19.2V Low = 19.2V High = 30V High High = 30V

continued

25	MODULE_TEMPERATURE_LIMITS	Module Temperature Limits	The default values are limits for the F801 fieldbus power supply maximum operating temperature of 65°C. The user may reset this to the maximum operating temperature of the power supply used or select a lower limit based on normal operating temperature of the cabinet. Setting the limit at the lower of the maximum operating temperature of the power supply or 10°C above the normal operating temperature is recommended.	High = 65°C High High = 65°C
26	RESET_MEASUREMENT_PROCESSOR_	Reset Measurement Processor	Reset measurement processor to recover from fault state. Warning! Resetting measurement processor will delete device and segment tag data. Ensure this is backed up and download these parameters after reset.	
27	SET_DATE_TIME	Set Date Time	Set the time manually if the Host does not support an automatic update.	
28	SET_MONITORED_SEGMENTS	Set Monitored Segments	The default value is to monitor all 8 segments. If any segments are not in use these may be omitted from the scan. Whilst investigating an issue on a segment, select only that segment number to scan only that segment. After resolving the issue scanning should be reset to all active segments.	
29	SET_NON_SCANNING_SEGMENTS_TO_NULL		The default is to display the last measured values for the segment. If any segments are not in use it is recommended to set to display null values and disable scanning on these segments.	
30	RESET_RETRANSMIT_COUNTERS_METHODS (SELECT_BITMAP, SEGMENT_NR, DEVICE_NR)		Parameter associated with method to delete selected retransmission counters.	
31	DELETE_SGM_DEV_DATA_METHODS (SELECT_BITMAP, SEGMENT_NR, DEVICE_NR)		Parameter associated with method to delete device history data..	
32	RESET_RETR_COUNT_U	Reset Transmission Counters	Parameter used to delete selected retransmission counters in systems not supporting methods.	
33	DEL_DATA_U	Delete data	Parameter used to delete selected device history in systems not supporting methods. Warning! This will delete all history data for the selected device. Device data is stored with the device address assigned by the host system. Only delete data if a device address will be no longer used on a segment or a device address is to be assigned to a different device type.	
34	SET_ALARMS_TO_LATCH		Set if alarm acknowledgement is required. Default is alarms do not require acknowledgement.	

4.2.4.1 System alarms

Value	Name and Description	Help Text
0x80000000	Power Feed A Voltage High-High Alarm	check bulk power supply operation
0x40000000	Power Feed A Voltage High Alarm	
0x20000000	Power Feed A Voltage Low Alarm	
0x10000000	Power Feed A Voltage Low-Low Alarm	
0x08000000	Power Feed B Voltage High-High Alarm	
0x04000000	Power Feed B Voltage High Alarm	
0x02000000	Power Feed B Voltage Low Alarm	
0x01000000	Power Feed B Voltage Low-Low Alarm	
0x00800000	Module Temperature High-High Alarm	check cooling in power supply cabinet
0x00400000	Module Temperature High Alarm	

4.2.4.2 Self test alarms

Value	Name and Description	Help Text
0x8000	Measurement processor in Fault State	
0x4000	EEPROM not programmed	
0x2000	EEPROM data corrupt	
0x1000	Relay stuck	
0x0800	RAM error	
0x0400	FLASH corrupt	
0x0200	Watchdog failure	
0x0100	Data corrupt	
0x0080	Internal watchdog reset	
0x0040	Processor to Processor communication lost	
0x0020	Incompatible Firmware	

If any segments are not in use they may be omitted from the scan using the Set Monitored Segments parameter. It is recommended that non-scanning segments are set to display 'null' values, this avoids the confusion of old data being displayed when scanning is disabled. The default is to 'maintain last values', which is usually preferred when scanning is temporarily disabled; for example, while troubleshooting a segment.

The default configuration is for the F809F-Plus alarms to Auto acknowledge, so the operator would observe the alarms when the Instrument Management Software displays an alarm in the F809F-Plus transducer block. In applications where it is required for the operator to acknowledge transducer block alarms, then the Set Alarms to Latch parameter should be set for the System and Segment Transducer Blocks.

The default configuration sets the same limits for alarms and pre-alarms. The low and high alarm limits may be optimised by the user as described in the parameter help text.

4.2.4.3 Methods

For FOUNDATION™ fieldbus hosts or configuration tools that support DD methods, there are 4 configuration methods available in the Systems Transducer block. These methods are included with the device description (DD) software.

- Setting Date and Time
- Resetting retransmission counter
- Deleting device data
- System Alarm Limits Optimisation

Hosts that do not support DD Methods

For hosts that do not support DD methods, resetting retransmission counters and deleting device data can be performed using parameters in the System Transducer Block. This is described in the parameter help text.

4.2.5 Segment Transducer Block (SegTB)

Each of the eight monitored fieldbus segments is supported by a SegTB that provides all the measured parameters and associated alarms for the fieldbus segment and devices. The user can assign segment and device tags within this block. Additionally the segment and device alarm limits may be changed by the user.

	WARNING
	The device tags are held in volatile memory. The F809F-Plus is designed to be powered by redundant reliable power feeds. If both power feeds fail at the same time, or the F809F-Plus is removed from the carrier, then the segment and device tag data will be lost. It is recommended to retain this data in the systems Instrument Management Software, so if an F809F-Plus module is replaced, the data can be downloaded to the new module.

Table 4.5: Segment Transducer Block Parameters

Rel-index	Parameter Name	Description	Help Text	Default alarm limit
0	BLOCK_HEADER			
1	ST_REV	The revision level of the static data associated with the function block.		
2	TAG_DESC	The user description of the intended application of the block.		
3	STRATEGY	The strategy field can be used to identify grouping of blocks.		
4	ALERT_KEY	The identification number of the plant unit.		
5	MODE_BLK	The actual, target, permitted, and normal modes of the block. For further description, see the Mode parameter formal model in FF-890.		
6	BLOCK_ERR	This parameter reflects the error status associated with the hardware or software components associated with a block. Multiple errors may be shown. For a list of enumeration values, see FF-890, Block_Err formal model.		
7	UPDATE_EVT	Update Event		
8	BLOCK_ALM	Block Alarm		
9	TRANSDUCER_DIRECTORY	Transducer Directory		
10	TRANSDUCER_TYPE	Transducer Type		
11	XD_ERROR	XD Error		
12	COLLECTION_DIRECTORY	Collection Directory		
13	PRIMARY_VALUE_D			
14	MONITORING_STATUS	Monitoring status. Status options are: segment monitored; segment not monitored, last values displayed; segment not monitored, null values displayed		
15	SEGMENT_TAG	The user description of the segment		
16	SEGMENT_VOLTAGE	Segment Voltage		
17	AVG_LF_NOISE	Average Low Frequency Noise	Average low frequency noise (250Hz - 3.8kHz)	
18	AVG_IF_NOISE	Average In-Band Frequency Noise	Average in-band or fieldbus frequency noise (5 kHz - 55kHz)	
19	AVG_HF_NOISE	Average High Frequency Noise	Average high frequency noise (90 kHz - 350kHz)	
20	PEAK_LF_NOISE	Peak Low Frequency Noise	Peak low frequency noise (250Hz - 3.8kHz) detected by the diagnostic module over the last hour.	
21	PEAK_IF_NOISE	Peak In-Band Frequency Noise	Peak in-band or fieldbus frequency noise (5 kHz - 55kHz) detected by the diagnostic module over the last hour.	
22	PEAK_HF_NOISE	Peak High Frequency Noise	Peak high frequency noise (90 kHz - 250kHz) detected by the diagnostic module over the last hour.	
23	LIVE_DEVICE_COUNT	Live Device Count	Number of fieldbus devices communicating on the network segment.	
24	LAS_DEVICE_TAG	LAS Device Tag		
25	LAS_DEVICE_ADDRESS	LAS Device Address	Address of the Link Active Scheduler on the network segment.	
26	LAS_SIGNAL_LEVEL	LAS Signal Level	Peak-to-peak signal level of the Link Active Scheduler transmissions on the network segment.	
27	LOWEST_SIGNAL_DEVICE_TAG	Lowest Signal Device Tag See Note 2 on next page	Tag of the device on the network segment with the lowest detected signal level in the hour.	

continued

28	LOWEST_SIGNAL_DEVICE_ADDRESS	Lowest Signal Device Address See Note 2 on next page	Address of the device on the network segment with the lowest detected signal level in the hour.	
29	LOWEST_SIGNAL_LEVEL	Lowest Signal Level See Note 2 on next page	The lowest detected signal level at which a device transmitted in the hour.	
30	RETRANSMISSIONS	Retransmissions	Total retransmissions monitored by diagnostic module of all devices on this segment since last reset.	
31	RETRANSMISSION_RATE	Retransmission Rate	Retransmission rate = Average Retransmission Rate for all devices on this segment. See Note 1 on next page	
32	DEVICE_DATA_1	Device Data 1		
	DEVICE_ADDRESS	Device Address	Device address. Some fieldbus control systems display addresses as decimal so care should be taken when comparing data in the diagnostic module and the control system.	
	DEVICE_TAG	Device Tag	User assigned device tag. Stored in volatile memory.	
	DEVICE_SIGNAL_LEVEL	Device Signal Level		
	RETRANSMISSIONS	Retransmissions,	Retransmissions detected by diagnostic module for this device since last reset.	
	RETRANSMISSION_RATE	Retransmission Rate	Retransmission rate = Re-transmissions/pass token requests from LAS. See Note 1 on next page	
	RESERVED	Reserved		
	INVERTED_SIGNAL	Inverted Signal	Indicates this device is connected with the wrong polarity. Reverse wiring connections at this device.	
	DEVICE LIVE	Device live status	Live device flag. The device is currently live if this is set to 1. The device is no longer live if 0.	
33 - 63	As 32 for Devices 2 - 32			
64	SEGMENT_ALARMS	See Section 4.2.5.1		
65	DEVICE_ALARMS	See Section 4.2.5.2		
66	LATCHING_ALARM_ACKNOWLEDGE			
67	ALARM_ACKNOWLEDGE_REQUIRED			
68	SEGMENT_VOLTAGE_LIMITS	Segment voltage limits	Default high limit set to 32V and low limit set to 20v for F801 power supply. Set to 25V for FPS power supply and 28V for F802 power supply.	Low Low = 20V Low = 20V High = 32V High High = 32V
69	AVG_LF_NOISE_HIGH_LIMIT	Average Low Freq. Noise High Limit	Default set to 150mV	High = 150mV High High = 150mV
70	AVG_IF_NOISE_HIGH_LIMIT	Average In-Band Freq. Noise High Limit	Default set to 75mV	High = 75mV High High = 75mV
71	AVG_HF_NOISE_HIGH_LIMIT	Average High Frequency Noise High Limit	Default set to 150mV	High = 150mV High High = 150mV
72	PEAK_LF_NOISE_HIGH_LIMIT	Peak Low Frequency Noise High Limit	Default set to 65535mV	High = 65535mV High High = 65535mV (Alarm disabled)

continued

73	PEAK_IF_NOISE_HIGH_LIMIT	Peak In-Band Frequency Noise High Limit	Default set to 65535mV	High = 65535mV High High = 65535mV (Alarm disabled)
74	PEAK_HF_NOISE_HIGH_LIMIT	Peak High Frequency Noise High Limit	Default set to 65535mV	High = 65535mV High High = 65535mV (Alarm disabled)
75	LIVE_DEVICE_COUNT_LIMITS	Live Device Count Limits	Default high limit set to 32 devices and low limit set to 0	Low Low = 0 Low = 0 High = 32V High High = 32V
76	DEVICE_SIGNAL_LEVEL_LIMITS_1	Device Signal Level Limits 1	After successful commissioning the device low limit may be set to 75% of current value and device high limit to 125% of current value.	Low Low = 150mV Low = 150mV High = 1200mV High High = 1200mV
77	RETRANSMISSIONS_LIMIT_1	Retransmissions Limit 1	Default set to 65535	High = 65535mV
78	RETRANSMISSION_RATE_LIMIT_1	Retransmission Rate Limit 1	Default set to 0.1%	High = 0.1%
...	As 76, 77 and 78 for Devices 2 to 31	...		
169	DEVICE_SIGNAL_LEVEL_LIMITS_32	Device Signal Level Limits 32		Low Low = 150mV Low = 150mV High = 1200mV High High = 1200mV
170	RETRANSMISSIONS_LIMIT_32	Retransmissions Limit 32	Default set to 65535	High = 65535
171	RETRANSMISSION_RATE_LIMIT_32	Retransmission Rate Limit 32	Default set to 0.1%	High = 0.1%

Information on alarms is provided by SEGMENT_ALARMS and DEVICE_ALARMS.

NOTE 1

The Retransmission Rate provides an excellent indicator for the quality of fieldbus segment communications.

To provide an accurate Retransmission Rate, a large sample of Pass Token message replies needs to be monitored. To provide useful data at all times - even just after power is connected to the F809F-Plus, or after the retransmission counter is reset - the device calculates the retransmission rate in three phases.

- a) To avoid the risk of nuisance alarms during the initial phase from 1 to 5,000 Pass Tokens (typically 6 hours when 8 segments are being monitored), the displayed value will approach the actual value from below.
- b) During the averaging phase from 5,000 to 100,000 Pass Tokens (typically 6 days when 8 segments are being monitored) the accuracy of the displayed value increases.
- c) In normal operation, with greater than 100,000 Pass Tokens monitored, the F809F-Plus displays a moving average retransmission rate that avoids nuisance alarms from typical events whilst providing good response to changes in fieldbus communications performance.

NOTE 2

The hour means a 60 minute period starting at "the top of the hour" e.g. 0900 to 1000.

4.2.5.1 SEGMENT_ALARMS - Descriptions and Corrective Actions

Dec. value	Hex Value	Name and Description	Help Text
2147483648	0x80000000	Segment Voltage High-High Alarm	Check fieldbus power supply operation
1073741824	0x40000000	Segment Voltage High Alarm	
536970912	0x20000000	Segment Voltage Low Alarm	Check fieldbus power supply operation
268435456	0x10000000	Segment Voltage Low-Low Alarm	
134217728	0x08000000	Average Low Frequency Noise High-High Alarm	Check: fieldbus screening is correctly cut back and taped at each end of the fieldbus device; fieldbus screen connections are correctly made in Fieldbus Barrier Junction Box, intermediate junction boxes, in marshalling cabinet, FP32 surge protector and connected to F618D and grounding connection of F618D; AC cabling close to fieldbus cabling; wire terminations are properly secured.
67108864	0x04000000	Average Low Frequency Noise High Alarm	
33554432	0x02000000	Average In Band Frequency Noise High-High Alarm	Check: fieldbus screening is correctly cut back and taped at each end of the fieldbus device; fieldbus screen connections are correctly made in Fieldbus Barrier Junction Box, intermediate junction boxes, in marshalling cabinet, FP32 surge protector and connected to F618D and grounding connection of F618D; AC cabling close to fieldbus cabling; wire terminations are properly secured. Check for welding on plant or poor grounding of frequency controlled drives.
16777216	0x01000000	Average In Band Frequency Noise High Alarm	
8388608	0x00800000	Average High Frequency Noise High-High Alarm	Check: for sources of high frequency noise such as welding on plant, poor grounding of frequency controlled drives.
4194304	0x00400000	Average High Frequency Noise High Alarm	
2097152	0x00200000	Peak Low Frequency Noise High-High Alarm	If frequent alarms, check: fieldbus screening is correctly cut back and taped at each end of the fieldbus device; fieldbus screen connections are correctly made in Fieldbus Barrier Junction Box, intermediate junction boxes, in marshalling cabinet, FP32 surge protector and connected to F618D and grounding connection of F618D; AC cabling close to fieldbus cabling; wire terminations are properly secured.
1048576	0x00100000	Peak Low Frequency Noise High Alarm	
524288	0x00080000	Peak In Band Frequency Noise High-High Alarm	If frequent alarms, check: for operation of radios with Effective Radiated Power (ERP) of up to 5W being used within 1.5m of fieldbus devices, junction box or cabling; fieldbus screening is correctly cut back and taped at each end of the fieldbus device; fieldbus screen connections are correctly made in Fieldbus Barrier Junction Box, intermediate junction boxes, in marshalling cabinet, FP32 surge protector and connected to F618D and grounding connection of F618D; AC cabling close to fieldbus cabling; wire terminations are properly secured. Check for welding on plant or poor grounding of frequency controlled drives.
262144	0x00040000	Peak In Band Frequency Noise High Alarm	
131072	0x00020000	Peak High Frequency Noise High-High Alarm	If frequent alarms, check: for operation of radios with Effective Radiated Power (ERP) of up to 5W being used within 1.5m of fieldbus devices, junction box or cabling; for welding on plant or poor grounding of frequency controlled drives.
65536	0x00010000	Peak High Frequency Noise High Alarm	
32768	0x00008000	Live Device Count High Alarm	Check if additional device has been added to segment, if new device is approved and segment documentation has been updated, reset live device count limits;

continued

16384	0x00004000	Live Device Count Low Alarm	If alert not cleared immediately on acknowledgement, check for device failed or removed for maintenance. If alert cleared immediately on acknowledgement, this is an indication of intermittent communication. Check trunk cabling, host and trunk JB connections are tight; for water in trunk or spur cable, junction boxes; host operation; spur cabling, spur and device connections are tight; for water in device; for device operation.
8192	0x00002000	+ve short to shield	Check: fieldbus screening is correctly cut back and taped at each end of the fieldbus device; fieldbus screen connections are correctly made in Fieldbus Barrier Junction Box, intermediate junction boxes, in marshalling cabinet, FP32 surge protector and connected to F618D and grounding connection of F618D. Disconnect portions of cable and check if the short goes away. Verify the fieldbus power supply is isolated from ground. Check for damaged or waterlogged cable, junction box or device.
4096	0x00001000	-ve short to shield	
2048	0x00000800	32 device addresses used	Check if any devices will no longer be used on the segment and delete history of these devices.

4.2.5.2 DEVICE_ALARMS - Descriptions and Corrective Actions

Dec. value	Hex Value	Name and Description	Corrective Action
32768	0x8000	Device Signal Level High-High Alarm	If only one device high: check alarm limits have not been wrongly set, check device operation. If several/all devices on segment check for only one terminator on segment or failed terminator.
16384	0x4000	Device Signal Level High Alarm	
8192	0x2000	Device Signal Level Low Alarm	If only one device low: check alarm limits have not been wrongly set, check spur cabling, spur and device connections are tight, water in spur cable or device, check device operation. If several/all devices on segment low check for more than two terminators on segment, check for water in devices, junction boxes and cabling.
4096	0x1000	Device Signal Level Low-Low Alarm	
2048	0x0800	Retransmissions High Alarm	Check retransmission limit has not been wrongly set. Check retransmission rate. Check for changes in parameter levels compared to values at commissioning and with history. Investigate any significant changes.
1024	0x0400	Retransmission Rate High-High Alarm	Reserved for future use
512	0x0200	Retransmission Rate High Alarm	This is an excellent key performance indicator of device communication health. Check retransmission rate limit has not been wrongly set. Check for changes in parameter levels compared to values at commissioning and with history. Investigate any significant changes. If only one device: check spur cabling, spur and device connections are tight, check for water in spur cable or device, check device operation. If all/several devices on segment: check trunk cabling, host and trunk JB connections are tight, check for water in trunk or spur cable, junction boxes or all devices, check host operation.

4.2.5.3 DEVICE_ALERTS - Descriptions

These alerts are useful during commissioning and maintenance. To avoid high levels of alarms, these alerts do not set the "BLOCK_ERR needs maintenance soon" bit, the "DI block alarm" diagnostic bits or the segment LED to "flashing". On an operational fieldbus segment, these events can be set to generate alarms - if required, by configuring "segment device count" low and high alarms.

Value	Name	Description
0x0100	New Device	When new device is added to segment, this alert is displayed for one hour. It does not set the "Device needs maintenance soon" bit.
0x0080	Device Removed	When an established device is removed from a segment, this alert is displayed for one hour. It does not set the "Device needs maintenance soon" bit.

4.3 Discrete Input Block

The discrete input blocks calculate their PV_D value from the current values of the alarm parameters of the transducer blocks and calculate the OUT_D value according to the Discrete Input Block algorithm.

Alarm DI Block: PV_D will be set to 1 if any of the System Alarm, Segment / Device Alarm or Self Test Fault Alarm bits is set. Selected by channel value 12.

System Alarm DI Block: PV_D will be set to 1 if any System Alarm and Self Test Fault Alarm bits are set. Selected by channel value 13.

Segment Alarm DI Block 1 – 8: PV_D will be set to 1 if any of the Segment / Device Alarm bits is set for the rsp. segment. Selected by channel values 14 – 21 for segments 1 – 8.

The selection, which summarized alarm is displayed in which DI function block is adjustable through the CHANNEL parameter of the function block. The default value of the CHANNEL parameter (valid values are 12 to 21) pre-selects the various types of alarms as described above.

Channels Summary:	Channel	Description
	12	Alarm DI Block
	13	System Alarm DI Block
	14	Segment 1 Alarm DI Block
	15	Segment 2 Alarm DI Block
	16	Segment 3 Alarm DI Block
	17	Segment 4 Alarm DI Block
	18	Segment 5 Alarm DI Block
	19	Segment 6 Alarm DI Block
	20	Segment 7 Alarm DI Block
	21	Segment 8 Alarm DI Block

For applications using DI Blocks to communicate alarms to the host system, configure the links between the function blocks and schedule the order of their execution.

4.3.1 Discrete Input Block Errors

The following conditions are reported in the BLOCK_ERR parameters. Conditions in bold are supported in the DI blocks.

Table 4.6. Block/Transducer Error

BLOCK_ERR

Condition Number	Name and Description
0	Other
1	Block configuration error
2	Link configuration error
3	Simulate active
4	Local override
5	Device fault state set
6	Device needs maintenance soon
7	Input failure
8	Output failure
9	Memory failure
10	Lost static data
11	Lost NV data
12	Readback check failed
13	Device needs maintenance now
14	Power up: The device was just powered up
15	Out of service: The actual mode is out of service

5 OPERATION AND MAINTENANCE

5.1 LED indicators

Power status (green)

ON	power on
OFF	power off/fail

Segment status (amber)

ON	segment monitored
OFF	segment not monitored
FLASHING	active segment alarm

5.2 FOUNDATION™ fieldbus Information

FOUNDATION™ fieldbus is an all-digital, serial, two-way, multidrop communication protocol that interconnects devices such as transmitters and valve controllers. It is a local area network (LAN) for instruments that enables basic control and I/O to be moved to the field devices. The model F809F-Plus uses FOUNDATION™ fieldbus technology developed and supported by Eaton and the other members of the independent Fieldbus FOUNDATION™.

5.2.1 Commissioning (Addressing)

To be able to setup, configure, and have it communicate with other devices on a segment, a device must be assigned a permanent address. Unless requested otherwise, it is assigned a temporary address when shipped from the factory.

If there are two or more devices on a segment with the same address, the first device to start up will use the assigned address (ex. Address 20). Each of the other devices will be given one of the four available temporary addresses. If a temporary address is not available, the device will be unavailable until a temporary address becomes available.

Use the host system documentation to commission a device and assign a permanent address.

5.3 Hardware Maintenance

The F809F-Plus has no moving parts and requires a minimal amount of scheduled maintenance. If a malfunction is suspected, check for an external cause before performing the diagnostics presented below.

5.3.1 Communication/Power Check

If the Fieldbus Diagnostic Module does not communicate, or provides an erratic output, check for adequate voltage to it. The F809F-Plus requires between 9.0 and 32.0V DC on the communicating fieldbus segment. This is selected as Segment 1 or 8 of the monitored segment or a separate fieldbus segment. Check for wire shorts, open circuits, and multiple grounds on the communicating fieldbus segment.

5.3.2 Resetting the Configuration (RESTART)

The Restart Processor parameter in the Resource Block offers the choice of:

- a) an uninitialised restart that restarts the processor with the current configuration, or
- b) a default restart that restores the default configuration.

Note: Following a default restart the block is in OOS Mode. The block must be manually placed back into Auto Mode.

- a) Restart resource, is accepted, but no function executed.
- b) Run is the normal state for the block. To clear field after a Processor restart the parameter should be manually set to Run with some systems.
- c) Restart processor will trigger an immediate reset of the processor. As the F809F-Plus does not acknowledge the request this may cause an error message with some systems.

5.4 Troubleshooting

5.4.1 FOUNDATION™ fieldbus

Symptom	Possible Cause	Corrective Action
Device does not show up in the live list	<p>Network configuration parameters are incorrect</p> <p>Network address is not in polled range.</p> <p>Power to the device is below the 9 VDC minimum.</p> <p>Noise on the power / communication is too high.</p>	<p>Set the network parameters of the LAS (host system) according to the FF Communications Profile: ST: 8 MRD: 10 DLPDU PhLO: 4 MID: 7 TSC: 4 (1 ms) T1: 1920000 (60 s) T2: 5760000 (180 s) T3: 480000 (15 s)</p> <p>Set first Unpolled Node and Number of UnPolled Nodes so that the device address is within range. Increase the voltage to at least 9V.</p> <p>Verify terminators and power conditioners are within specification Verify that the shield is properly terminated and not grounded at both ends. It is best to ground the shield at the power conditioner.</p>
Device that is acting as a LAS does not send out CD	LAS Scheduler was not downloaded to the Backup LAS device	Ensure that all of the devices that are intended to be a Backup LAS are marked to receive the LAS schedule
All devices go off live list and then return	Live list must be reconstructed by Backup LAS device	Current link setting and configured links settings are different. Set the current link setting equal to the configured settings.

5.4.2 Resource Block

Symptom	Possible Cause	Corrective Action
Mode will not leave OOS	<p>Target mode not set</p> <p>Memory Failure</p>	<p>Set target mode to something other than OOS.</p> <p>BLOCK_ERR will show the lost NV Data or Lost Static Data bit set. Restart the device by setting RESTART to Processor. If the block error does not clear, call the factory.</p>
Block Alarms Will not work	<p>Features</p> <p>Notification</p>	<p>FEATURES_SEL does not have Alerts enabled. Enable the report bit. LIM_NOTIFY is not high enough. Set equal to MAX_NOTIFY.</p>

5.4.3 System and Segment Transducer Block Troubleshooting

Symptom	Possible Cause	Corrective Action
Mode will not leave OOS	<p>Target mode not set</p> <p>Resource block</p>	<p>Set target mode to AUTO</p> <p>The actual mode of the Resource block is in OOS therefore set target mode to AUTO.</p>

Appendix A: Troubleshooting Table

Symptom	Possible Causes
High peak or average noise	Water/condensation in wiring, improperly connected shield, bad fieldbus device, bad physical layer component (power supply, terminator, wiring block), segment is not isolated from ground, fieldbus cable is located near noise producing cable, loose wire termination.
Recommendations: Inspect the network cable and connections. Tighten screw terminals and connector hold-down screws. Look for waterlogged cables, condensation in junction boxes, loose wires, FF cable routed near other signaling cables or AC power cables, loose strands of wire shorting to other wires/conductive objects. Check if fieldbus to shield short is present and if so follow recommendations below. Verify the segment is powered by an isolated fieldbus power supply or that the bulk supply for the fieldbus power supply is isolated and only powers one segment. Take noise measurements at multiple locations on the network to identify where noise is highest and most likely located. Measure resistance from shield to ground with a DMM and verify it is <100Ω. Disconnect devices one at a time to see if noise disappears. Replace terminators, fieldbus power supplies, and wiring blocks.	

Symptom	Possible Causes
Excessive retransmissions rate (on one device)	Bad spur wiring connection to device, not enough power to the device, bad device, bad port on the wiring block, noise on the spur.
Recommendations: Check if high noise levels are present and if so follow recommendations above. If the wiring block has a current limiting (SpurGuard™) feature, check the associated LED to make sure it isn't constantly or intermittently lit. Inspect the wiring and connections from the wiring block to the device looking for waterlogged cables, condensation in junction boxes, loose wires, FF cable routed near other signaling cables or AC power cables, loose strands of wire shorting to other wires/conductive objects. Try putting the device on a different spur from the wiring block. Replace the device.	

Symptom	Possible Causes
Excessive retransmissions rate (on all or multiple devices)	Wiring problem, not enough power to the devices, bad physical layer device (power supply, terminator, wiring block), noise on the bus
Recommendations: Determine if the entire network is affected or just part of it. Focus on the part of the network with problems. Check if high noise levels are present and if so follow recommendations above. Use the FBT-3/6 to check for high noise levels at the device and check the bus voltage is >9VDC at the device furthest from the power supply. Inspect the network looking for waterlogged cables, condensation in junction boxes, loose wires, FF cable routed near other signaling cables or AC power cables, loose strands of wire shorting to other wires/conductive objects. Replace the terminators, power supply/conditioner.	

Symptom	Possible Causes
Low device signal level (one device)	Bad spur wiring connection to device, not enough power to the device, bad device, bad port on
Recommendations: Use FBT-3/6 to check the voltage at the device is >9VDC. If the wiring block has a current limiting (SpurGuard™) feature, check the associated LED to make sure it isn't constantly or intermittently triggered. Inspect the wiring and connections from the wiring block to the device looking for waterlogged cable, condensation, loose wires, loose strands of wire shorting to other wires/ conductive objects. Verify the maximum length of cable between any 2 devices does not exceed 1900m and spur length does not exceed 120m. Try connecting the device on a different spur from the wiring block. Replace the device.	

Symptom	Possible Causes
Low device signal level (all devices)	Wiring problem, not enough power to the devices, bad physical layer device (power supply, terminator, wiring block)
Recommendations: Use FBT 3/6 to check the voltage at the device furthest from it is >9VDC. Check the power LEDs on the wiring blocks are steadily lit. Inspect the wiring and connections (especially at the parts common to all devices such as power supply/conditioner, terminators, trunk cable, etc.) looking for waterlogged cable, condensation, loose wires, loose strands of wire shorting to other wires / conductive objects. Replace suspect physical layer components (power supply/ conditioner, terminators, wiring blocks).	

continued

Symptom**Possible Causes****High device signal level (one device)**

Bad device

Recommendations: Replace the device.

Symptom**Possible Causes****High device signal level (all devices)**

Missing terminator, failed terminator, improperly connected terminator, failed fieldbus power supply

Recommendations: Verify two terminators are installed (note that some terminators are built-in to power supplies/conditioners and wiring blocks, some are turned on/off with a switch and some are automatic). Check wiring to the terminators. Replace suspect terminators or the products that contain them. Replace the fieldbus power supply.

Symptom**Possible Causes****Shield short to fieldbus**

Wiring problem, un-isolated device connected to the fieldbus, water in a cable/device/wiring block

Recommendations: Check for damaged cable, make sure all devices are properly connected. Verify that fieldbus is not connected to a ground at the power supply or to a device case. Look for shield connections to the fieldbus cable including stray strands of wire at wire terminations or un-insulated shield wire loose at the device. Disconnect portions of cable and check if the short goes away. Verify the fieldbus power supply is isolated from ground.

Symptom**Possible Causes****Device is not "seen" on the bus/not communicating**

Bad spur wiring connection to device, not enough power to the device, bad device, bad port on the wiring block

Recommendations: Check DC voltage at the device is >9VDC. If the wiring block the device is connected to has a current limiting (SpurGuard™) feature, check the associated LED to make sure it isn't constantly or intermittently triggered. Inspect the wiring and connections from the wiring block to the device looking for waterlogged cable, condensation, loose wires, loose strands of wire shorting to other wires/conductive objects. Try putting the device on a different spur from the wiring block. Replace the device.

this page is left intentionally blank

this page is left intentionally blank

AUSTRALIA

MTL Instruments Pty Ltd,
10 Kent Road, Mascot, New South Wales, 2020, Australia
Tel: +61 1300 308 374 Fax: +61 1300 308 463
E-mail: mtl-salesanz@eaton.com

BeNeLux

MTL Instruments BV
Ambacht 6, 5301 KW Zaltbommel
The Netherlands
Tel: +31 (0) 418 570290 Fax: +31 (0) 418 541044
E-mail: mtl.benelux@eaton.com

CHINA

Cooper Electric (Shanghai) Co. Ltd
955 Shengli Road, Heqing Industrial Park
Pudong New Area, Shanghai 201201
Tel: +86 21 2899 3817 Fax: +86 21 2899 3992
E-mail: mtl-cn@eaton.com

FRANCE

MTL Instruments sarl,
7 rue des Rosiéristes, 69410 Champagne au Mont d'Or
France
Tel: +33 (0)4 37 46 16 53 Fax: +33 (0)4 37 46 17 20
E-mail: mtlfrance@eaton.com

GERMANY

MTL Instruments GmbH,
Heinrich-Hertz-Str. 12, 50170 Kerpen, Germany
Tel: +49 (0)22 73 98 12 - 0 Fax: +49 (0)22 73 98 12 - 2 00
E-mail: csckerpen@eaton.com

INDIA

MTL India,
No.36, Nehru Street, Off Old Mahabalipuram Road
Sholinganallur, Chennai - 600 119, India
Tel: +91 (0) 44 24501660 / 24501857 Fax: +91 (0) 44 24501463
E-mail: mtlindiasales@eaton.com

ITALY

MTL Italia srl,
Via San Bovio, 3, 20090 Segrate, Milano, Italy
Tel: +39 02 959501 Fax: +39 02 95950759
E-mail: chmninfo@eaton.com

JAPAN

Cooper Crouse-Hinds Japan KK,
MT Building 3F, 2-7-5 Shiba Daimon, Minato-ku,
Tokyo, Japan 105-0012
Tel: +81 (0)3 6430 3128 Fax: +81 (0)3 6430 3129
E-mail: mtl-jp@eaton.com

NORWAY

Norex AS
Fekjan 7c, Postboks 147,
N-1378 Nesbru, Norway
Tel: +47 66 77 43 80 Fax: +47 66 84 55 33
E-mail: info@norex.no

RUSSIA

Cooper Industries Russia LLC
Elektrozavodskaya Str 33
Building 4
Moscow 107076, Russia
Tel: +7 (495) 981 3770 Fax: +7 (495) 981 3771
E-mail: mtlrussia@eaton.com

SINGAPORE

Cooper Crouse-Hinds Pte Ltd
No 2 Serangoon North Avenue 5, #06-01 Fu Yu Building
Singapore 554911
Tel: +65 6645 9864 / 6645 9865 Fax: +65 6 645 9865
E-mail: sales.mtlsing@eaton.com

SOUTH KOREA

Cooper Crouse-Hinds Korea
7F, Parkland Building 237-11 Nonhyun-dong Gangnam-gu,
Seoul 135-546, South Korea.
Tel: +82 6380 4805 Fax: +82 6380 4839
E-mail: mtl-korea@eaton.com

UNITED ARAB EMIRATES

Cooper Industries/Eaton Corporation
Office 205/206, 2nd Floor SJ Towers, off. Old Airport Road,
Abu Dhabi, United Arab Emirates
Tel: +971 2 44 66 840 Fax: +971 2 44 66 841
E-mail: mtlgulf@eaton.com

UNITED KINGDOM

Eaton Electric Limited,
Great Marlings, Butterfield, Luton
Beds LU2 8DL
Tel: +44 (0)1582 723633 Fax: +44 (0)1582 422283
E-mail: mtl-enquiry@eaton.com

AMERICAS

Cooper Crouse-Hinds MTL Inc.
3413 N. Sam Houston Parkway W.
Suite 200, Houston TX 77086, USA
Tel: +1 281-571-8065 Fax: +1 281-571-8069
E-mail: mtl-us-info@eaton.com