

F101, F102, F104

Fieldbus Power Supply



DECLARATION OF CONFORMITY

A printed version of the Declaration of Conformity has been provided separately within the original shipment of goods. However, you can find a copy of the latest version at -

<http://www.mtl-inst.com/certificates>

CONTENTS

1	OVERVIEW	1
2	DESCRIPTION	1
3	COMPONENTS AND ACCESSORIES	2
4	MECHANICAL	2
4.1	Mounting Orientation	2
4.2	Enclosure Requirements	2
4.3	DIN-rail Mounting	3
4.4	Removal from DIN-rail	4
5	ELECTRICAL CONNECTIONS	4
5.1	DC Power Requirements	5
5.2	Power Connector Wiring	5
5.3	DIN-rail bussing	6
5.4	Terminator	6
5.5	Fieldbus Connections	7
5.6	Fieldbus Cable Screen	7
6	TESTING	7
6.1	F10x Status LEDs	7
7	ROUTINE MAINTENANCE	8
8	FM CONTROL DRAWINGS	9
9	ATEX & UKCA SAFETY INSTRUCTIONS	10
9.1	General	10
9.2	Installation	11
9.3	Inspection and maintenance	11
9.4	Repair	11
9.5	Marking	12

GENERAL SAFETY INFORMATION

The following methods are used in this manual to alert the user to important information:-

	WARNING ! Warnings are provided to ensure operator safety and MUST be followed.
-----------------------------------------------------------------------------------	--------------------------------------------------------------------------------------------------

CAUTION Cautions are provided to prevent damage to the instrument.

NOTE These are used to give general information to ensure correct operation.

SAFETY INSTRUCTIONS FOR INSTALLATION AND OPERATING PERSONNEL

The operating instructions provided here contain **essential safety instructions** for installation personnel and those engaged in the operation, maintenance and servicing of the equipment.

	WARNING ! Failure to comply with these instructions can endanger the lives or health of personnel and risk damage to the plant and the environment.
-----------------------------------------------------------------------------------	----------------------------------------------------------------------------------------------------------------------------------------------------------------------

	WARNING ! The responsibility for planning, installation, commissioning, operation and maintenance, particularly with respect to applications in explosion-hazard areas, lies with the plant operator.
-----------------------------------------------------------------------------------	------------------------------------------------------------------------------------------------------------------------------------------------------------------------------------------------------------------------

Before commencing installation or commissioning:

- Read and understand the contents of this manual and the product datasheet
- Ensure installation and operating personnel have received adequate training for this task
- Ensure that any operating instructions are fully understood by the personnel responsible.
- Observe national and local installation and mounting regulations (e.g. IEC 60079-14).

	WARNING ! If these assemblies have been used previously in general electrical installations, they MAY NOT be used in explosion-hazard area applications.
-------------------------------------------------------------------------------------	---------------------------------------------------------------------------------------------------------------------------------------------------------------------------

During operation:

- Make the relevant instructions available at all times to the operating personnel.
- Observe safety instructions.
- Observe national safety and accident prevention regulations.
- Operate the equipment within its published specification.
- Servicing, maintenance work or repairs not described in this manual must not be performed without prior agreement with the manufacturer.
- Any damage to this equipment may render its explosion protection null and void.
- No changes to any of the components that might impair their explosion protection are permitted.

If any information provided here is not clear:

- Contact Eaton's MTL product line support or one of its representatives.

NOTE Improper installation and operation of the enclosure can result in the invalidation of the warranty.



Figure 1: F101-PS

1 OVERVIEW

The F101, F102, and F104 (F10x) Fieldbus Power Supplies are designed to provide power for a single FOUNDATION fieldbus™ H1 or Profibus PA segment. Galvanic isolation, power conditioning and segment termination are incorporated into each F10x module. Termination of the fieldbus segments is normally enabled with a switch on the module, but may be switched off for those few applications that do not require a Terminator at the Fieldbus Power Supply.

2 DESCRIPTION

For extreme reliability, the modules use passive components for power conditioning and a reliable DC/DC converter to provide galvanic isolation and power regulation. The connectors used for power input and the Fieldbus output are high quality pluggable types with screw retention. Spring-clamp (-PC) and screw terminal (-PS) connector versions are supported.

LED indicators show the status of the modules. In normal operation, the green Power LED is lit, showing that there is proper input voltage to the module and the red Fault LED is off. If the fieldbus segment is shorted or in an over-current condition the Fault LED blinks. An internal module error is indicated by a steady light on the red Fault LED. The status of the internal terminator switch is also indicated by an illuminated 'T' symbol.

The modules can be powered from a supply between 19.2 – 30.0 VDC (10.0 – 30.0 VDC for the F104). The incoming power can be applied via the top-mounted connector which supports onward looping of power wiring, or by using a proprietary plug-in connector on a DIN-rail bussing system.

3 COMPONENTS AND ACCESSORIES

Product part numbers and their descriptions are given below.

PART No.	DESCRIPTION
F101-P*	Fieldbus Power Supply: 21.5V, 500mA
F102-P*	Fieldbus Power Supply: 28V, 500mA
F104-P*	Fieldbus Power Supply: 13V, 250mA
PBUS01	Power Bus DIN-rail connectors, pack of 5
PBUS02	Power Bus DIN-rail input plug and socket set
PBUS03	End Stop/Strain relief clamps, pack of 2

* = S – Pluggable Screw Terminal Connectors

C – Pluggable Spring Clamp Connectors

4 MECHANICAL

4.1 Mounting Orientation

The F10x Fieldbus Power Supplies are designed for mounting on a horizontally aligned DIN-rail on a vertical surface. This method of mounting ensures optimum heat dissipation.

4.2 Enclosure Requirements

4.2.1 General Requirements

The assembly may be mounted in hazardous (classified) areas – see Sections 8 & 9. The following conditions must also be satisfied to ensure safe and reliable operation.

- a) Prevent any form of pollution that could compromise the operation of the unit. For example, choose an unpolluted location or a suitable enclosure to protect the assembly.
- b) Provide an adequate level of mechanical protection. This can be achieved by selecting a protected location, a suitable enclosure, or a combination of both.
- c) Ensure that all cable entries and connections are secure by making provision for the careful routing and securing of all cables.
- d) Provide adequate security against unauthorized interference.
- e) Ensure that the permitted ambient temperature range of -40°C to $+65^{\circ}\text{C}$ ($+70^{\circ}\text{C}$ if load is 400mA or less) is not exceeded. Allow for power dissipation within the enclosure and consider the use of shading against direct sunlight.

4.2.2 Outdoor Mounting

If the F10x is mounted in an outdoor location, use a suitable enclosure with a minimum of IP54 ingress protection. A higher level of ingress protection rating will be necessary if the working atmosphere is or can be corrosive or if the enclosure is subject to wet or dusty environments.

4.3 DIN-rail Mounting

The F10x is designed for mounting on 35mm x 7.5mm T-section “top hat” DIN rail to EN50022 and uses an integrated DIN-rail clamp to hold it onto the rail. If the DIN-rail bussing system is to be used, the bussing connectors must first be attached to the DIN-rail.

For vertical DIN Rail installations, we recommend using a DIN Rail clamp below the F10x modules (see accessory PBUS03) to prevent the units from sliding on the DIN Rail.

4.3.1 Mounting Procedure

The F10x is mounted to the DIN-rail by hooking the side opposite the DIN-rail latch to the DIN Rail. The device is then pivoted to fit on the DIN-rail. Then the latch is pushed toward the DIN-rail and snaps in place holding the F10x firmly on the DIN-rail.

For applications using the DIN-rail bussing connectors, the DIN-rail bussing connector must first be snapped onto the DIN Rail – see Figure 4a. The F10x is then installed over the DIN-rail bussing connector making sure that it is properly lined up (Figure 4b).

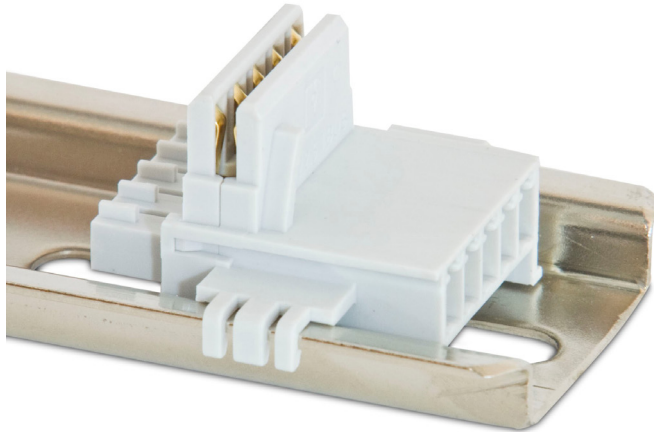

Figure 4a

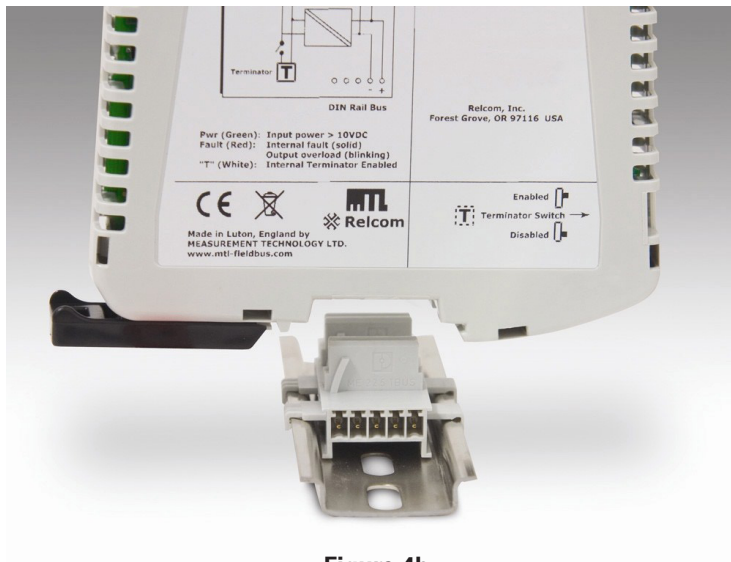

Figure 4b

4.4 Removal from DIN-rail

To remove the F10x from the DIN-rail, use a screwdriver to release the DIN-rail latching mechanism. Pivot the F10x and remove from the DIN-rail.

5 ELECTRICAL CONNECTIONS

The Input power and Fieldbus Segment connectors are pluggable and available in a screw terminal version (-PS) or a spring clamp version (-PC). See Figures 5a & 5b. The terminals can accept the following conductor sizes:

Type	Conductor size
Screw terminals (-PS)	0.14 to 2.5mm ²
Spring clamp terminals (-PC)	0.2 to 2.5mm ²



Figure 5a: Screw Terminal

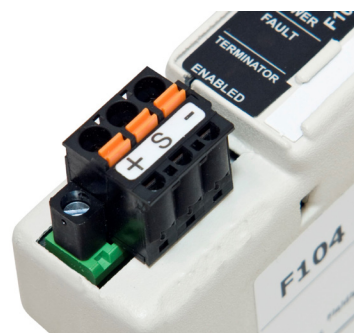

Figure 5b: Spring Clamp

NOTE

When wiring to spring-clamp terminals use a screwdriver with a 3-4 mm blade and depress the spring-clamp button (orange) before inserting the termination cable. See Figure 5b.

5.1 DC Power Requirements

Power terminals requiring a nominal input voltage of 24VDC are provided allowing the use of bulk power supplies with a supply range of 19.2–30VDC (10–30VDC for the F104). Input power cabling and over-current protection devices must be chosen to match the current consumption.

Typical input current at 24VDC input for a fully loaded F10x is shown in the table below. The input current is load and input voltage dependent. To determine the expected input current for a specific application, see the graphs in the F10x Product Specification document. If the power is 'daisy-chained' using the top-mounted F10x connectors, size the input fusing accordingly and keep the total current below 8A. Each F10x module contains an internal 1.5A fuse (not user replaceable).

Module	Input Current
F101	550mA
F102	700mA
F104	200mA

It is also important to size the Bulk Power Supply to handle the inrush current required by the F10x. Inrush is less than 3 times the maximum rated current with a duration lasting less than 2ms.

5.2 Power Connector Wiring

There are two pairs of positive and negative terminals on the input power connector. The pairs are internally connected together to allow 'daisy-chaining' of power from one unit to another. Wiring of two independent power supplies (for redundancy) to the input power connector is not permitted unless external steering diodes are included in each source of supply. DC supply connections are as follows:

Input Power	
Pin No.	Connection
7	+ve
8	-ve
9	+ve
10	-ve

Cable lengths on the Power connectors should not exceed 30m nor go outside the building.

It is important to note that because the input wire pairs are internally connected on the F10x printed circuit board, unplugging the 4 way connector will disrupt the daisy chained power. To prevent unexpected loss of power downstream of the F10x, the bulk power should be routed to each end of the daisy chain. This way, unplugging one F10x 4 way connector will not disrupt other devices.

5.3 DIN-rail bussing

Rather than using the top 4 way connectors to provide power to the F10x, an optional DIN-rail bussing system is available. This is very convenient when multiple F10x units are in the same cabinet. One DIN-rail bussing connector is needed for each F10x module. In addition a Female and/or Male connector that mates to the DIN-rail bussing connector is needed to wire the input power to the series of bussing connectors. Use a Female on one end and a male on the other to buss power from both directions in case the string of bussing connectors might need to be separated at some time. There is also an end stop/cable strain relief device that is available – see the accessory parts in section 3.

Power supplied to the DIN-rail bussing chain should be limited by a fuse to 8A maximum. Use the table in section 5.1 to determine the maximum number of F10x modules that can be connected in one DIN-rail bussing chain.

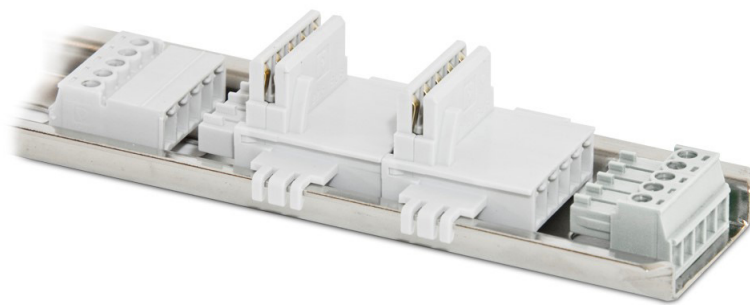

Figure 5c

5.4 Terminator

The F10x module contains a Terminator that is activated by a switch. The Terminator switch is in the ON position from the factory. Graphics on the label on the side of the F10x indicates the switch location and the orientation that enables and disables the Terminator – see Figure 5d. A white LED illuminates a “T” on the top of the unit whenever the Terminator is enabled – see Figure 5e. Most applications will take advantage of the internal Terminator in the F10x.



Figure 5d



Figure 5e

5.5 Fieldbus Connections

There are two 3 way connectors (internally wired together) for connection to a Host and Field cable. Each connector provides (+), (-) and cable screen (S) connections. See section 5.6 for information on cable screen grounding.

Pin No.	Connection
1	Fieldbus +
2	Fieldbus S
3	Fieldbus -

Pin No.	Connection
4	Fieldbus +
5	Fieldbus S
6	Fieldbus -

The host cable length should not exceed 30 meters.

5.6 Fieldbus Cable Screen

The Fieldbus standard requires that the Cable Screen be grounded. There are no facilities on the F10x for screen grounding. Therefore, the screen must be grounded at the Host or in a marshalling cabinet.

6 TESTING

6.1 F10x Status LEDs

Each F10x is fitted with two LEDs, one to indicate input power status and one to signify an error condition.

Fault Condition	Power LED	Fault LED
No Fault	On	Off
Input < 10V (F104)	Off	-
Input < 19V (F101, F102)	Off	-
Segment shorted	-	Blinking Red
Internal Module Fault	-	Red

7 ROUTINE MAINTENANCE

Check the general condition of the installation occasionally to make sure that no deterioration has occurred. At least every two years (and more frequently for particularly harsh environments) check:

- the condition of wire connections, terminations, and screens.
- the dc output voltage on one of the fieldbus connectors is >21.8V for the F101, >28.3V for the F102, or >13.1V for the F104. This can be performed using a multi-meter or a Relcom FBT-6 Fieldbus Monitor.
- the Green input power LED is lit, and the Red Fault LED is off.
- there are no signs of damage or corrosion.



WARNING !
POTENTIAL ELECTROSTATIC CHARGING HAZARD – IF CLEANING OF THE UNIT IS NECESSARY, USE A DAMP CLOTH TO PREVENT STATIC BUILDUP

8 FM CONTROL DRAWINGS

HAZARDOUS (CLASSIFIED) LOCATION

Class I, Division 2, Groups ABCD T4
 Class I, Zone 2, IIC T4 (US only)
 Ex nA nL IIC T4 (Canada only)
 -40°C ≤ Tamb ≤ 65°C
 -40°C ≤ Tamb ≤ 70°C (load ≤ 400mA)

WARNING - EXPLOSION HAZARD. DO NOT DISCONNECT EQUIPMENT WHEN A FLAMMABLE OR COMBUSTIBLE ATMOSPHERE IS PRESENT.

To be installed in an IP54 or better enclosure

F10x Fieldbus Power Supply

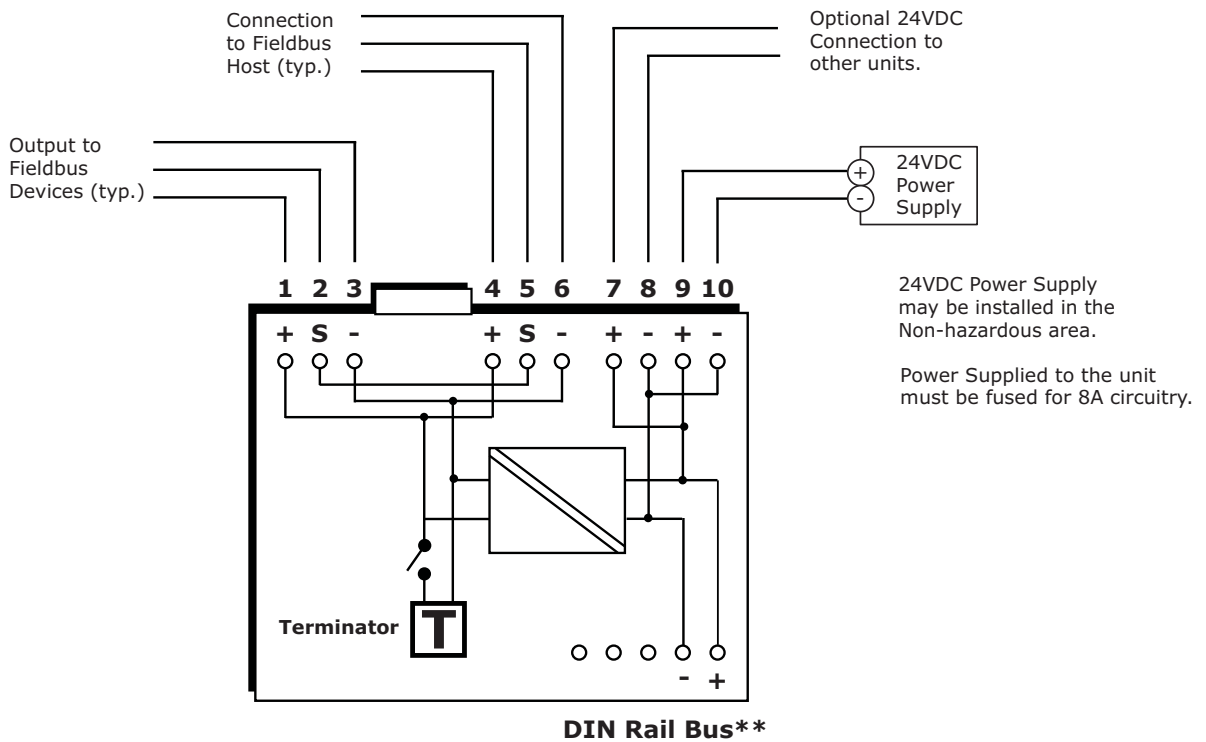

24VDC Power Supply may be installed in the Non-hazardous area.
 Power Supplied to the unit must be fused for 8A circuitry.

Vmax = 24VDC (F101), 30VDC (F102), 14VDC (F104)
 Imax = 580mA (F101), 580mA (F102), 290mA (F104)

** A Bus may be formed with optional components that are installed in the DIN Rail channel. The 24VDC power is supplied to this Bus and connections 7-10 must not be used.

Part Numbers:

F101-P*, F102-P*, F104-P*

"*": S = Pluggable Screw Terminal Connectors
 C = Pluggable Spring Clamp Connectors

Installation must be in accordance with the National Electrical Code (NFPA 70, Article 504), ANSI/ISA-RP12.6, or the Canadian Electrical Code (CSA C22.1), as applicable.

 Relcom Inc. <small>INDUSTRIAL LAN WIRING COMPONENTS AND TESTERS</small> 2221 Yew Street, Forest Grove, Oregon 97116 USA	
Title: CONTROL DRAWING FOR F10x Supplies CLASS I, DIV 2 (ZONE 2) HAZARDOUS LOCATIONS	
Approved By: Mike Strauser	Date: 03/5/13
Drawing Number: 502-531	Rev.: B.0

FM Special Conditions of Use

1. In Class I, Division 2 installations, the subject equipment shall be mounted within a tool secured enclosure which is capable of accepting one or more of the Class I, Division 2 wiring methods specified in the National Electrical Code (ANSI/NFPA 70) for US installations – or Canadian Electrical Code (C22.1) for Canadian installations.
2. In Class I, Zone 2 installations, the subject equipment shall be mounted within a tool secured enclosure which is capable of accepting one or more of the Class I, Division 2 wiring methods specified in the National Electrical Code (ANSI/NFPA 70) for US installations – or Canadian Electrical Code (C22.1) for Canadian installations.
3. When installed in hazardous (classified) locations, a warning label must be prominently affixed near the unit(s) which warns that the cables or Fieldbus Supply Modules must not be removed or inserted unless the area is known to be non-hazardous.
4. In Class I, Zone 2 installations (Canada), the installer shall ensure protection of supply terminals against transient voltages exceeding the rated supply voltage by greater than 40%. The equipment must also be installed in an enclosure with a minimum ingress protection rating of IP54 unless the apparatus is intended to be afforded an equivalent degree of protection by location.

9 ATEX & UKCA SAFETY INSTRUCTIONS

The following information is in accordance with the Essential Health and Safety Requirements:

- (Annex II) of the EU Directive 2014/34/EU [the ATEX Directive- safety of apparatus]
- (Schedule 1) of the Equipment and Protective Systems Intended for Use in Potentially Explosive Atmospheres Regulations 2016 (S.I. 2016/1107)

and is provided for those locations where the ATEX Directive/UK Regulation is applicable.

9.1 General

- a) This equipment must only be installed, operated and maintained by competent personnel. Such personnel shall have undergone training, which included instruction on the various types of protection and installation practices, the relevant rules and regulations, and on the general principles of area classification. Appropriate refresher training shall be given on a regular basis. [See clause 4.2 of EN 60079-17].
- b) This equipment has been designed to provide protection against all the relevant additional hazards referred to in Annex II of the directive, such as those in clause 1.2.7.
- c) This equipment has been designed to meet the requirements of EN 60079-0 and EN 60079-15.
- d) This apparatus provides protection against all the relevant additional hazards referred to in Schedule 1 of the regulation, such as those in clause 13.

9.2 Installation

- a) The installation must comply with the appropriate European, national and local regulations, which may include reference to the code of practice EN 60079-14. In addition, particular industries or end users may have specific requirements relating to the safety of their installations and these requirements should also be met. For the majority of installations the Directive 2014/34/EU [the ATEX Directive - safety of installations] and SI 2016:1107 (amended by SI 2019 No. 696) is also applicable.
- b) This apparatus may be installed in a safe area and also in a Zone 2 location providing that the relevant installation conditions are met. When mounted in a Zone 2 location the apparatus must be provided with an enclosure, which offers an additional degree of protection appropriate to the area classification.
- c) Unless already protected by design, this equipment must be protected by a suitable enclosure against:
 - i) mechanical and thermal stresses in excess of those noted in the certification documentation and the product specification
 - ii) aggressive substances, excessive dust, moisture and other contaminants.

Read also the Special Conditions for Safe Use (below) for any additional or more specific information.

Specific Conditions of Safe Use:

1. The apparatus is to be installed in an enclosure which maintains a minimum ingress protection rating of IP54 and meets the enclosure requirements of EN 60079-0 and EN 60079-15 as appropriate for the installation.
2. Electrostatic Discharge Hazard. Care must be taken to prevent static build-up on the non-metallic case.

9.3 Inspection and maintenance

- a) Inspection and maintenance should be carried out in accordance with European, national and local regulations which may refer to the standard EN 60079-17. In addition specific industries or end users may have specific requirements which should also be met.
- b) Access to the internal circuitry must not be made during operation.

9.4 Repair

This product cannot be repaired by the user and must be replaced with an equivalent certified product.

9.5 Marking

Each device is marked in compliance with the Directive/Regulation.
 This information applies to products manufactured during or after the year 2009.

Typical certification marking

<h1 style="margin: 0;">F102</h1> <h2 style="margin: 0;">Foundation™ Fieldbus Power Supply</h2>	
<p>Zone 2/Division 2</p>	
<p style="text-align: center;">DIN Rail Bus</p>	<p>Input: 19.2-30VDC, 1A max. Output: 27.9-30VDC, 500mA.</p> <p>$-40^{\circ}\text{C} \leq T_a \leq +65^{\circ}\text{C}$ $-40^{\circ}\text{C} \leq T_a \leq +70^{\circ}\text{C}$ (load $\leq 400\text{mA}$)</p> <p> II 3 G Ex nA IIC T4 Gc RELC09ATEX1008</p> <p> RELC21UKEX1013</p> <p> Class I Div 2 ABCD T4 Cl I Zone 2 IIC T4 (US) Ex nA IIC T4 (Canada) Install per 502-531</p>
<p>Pwr (Green): Input power > 19.2VDC Fault (Red): Internal fault (solid) Output overload (blinking) "T" (White): Internal Terminator Enabled</p>	
	<p>502-541 vF0</p>
<p>Made in Luton, England by EATON ELECTRIC LTD. www.mtl-inst.com</p>	
<p>Enabled </p> <p>Terminator Switch </p> <p>Disabled </p>	

This page left intentionally blank

AUSTRALIA

Eaton Electrical (Australia) Pty Ltd,
10 Kent Road, Mascot, New South Wales, 2020, Australia
Tel: +61 1300 308 374 Fax: +61 1300 308 463
E-mail: mtl-salesanz@eaton.com

BeNeLux

MTL Instruments BV
Ambacht 6, 5301 KW Zaltbommel
The Netherlands
Tel: +31 (0) 418 570290 Fax: +31 (0) 418 541044
E-mail: mtl.benelux@eaton.com

CHINA

Cooper Electric (Shanghai) Co. Ltd
955 Shengli Road, Heqing Industrial Park
Pudong New Area, Shanghai 201201
Tel: +86 21 2899 3817 Fax: +86 21 2899 3992
E-mail: mtl-cn@eaton.com

FRANCE

MTL Instruments sarl,
7 rue des Rosiéristes, 69410 Champagne au Mont d'Or
France
Tel: +33 (0)4 37 46 16 53 Fax: +33 (0)4 37 46 17 20
E-mail: mtlfrance@eaton.com

GERMANY

MTL Instruments GmbH,
Heinrich-Hertz-Str. 12, 50170 Kerpen, Germany
Tel: +49 (0)22 73 98 12- 0 Fax: +49 (0)22 73 98 12- 2 00
E-mail: csckerpen@eaton.com

INDIA

MTL India,
No.36, Nehru Street, Off Old Mahabalipuram Road
Sholinganallur, Chennai- 600 119, India
Tel: +91 (0) 44 24501660 /24501857 Fax: +91 (0) 44 24501463
E-mail: mtlindiasales@eaton.com

ITALY

MTL Italia srl,
Via San Bovio, 3, 20090 Segrate, Milano, Italy
Tel: +39 02 959501 Fax: +39 02 95950759
E-mail: chmninfo@eaton.com

JAPAN

Cooper Industries Japan K.K.
MT Building 3F, 2-7-5 Shiba Diamon, Minato-ku
Tokyo, Japan 102-0012
Tel: +81 (0)3 6430 3128 Fax: +81 (0)3 6430 3129
E-mail: mtl-jp@eaton.com

NORWAY

Norex AS
Fekjan 7c, Postboks 147,
N-1378 Nesbru, Norway
Tel: +47 66 77 43 80 Fax: +47 66 84 55 33
E-mail: info@norex.no

RUSSIA

Cooper Industries Russia LLC
Elektrozavodskaya Str 33
Building 4
Moscow 107076, Russia
Tel: +7 (495) 981 3770 Fax: +7 (495) 981 3771
E-mail: mtlrussia@eaton.com

SINGAPORE

Eaton Electric (Singapore) Pte Ltd
100G Pasir Panjang Road
Interlocal Centre
#07-08 Singapore 118523
#02-09 to #02-12 (Warehouse and Workshop)
Tel: +65 6 645 9888 ext 9864/9865
Fax: 65 6 645 9811
E-mail: sales.mtlsing@eaton.com

SOUTH KOREA

Cooper Crouse-Hinds Korea
7F Parkland Building 237-11 Nonhyun-dong Gangnam-gu,
Seoul 135-546, South Korea.
Tel: +82 6380 4805 Fax: +82 6380 4839
E-mail: mtl-korea@eaton.com

UNITED ARAB EMIRATES

Cooper Industries/Eaton Corporation
Office 205/206, 2nd Floor SJ Towers, off. Old Airport Road,
Abu Dhabi, United Arab Emirates
Tel: +971 2 44 66 840 Fax: +971 2 44 66 841
E-mail: mtlgulf@eaton.com

UNITED KINGDOM

Eaton Electric Limited,
Great Marlings, Butterfield, Luton
Beds LU2 8DL
Tel: +44 (0)1582 723633 Fax: +44 (0)1582 422283
E-mail: mtlenquiry@eaton.com

AMERICAS

Cooper Crouse-Hinds MTL Inc.
3413 N. Sam Houston Parkway W.
Suite 200, Houston TX 77086, USA
Tel: +1 800-835-7075 Fax: +1 866-298-2468
E-mail: mtl-us-info@eaton.com