

MTL F810

Redundant fieldbus power system for I/A Series®
control systems

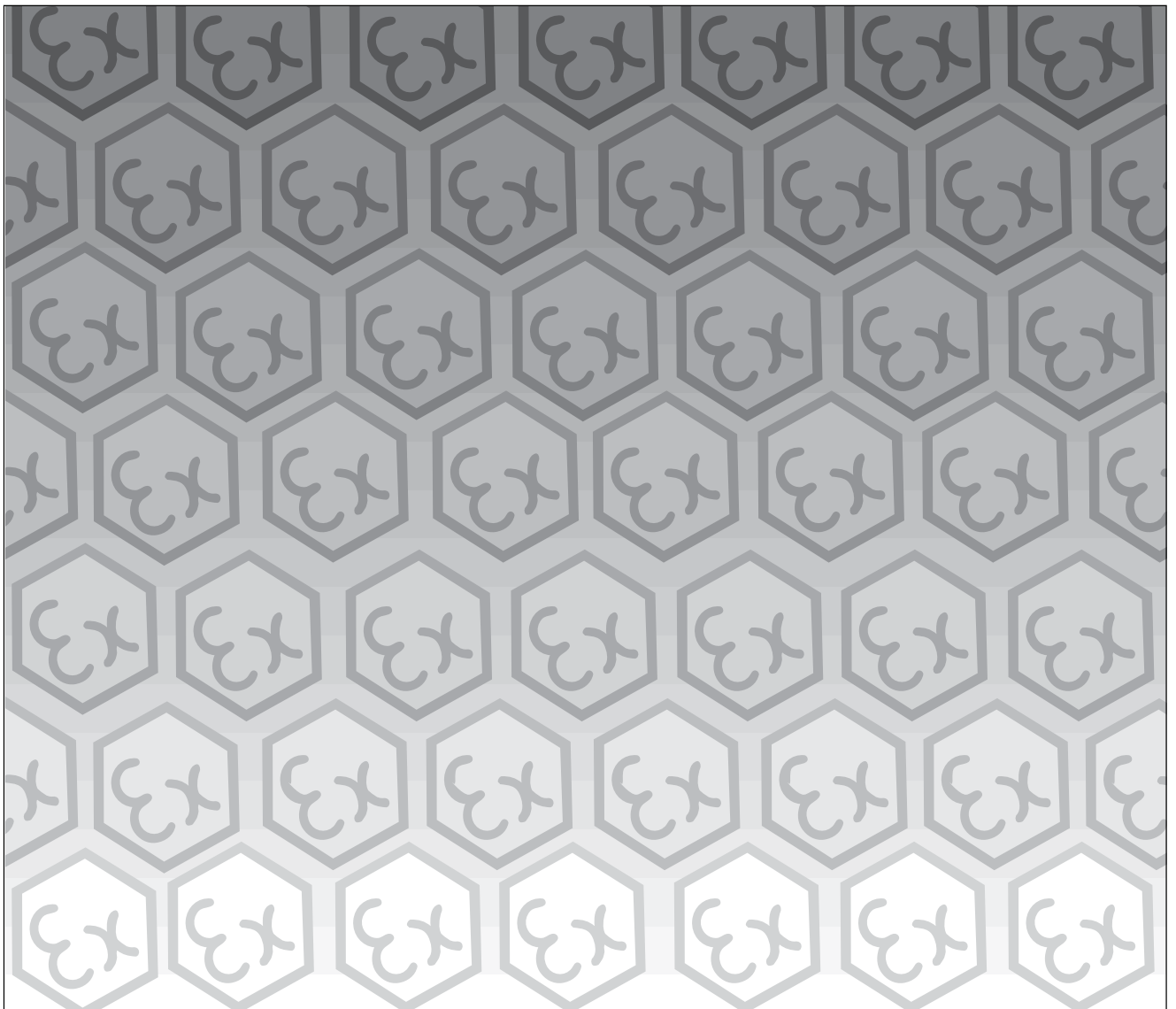

Powering Business Worldwide

Declaration of Conformity

A printed version of the Declaration of Conformity has been provided separately within the original shipment of goods. However, you can find a copy of the latest version at <http://www.mtl-inst.com/certificates>

- DECLARATION OF CONFORMITY II**
- 1 OVERVIEW 1**
- 2 COMPONENTS AND ACCESSORIES 1**
- 3 DESCRIPTION 1**
- 4 MECHANICAL INSTALLATION 2**
 - 4.1 General 2
 - 4.2 Mounting orientation 2
 - 4.3 Baseplate mounting 3
 - 4.5 Mounting and removal of the Power Modules 3
- 5 ELECTRICAL INSTALLATION 3**
 - 5.1 Introduction 3
 - 5.2 Input power connections 4
 - 5.3 Alarm circuit 4
 - 5.4 Module Fieldbus connections 5
 - 5.5 Fieldbus segment connections 5
 - 5.6 Grounding 6
 - 5.7 Diagnostics module 6
 - 5.8 Address switch settings 7
- 6 TESTING & TROUBLESHOOTING 7**
 - 6.1 F80x Status and Alarm LEDs 7
 - 6.2 Testing after installation 7
 - 6.3 Troubleshooting 7
- 7 MAINTENANCE 7**
 - 7.1 Routine maintenance 7

THIS PAGE IS LEFT INTENTIONALLY BLANK

F810 - redundant fieldbus power system for I/A Series® control systems

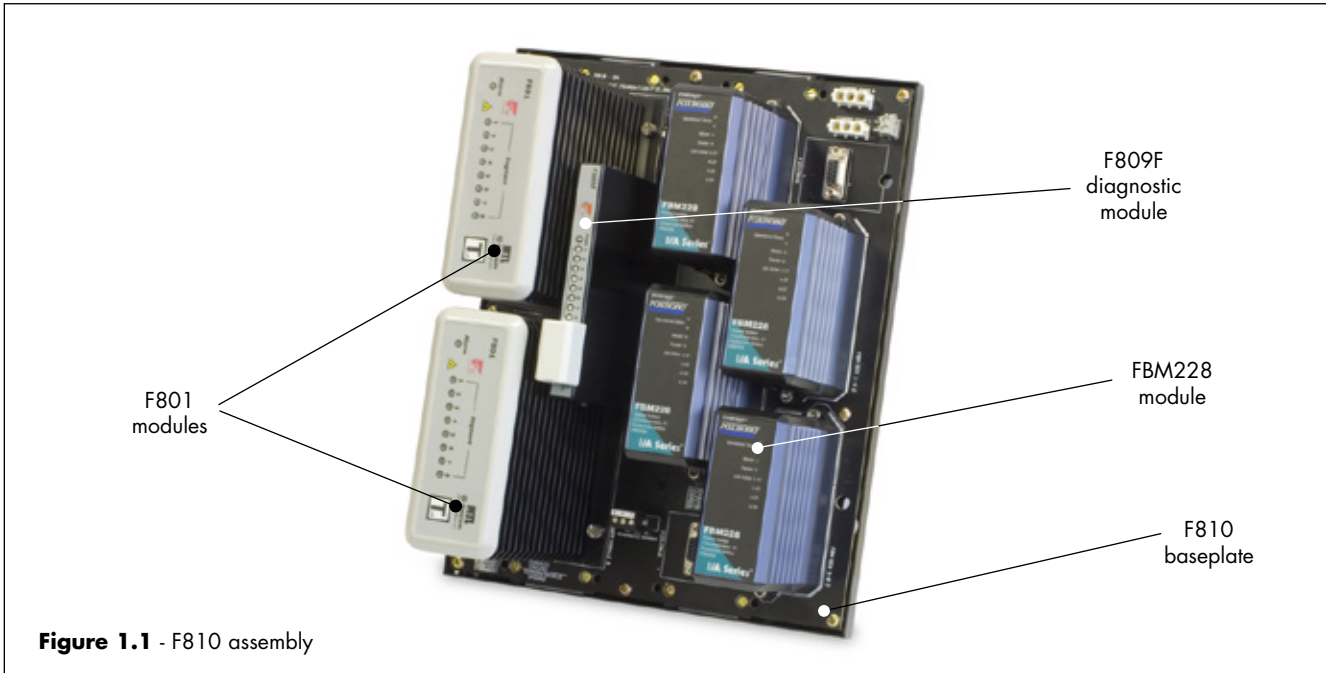

Figure 1.1 - F810 assembly

1 OVERVIEW

This manual explains the installation of the F810 fieldbus power system, which is designed to provide redundant FOUNDATION fieldbus™ power for Foxboro I/A Series® control systems using FBM228 modules. Eight fieldbus segments are supported.

For extreme reliability, the module baseplate has no components and only provides interconnections between FBM228 modules; the F801 or F802 power modules; the F809F diagnostics module and the external connections.

In general purpose, safe area applications, the system is fully 'hot-swappable' - meaning that individual power modules and input power supplies can be replaced without interrupting power or communication on the fieldbus segment, assuming that redundant F80x power modules are fitted.

The system is designed so that power for several fieldbus segments can be provided from a single assembly with minimal wiring.

2 COMPONENTS AND ACCESSORIES

The F810 system comprises the following components.

Description	Part No.
Carrier, unpopulated	F810-CA
8-segment power module: 21.5V, 350mA	F801
8-segment power module: 28V, 500mA	F802
F810 system with pluggable screw terminal connectors and two F801 modules	F810-PS
F810 system with pluggable screw terminal connectors and two F802 modules	F810-2-PS
F810 system with pluggable spring clamp connectors and two F801 modules	F810-PC
F810 system with pluggable spring clamp connectors and two F802 modules	F810-2-PC
Blanking module	F800-BLK
Fieldbus diagnostic module	F809F

Note that the system does not include the Foxboro FBM228 FOUNDATION fieldbus™ interfaces, and that the F809F Fieldbus Diagnostic Module is an optional additional item.

3 DESCRIPTION

The system comprises a baseplate which accommodates two redundant pairs of Foxboro FBM228 modules and two MTL F801 or F802 power modules operating in redundant configuration. Failure alarms, galvanic isolation, power conditioning and segment termination are incorporated into each power module.

Each F80x module has indicator LEDs to show both its status and that of the eight segments under power. In normal operation, each green 'Segment' LED is lit, showing that the segment is powered. If a segment is shorted, or its voltage is below the rated output, this LED is extinguished, and the red 'Alarm' LED is lit. In the alarm condition, a normally closed, galvanically-isolated relay contact goes to an open condition. Connections to the alarm relay are made via screw terminals on the F810 baseplate. If multiple F810 units are used, a common alarm circuit can be achieved by 'daisy-chaining' the alarm circuits.

Any F80x module provides galvanic isolation between the 24V DC input power and the fieldbus segments, as required by the IEC61158-2 fieldbus standard and the Fieldbus Foundation™ FF-831 validation test for power conditioners. There is also galvanic isolation between the fieldbus segments, thereby preventing multiple segment failures from ground faults on more than one segment. Each segment has its own fieldbus power conditioner and current limitation. Termination of the fieldbus segment is automatically maintained when single or redundant F80x modules are fitted.

An F809F diagnostic module may optionally be installed on the carrier, to automatically collect and distribute diagnostic information on each of the eight fieldbus segments. Measured parameters may be viewed in the Foxboro control system by either assigning the F809F as a fieldbus device to segment one or eight, or on a separate segment. Connections for a separate segment are provided on the baseplate. For more information, see the F809F product specification.

Redundant 24V DC (nom.) input power can be connected to the F810 baseplate using Foxboro I/A standard 3-way power connectors. In situations where Foxboro power supplies cannot provide sufficient current, the F80x modules can also be powered separately via additional board-mounted terminals.

Field wiring connections are available with either pluggable screw terminals (F810-PS) or pluggable spring clamp terminals (F810-PC).

I/A Series® is a registered trademark of Invensys plc, London, England

INM MTLF810 rev 2

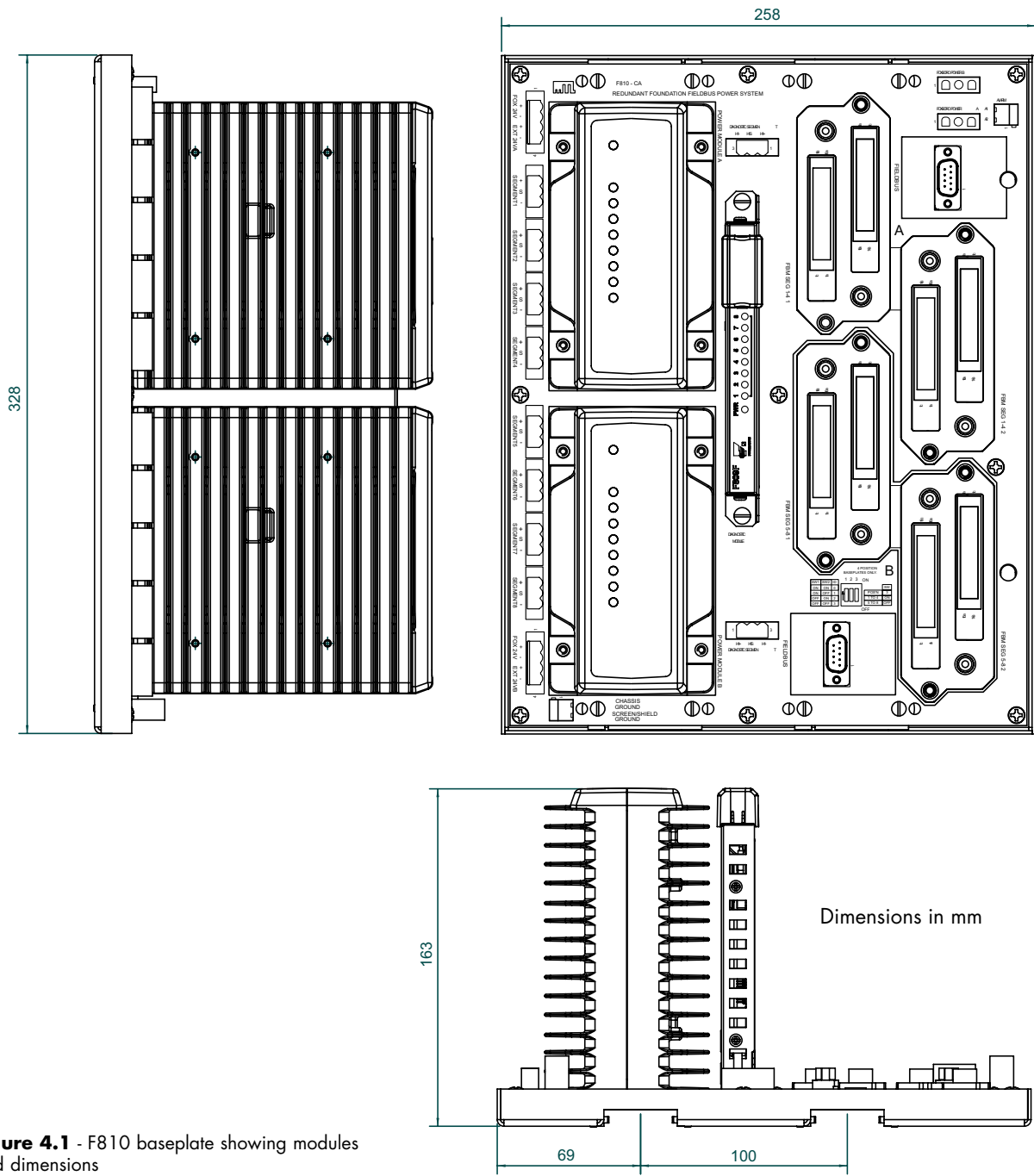

Figure 4.1 - F810 baseplate showing modules and dimensions

4 MECHANICAL INSTALLATION

The layout of the F810 baseplate, including details of the overall dimensions and DIN-rail fixings, is shown in Figure 4.1.

4.1 General

These power systems may be mounted only in safe areas and wherever they are located, the mounting conditions must:

- prevent any form of pollution that could compromise the operation of the unit. For example, an unpolluted location or a suitable enclosure could be chosen.
- provide an adequate level of mechanical protection. This can be achieved by selecting a protected location, a suitable cabinet or enclosure, or a combination of both.
- ensure that all cable entries and connections are secure by making provision for the careful routing and securing of all cables.

- provide adequate security against unauthorised interference.
- ensure that the permitted ambient operating temperature range of the units (-40°C to $+65^{\circ}\text{C}$) is not exceeded. *If F802 Power Modules are to be used at 60% or more of their full-load rating then they must be de-rated to 50°C.* Power dissipation within the cabinet or enclosure and the effect of heating from sunlight exposure should be considered.

4.2 Mounting orientation

It is recommended that the F810 baseplate is mounted on a vertical surface with the orientation of the F80x modules as shown in Figure 4.1 above. Any other orientation will not provide optimum airflow for the F80x power modules. The baseplate is provided with two channels that have clamping tabs for DIN-rail mounting.

4.2.1 Outdoor mounting

If the assembly is to be mounted in an outdoor location, use a suitable enclosure with a minimum of IP54 ingress protection. A higher degree of ingress protection is recommended if the atmosphere can become corrosive, wet or dusty.

4.3 Baseplate mounting

The carrier is designed for mounting on 35mm x 7.5mm T-section "top hat" DIN rail to EN 50022 and uses six built-in DIN clamp tabs to hold it on the rail. The Power Modules (F801 or F802) must be removed from the carrier to obtain access to the DIN-rail clamp screws.

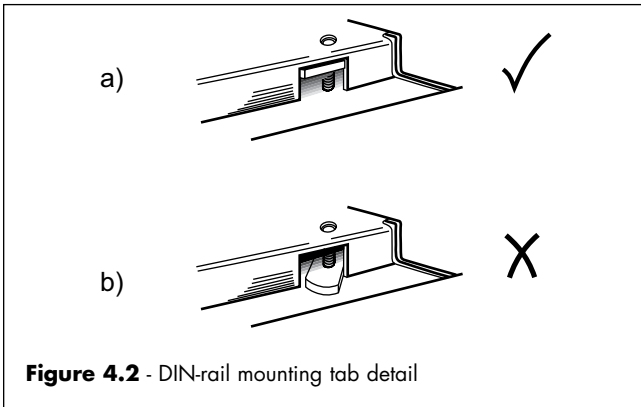

Figure 4.2 - DIN-rail mounting tab detail

4.3.1 Mounting procedure

Before starting to mount the carrier on the DIN rail, rotate each of the clamp screws counterclockwise (i.e. unscrew) until the clamping tabs reach the position shown in Figure 4.2a and none of the tabs extend into the channel for the DIN rail.

Press the carrier onto the DIN rail and rotate each of the clamp screws clockwise until the tab tightens against the rail. The clamping tabs can be seen through the "Inspect clamps" holes in the carrier when they are in the correct position.

4.3.2 Removal from DIN rail

To obtain access to the DIN-rail clamp screws the Power Modules must be removed from the carrier. Support the carrier by pressing it to the DIN rail and unscrew (counterclockwise) the six DIN-rail clamp screws. Turn each screw approximately two full turns to release its clamping tab from the rail. Remove the carrier.

4.5 Mounting and removal of the Power Modules

Each power module has four captive screws to secure it to the carrier. Align the module over its electrical connectors on the carrier, press it to the carrier and hold it in place while tightening the four fixing screws.

To remove a power module, support the module while unscrewing the four fixing screws at its base then lift the module off its carrier connector.

4.5.2 F809F diagnostic module

The F809F diagnostic module is secured to the baseplate with two screw mountings. Use a similar technique to that given above to fit and remove this module.

5 ELECTRICAL INSTALLATION

5.1 Introduction

There are two separate methods of powering the F80x power modules on the baseplate - directly from the Foxboro Power system or through the use of External Power supplies. Both methods are capable of providing redundant power to the F810.

Refer to Figure 5.1 for additional information regarding the two methods.

5.1.1 FBM228 input power

Power for the FBM228 modules is provided solely from the Foxboro A & B power connectors located at the top right-hand corner of the baseplate (see Figures 5.1 and 5.2).

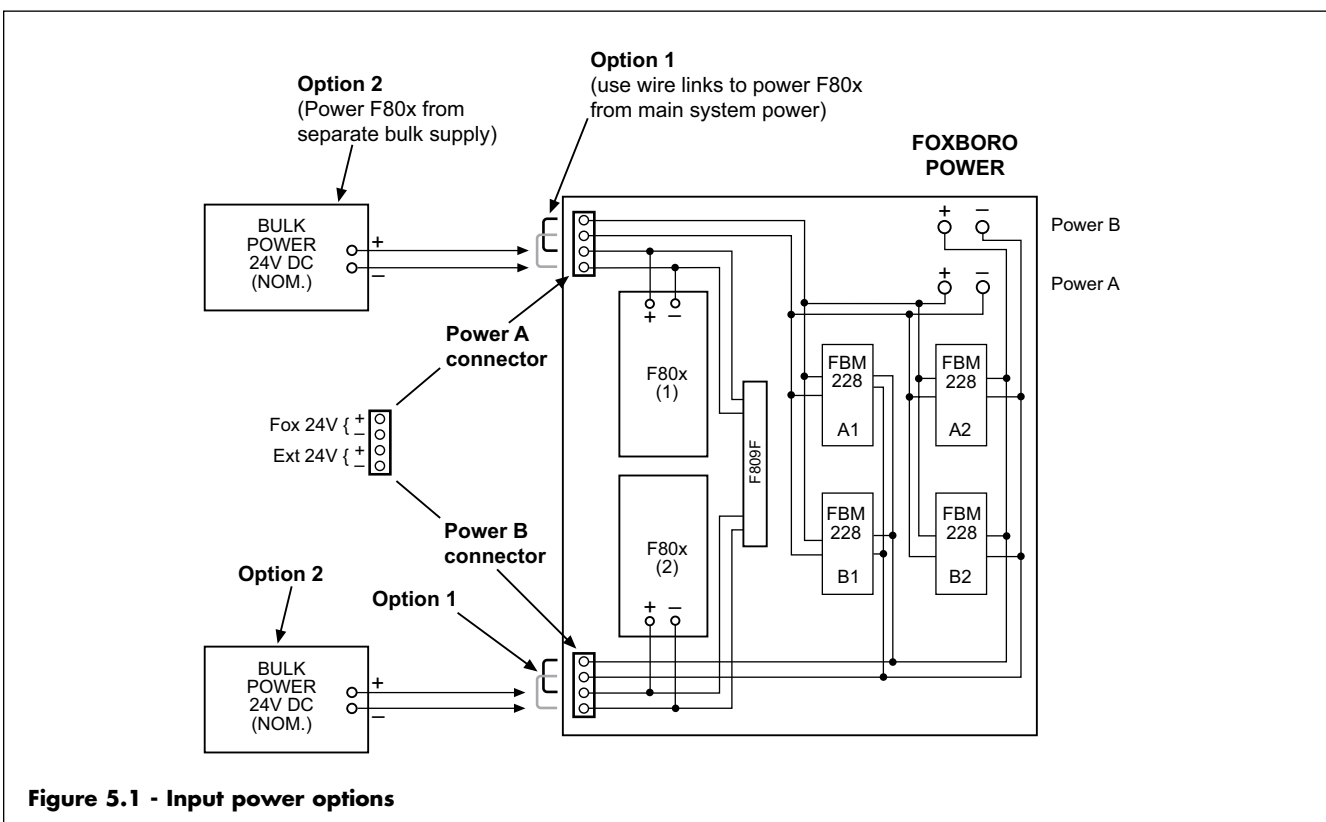

Figure 5.1 - Input power options

5.1.2 Supplying the Power Modules

The input power for the F80x power modules can be supplied in one of two ways, as required.

Option 1 from the regular A & B Foxboro power supplies

Option 2 from one or two external bulk supplies.

See Figure 5.1 for additional details.

The choice normally depends upon the amount of supply current available from the Foxboro Power system.

With 8 segments each drawing 350mA the total current required for the baseplate, including all other modules, is 4.4A.

Note also that the F809F diagnostic module, if fitted, always receives its power in the same way as the F80x modules.

5.1.3 Redundancy

For redundant operation, F80x modules are fitted in Power Module A and Power Module B locations.

For non-redundant operation fit the F80x in the Power Module **A** location.

5.2 Input power connections

CAUTION: All incoming power supplies Foxboro Power (A & B) and/or External Bulk supplies must be isolated before removing or fitting either of the wire links used to configure Option 1 or 2.

5.2.1 Power from Foxboro system only - Option 1

To power the fieldbus Power Modules exclusively from the Foxboro Power system use the connectors located at the top right of the baseplate, as shown in Figure 5.2. These accept standard Foxboro (PO926Kx) style power cables that supply redundant inputs of nominally 24V dc.

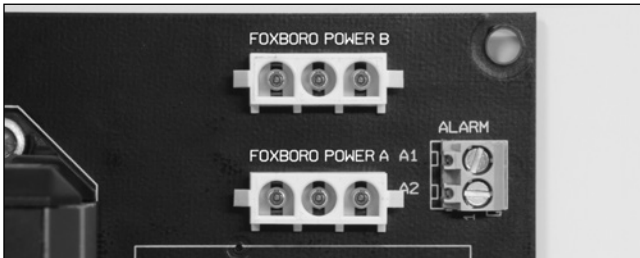

Figure 5.2 - System Power and Alarm connections

When using Option 1 the power connectors locate at the top and bottom left of the baseplate must have wire links in place as illustrated in Figure 5.1. These wire links loop the Foxboro system power into the F80x modules. All power will then be taken from the main Foxboro system supply. Wire links are provided with the baseplate.

5.2.2 Power from other bulk supplies - Option 2

The F80x modules can also be powered separately from external bulk power supplies via additional board-mounted terminals. The upper terminal block supplies Power Module A and the lower terminal block supplies Power Module B - see Figure 5.1.

In order to connect an external bulk supply to one of the terminal blocks, the two wire links must be removed. **See Caution above.**

Remove any wire links from the upper and lower connector blocks (see Figure 5.1) and connect separate external 19.2 - 30.0V DC supplies to the EXT 24V '+' and '-' terminals - observing the correct polarities.

The cable length to these bulk supply inputs shall be limited to a maximum of 30 metres.

5.2.3 Over-current protection

A fully populated F810 baseplate (including both F80x power modules, F809F Fieldbus diagnostic module and FBM228 Fieldbus interface modules) draws a maximum current of 4.4A at 24V DC input (x.xA typical). Suitably rated fuses or circuit breakers must be installed in the primary and secondary 24V DC power supply connections. For example, a rating of 10A is suitable for protection of a single F810 baseplate. This rating is required in the primary and secondary sources of supply, to ensure continued operation in the event of a failure of one supply. If a single method of over-current protection is provided for multiple baseplates, the power supply wiring must be capable of sustaining the short-circuit current.

5.3 Alarm circuit

Each F80x power module contains an alarm relay and the contacts of the relay are normally held closed while the module is in its normal "no alarm" condition.

A shorted segment, the "failure" of any of the incoming bulk power supply, or an F80x module failure, will cause the relay contacts in the F80x module to open, signalling an alarm condition.

5.3.1 Alarm terminals

Two screw terminals A1 & A2 are provided on the baseplate (see Figure 5.2) to make connection to the alarm relay's switch contacts. These terminals are the ends of a series connection of the alarm circuits of both power modules (see Figure 5.3). The alarm contacts may be daisy-chained with the alarm contacts on other F810 baseplates.

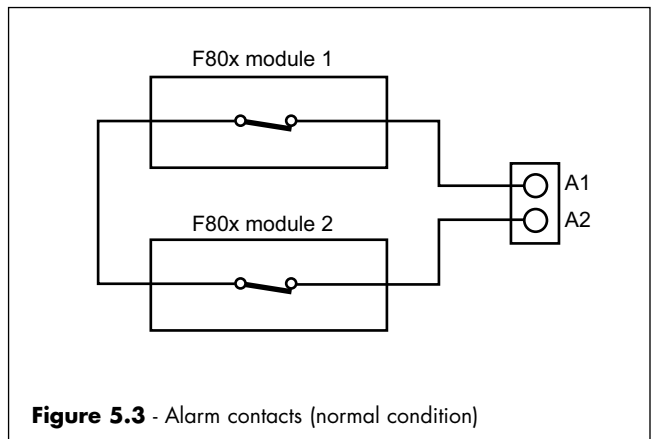

Figure 5.3 - Alarm contacts (normal condition)

5.3.2 Simplex operation

If one of the F80x modules is not fitted; for example in a non-redundant application, or for repair or replacement; a "simplex adapter" (part number F800-BLK - see Figure 5.4) can be fitted to the empty F80x connector position to provide continuity for the alarm circuit (see Section 5.3.1); this prevents an alarm being signalled when one F80x module is absent.



Figure 5.4 - F800-BLK Simplex Adapter

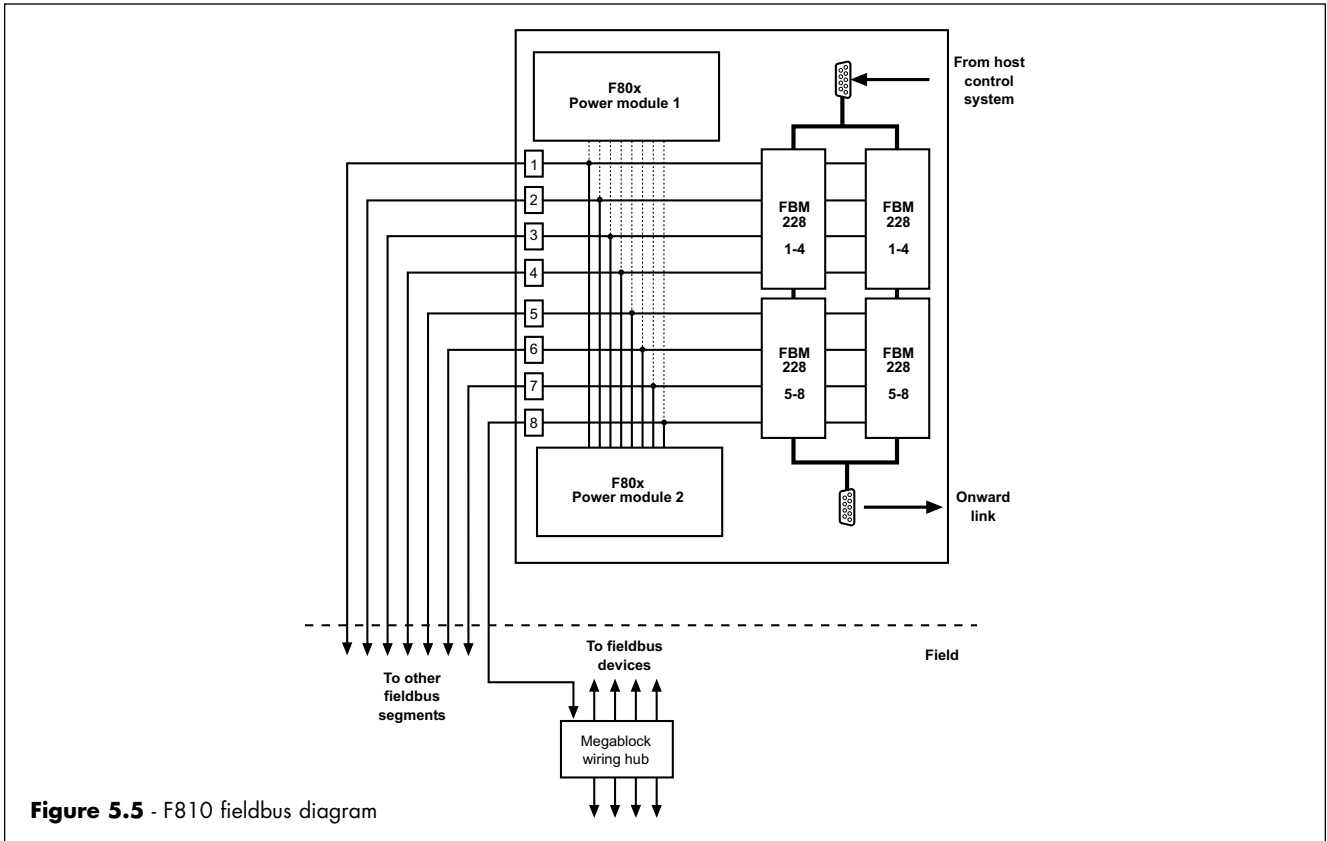

Figure 5.5 - F810 fieldbus diagram

5.4 Module Fieldbus connections

9-pin D-type terminals (see Figure 5.6) are provided top and bottom on the righthand side of the baseplate. These accept standard Foxboro Module Fieldbus cables. The two connectors provide a through path to onward link the fieldbus LAN as shown in Figure 5.5.

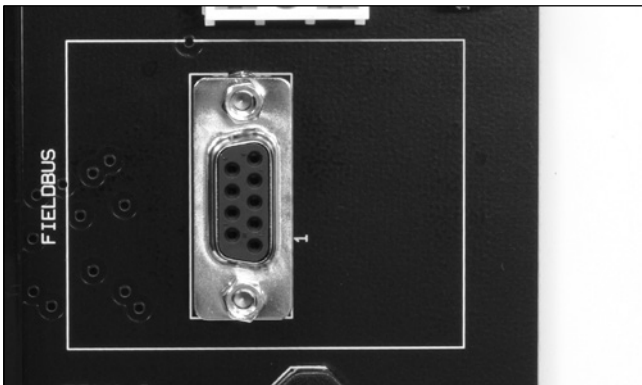

Figure 5.6 - Fieldbus segment connector

5.5 Fieldbus segment connections

The eight fieldbus segments connections are located on the lefthand side of the baseplate beside the F80x power modules - as shown in Figure 5.7. The connectors are pluggable and available in a rising cage clamp screw version (-PS) or a spring clamp version (-PC). See Figure 5.8.

The terminals can accept the following conductor sizes:

Type	Conductor size
Screw terminals (-PS)	0.14 to 2.5mm ²
Spring clamp terminals (-PC)	0.2 to 2.5mm ² flexible or rigid

Note: When wiring to spring-clamp terminals, use a screwdriver with a 3-4 mm blade and depress the spring-clamp button before inserting the termination cable. See Figure 5.8.

If the fieldbus cable screens are to be grounded at the F810 then they should be connected to the 'S' terminal on each connector. However, if they are not grounded at the F810, the screen wire should be cut off and insulated to avoid contact with the board.

5.5.1 Terminator

A single terminator is provided automatically on each segment whether one or two F80x Power Modules are used.

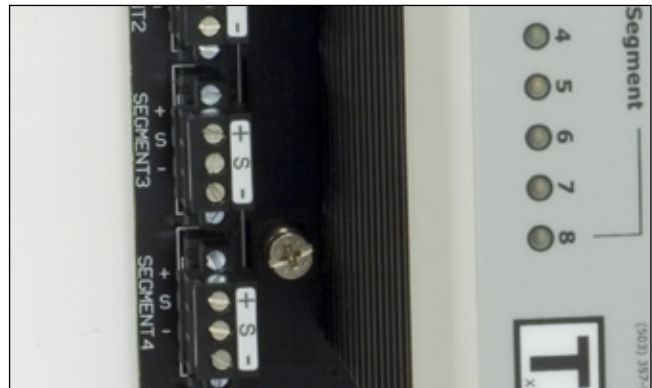

Figure 5.7 - Fieldbus segment connectors - screw terminal version

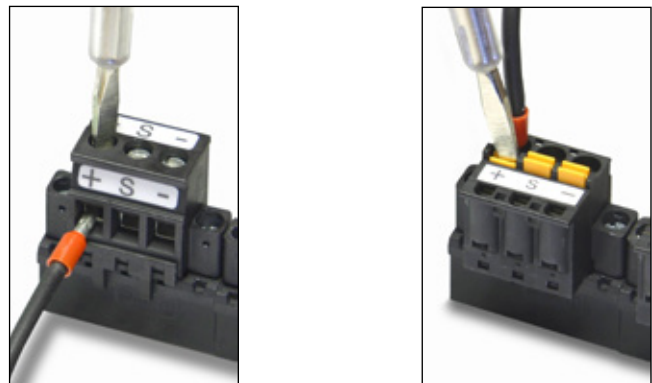

Figure 5.8 - Screw terminal and spring-clamp connectors

5.6 Grounding

5.6.1 Fieldbus ground

The 'S' terminals are connected via the baseplate to a Screen/Shield Ground terminal in the bottom left corner of the baseplate (see Figure 5.9). The Screen/Shield Ground terminal should be connected to a "clean" instrumentation ground.

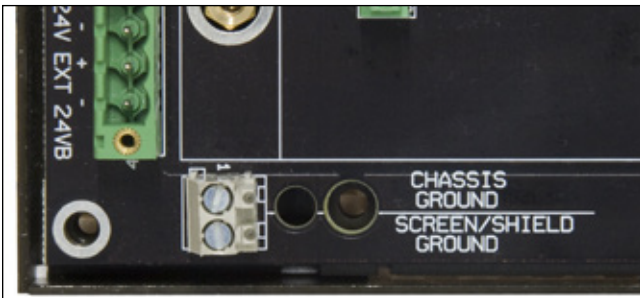

Figure 5.9 - Ground terminals

5.6.2 Chassis ground

A protective and EMC ground connection is available at the Chassis Ground terminal in the bottom left corner of the baseplate (see Figure 5.9). This is connected to the metal cases of the F80x power modules and the F809F diagnostic module and should be connected to the cabinet ground.

5.7 Diagnostics module

A Fieldbus Diagnostic Module, type F809F, can be fitted on the F810 baseplate. It may be assigned as a participant fieldbus device on segments 1 or 8 or, alternatively, it can communicate with the Foxboro I/A control system by means of a dedicated FOUNDATION fieldbus™ H1 segment. Refer to the separate instruction manual for the F809F (**INM F809F**) for further details.

Figure 5.10 shows how a dedicated diagnostic segment, comprising multiple F810 baseplates, is interlinked, powered and terminated. Where baseplates are installed in vertical columns, connect the H1+, H1- and H1S terminals of adjacent baseplates as shown. A segment may support a number of F809F modules. The actual number is based on a number of factors:

- the logical device limit of the host,
- the fieldbus power supply capacity,
- operational constraints such as bandwidth and
- the overall (system) impact of the loss of that diagnostic segment

It is recommended that shielded, twisted-pair cable, complying with FOUNDATION fieldbus™ 'Type A' construction shall be used.

5.7.1 Diagnostics module power supply

The diagnostic segment must be powered by a conditioned fieldbus power supply (see Figure 5.10), such that a voltage in the range 9–32V DC is available at each F809F fieldbus diagnostic module connected on the segment.

Note: This power is not provided automatically from the F810 baseplate and must be connected as shown in Figure 5.10

This power supply may be either simplex or redundant, depending on the application, and be capable of providing sufficient current for the entire diagnostic segment. Each F809F module draws approximately 15mA, so a segment comprising 10 modules will, for example, require an output current of at least 150mA. A suitable redundant fieldbus power supply is MTL type FPS-I, which provides 350mA at 25.0V DC. Alternatively, type FPS-DT provides two segments of non-redundant power.

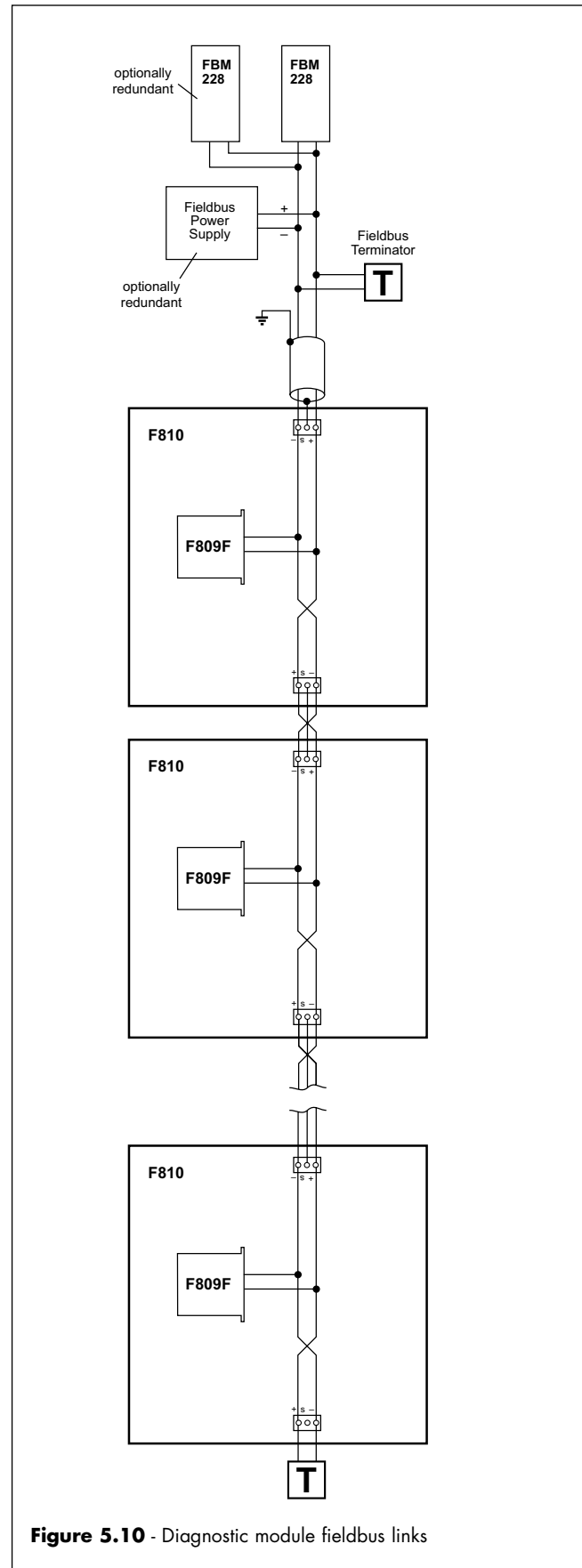

Figure 5.10 - Diagnostic module fieldbus links

5.7.2 Diagnostics module segment termination

The diagnostic segment must be terminated at both ends to maintain the bus impedance within FOUNDATION fieldbus™ limits. A terminator must therefore be connected between the H1+ and H1- terminals of the diagnostic bus connector at the far end of the segment (see Figure 5.10). A suitable terminator for this purpose is MTL type FBT1-IS. Termination of the bus at the opposite end may be provided by an integrated terminator within the power supply (such as exists within the FPS-I and FPS-DT types) or by means of a separate terminator.

5.8 Address switch settings

The address of the FBM228 Fieldbus Interface Modules is set using address switches S1 to S3, according to the following tables:

SW1	SW2	ID
ON	ON	0
ON	OFF	1
OFF	ON	2
OFF	OFF	3

SW3
POSN.
1 – 4 ON
5 – 8 OFF

Table 5.11 - Address switch tables

6 TESTING & TROUBLESHOOTING

The F810 circuit board has no discrete components fitted so testing is confined to the operation of the modules fitted to the backplate.

6.1 F80x Status and Alarm LEDs

Each F80x power module is fitted with nine LEDs, eight to indicate segment status and one to signify an Alarm condition. Use Figure 6.1 below to help identify error conditions. Note: The LEDs on the F802 power modules will operate in the same manner.

6.2 Testing after installation

Apply power and, by consulting Figure 6.1, ensure that the **Normal** condition applies to the power modules.

If redundant power supplies are being used, disconnect the incoming secondary power and check that Fault condition c) occurs. Replace the secondary power connector and remove the primary and the module LED displays should be the reverse of condition c), i.e. module A LED display will now look like module B's and B's will look like A.

If external bulk supplies are being used - as described in Section 5.2.2 - it might be useful to perform a similar procedure where Power A and Power B connectors are removed in turn and the module LED displays should perform in the same manner as that just described.

6.3 Troubleshooting

The power module LED displays shown in Figure 6.1 should be consulted for help in identifying problems occurring with power supply or segment faults.

7 MAINTENANCE

7.1 Routine maintenance

Check the general condition of the installation occasionally to make sure that no deterioration has occurred. At least every two years (and more frequently for particularly harsh environments) check:

- ◆ the condition of wire connection/terminations/screens.
- ◆ the dc output voltage on each of the four fieldbus segments is >21.5V for the F801 and >28V for the F802. This can be performed using a multimeter or a Relcom FBT-3/ FBT-6 fieldbus tester.
- ◆ that the segment LEDs on the F80x module(s) are functioning and the Alarm LED(s) is not lit.
- ◆ that the retaining screws are tight.
- ◆ that there are no signs of damage or corrosion.

Figure 6.1 - F80x LEDs troubleshooting

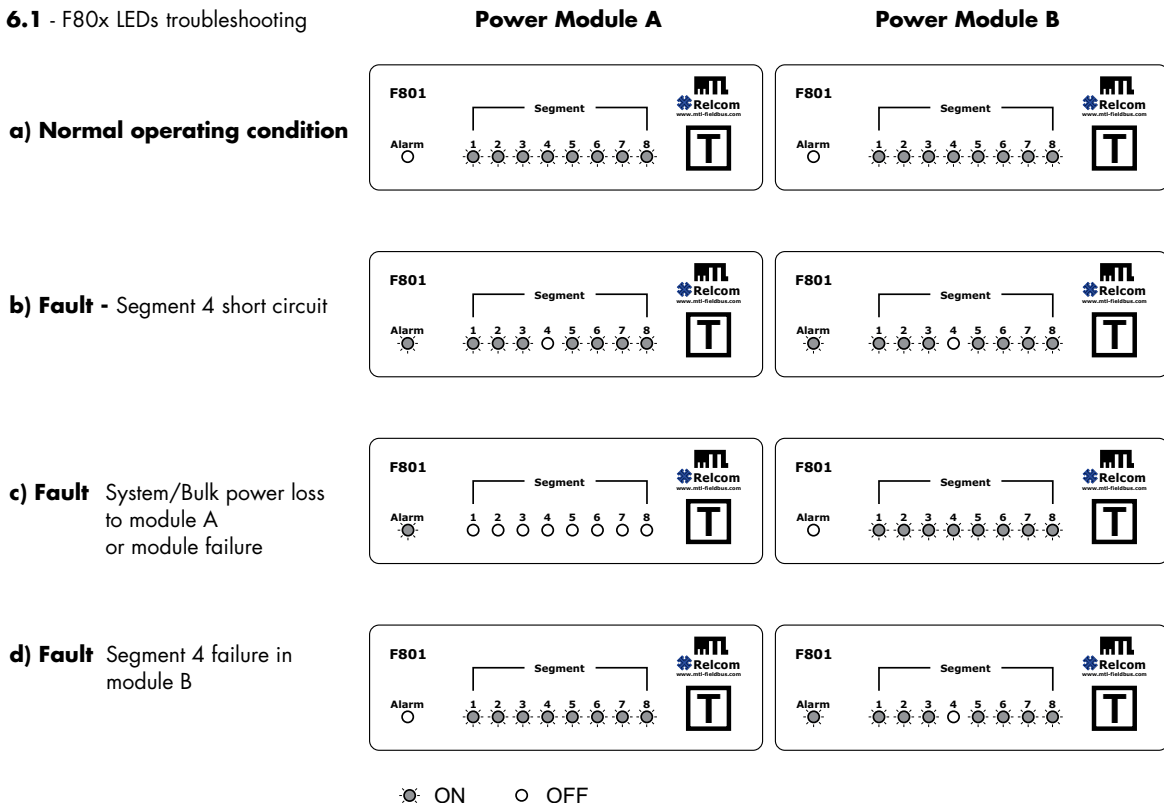

AUSTRALIA

MTL Instruments Pty Ltd,
10 Kent Road, Mascot, New South Wales, 2020, Australia
Tel: +61 1300 308 374 Fax: +61 1300 308 463
E-mail: mtl-salesanz@eaton.com

BeNeLux

MTL Instruments BV
Ambacht 6, 5301 KW Zaltbommel
The Netherlands
Tel: +31 (0)418 570290 Fax: +31 (0)418 541044
E-mail: mtl.benelux@eaton.com

CHINA

Cooper Electric (Shanghai) Co. Ltd
955 Shengli Road, Heqing Industrial Park
Pudong New Area, Shanghai 201201
Tel: +86 21 2899 3817 Fax: +86 21 2899 3992
E-mail: mtl-cn@eaton.com

FRANCE

MTL Instruments sarl,
7 rue des Rosiéristes, 69410 Champagne au Mont d'Or
France
Tel: +33 (0)4 37 46 16 53 Fax: +33 (0)4 37 46 17 20
E-mail: mtlfrance@eaton.com

GERMANY

MTL Instruments GmbH,
Heinrich-Hertz-Str. 12, 50170 Kerpen, Germany
Tel: +49 (0)22 73 98 12-0 Fax: +49 (0)22 73 98 12-2 00
E-mail: csckerpen@eaton.com

INDIA

MTL India,
No.36, Nehru Street, Off Old Mahabalipuram Road
Sholinganallur, Chennai- 600 119, India
Tel: +91 (0) 44 24501660 /24501857 Fax: +91 (0) 44 24501463
E-mail: mtlindiasales@eaton.com

ITALY

MTL Italia srl,
Via San Bovio, 3, 20090 Segrate, Milano, Italy
Tel: +39 02 959501 Fax: +39 02 95950759
E-mail: chmninfo@eaton.com

JAPAN

Cooper Crouse-Hinds Japan KK,
MT Building 3F, 2-7-5 Shiba Daimon, Minato-ku,
Tokyo, Japan 105-0012
Tel: +81 (0)3 6430 3128 Fax: +81 (0)3 6430 3129
E-mail: mtl-jp@eaton.com

NORWAY

Norex AS
Fekjan 7c, Postboks 147,
N-1378 Nesbru, Norway
Tel: +47 66 77 43 80 Fax: +47 66 84 55 33
E-mail: info@norex.no

RUSSIA

Cooper Industries Russia LLC
Elektrozavodskaya Str 33
Building 4
Moscow 107076, Russia
Tel: +7 (495) 981 3770 Fax: +7 (495) 981 3771
E-mail: mtlrussia@eaton.com

SINGAPORE

Cooper Crouse-Hinds Pte Ltd
No 2 Serangoon North Avenue 5, #06-01 Fu Yu Building
Singapore 554911
Tel: +65 6 645 9888 Fax: +65 6 487 7997
E-mail: sales.mtlsing@eaton.com

SOUTH KOREA

Cooper Crouse-Hinds Korea
7F, Parkland Building 237-11 Nonhyun-dong Gangnam-gu,
Seoul 135-546, South Korea.
Tel: +82 6380 4805 Fax: +82 6380 4839
E-mail: mtl-korea@eaton.com

UNITED ARAB EMIRATES

Cooper Industries/Eaton Corporation
Office 205/206, 2nd Floor SJ Towers, off. Old Airport Road,
Abu Dhabi, United Arab Emirates
Tel: +971 2 44 66 840 Fax: +971 2 44 66 841
E-mail: mtlgulf@eaton.com

UNITED KINGDOM

Eaton Electric Ltd,
Great Marlings, Butterfield, Luton
Beds LU2 8DL
Tel: +44 (0)1582 723633 Fax: +44 (0)1582 422283
E-mail: mtlenquiry@eaton.com

AMERICAS

Cooper Crouse-Hinds MTL Inc.
3413 N. Sam Houston Parkway W.
Suite 200, Houston TX 77086, USA
Tel: +1 281-571-8065 Fax: +1 281-571-8069
E-mail: mtl-us-info@eaton.com