

MTL4000 SERIES ACCESSORIES

MTL4000 MODULE ACCESSORIES

- CCH01** Hazardous-area crimp connector
- SCC01** Hazardous-area screw-clamp connector
- SCJ01** Hazardous-area screw-clamp connector with integral CJC sensor



- CRC01** Crimps 0.5-2.0mm² (20-14 AWG), pack of 100

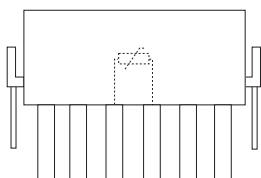

- CRC02** Crimps 0.2-0.8mm² (24-18 AWG), pack of 100
- CRT01** Crimp tool for 1.5-6.0mm² (15-9 AWG) wire
- CRT02** Crimp tool for 0.1-1.6mm² (27-15 AWG) wire
- CRRO1** Crimp removal tool for CRC01, CRC02 or power sense crimps

MTL4000 BACKPLANE ACCESSORIES

- ERK08** Earth rail kit for BPM/BPS08 backplanes
- ERK16** Earth rail kit for BPM/BPS16 backplanes
- TSK08** Tagging strip kit for BPM/BPS08 backplanes
- TSK16** Tagging strip kit for BPM/BPS16 backplanes
- TSK24** Tagging strip kit for BPM/BPS24 backplanes
- SMS01** Backplane surface mounting kit, pack of 40
- DMK01** Backplane DIN-rail mounting kit, G- or T-section, pack of 40

MTL BX08 ENCLOSURE

SPECIFICATIONS

BX08: for 1 x BPM08 or BPS08 backplane

Location

Safe area

Protection

Dust-tight and water-jet proof to IEC529:IP65

Ambient temperature limits

-20 to +60°C, depending upon modules fitted
(see instruction manual INM4000 for details)

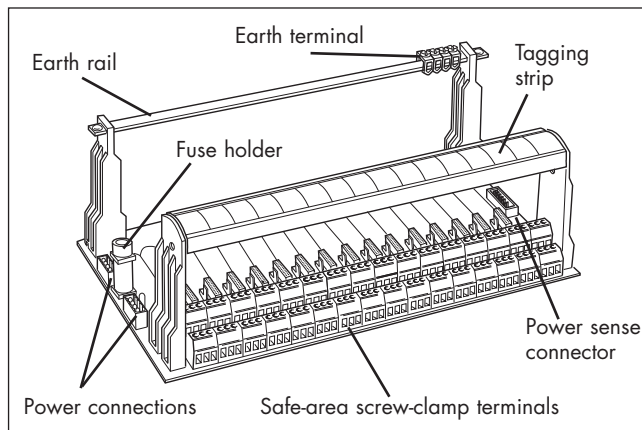

- BMK08** Mounting kit – surface/DIN-rail accessories for one 4- or 8-way backplane

- BMK16** Mounting kit – surface/DIN-rail accessories for one 16-way backplane

- HMP24** Horizontal mounting plate and screws for 19-inch rack, 24-way backplane only,

- ELC56** Elco 8016, 56-way cable plug kit

- FUS08** Fuse kit, BPM/BPS08 backplanes, pack of 10

- FUS16** Fuse kit, BPM/BPS16 backplanes, pack of 10

- FUS24** Fuse kit, BPM/BPS24 backplanes, pack of 10

- MPL01** Module position labels (blank), pack of 50

HMP24 Horizontal mounting plate for 19-inch rack, 24-way backplane only, (includes mounting screws)

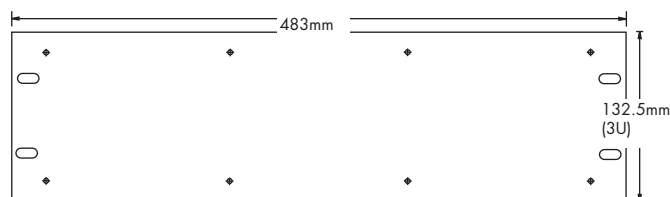

Maximum height from backplane to top of tagging strip: 92mm

Construction

Base: GRP (glass-fibre reinforced polyester)

Lid: transparent high-strength polycarbonate

Finish

Base: light grey

Lid: transparent

Lid fixing

Captive fixing screws

Gland fixing

Side mounted gland plate, detachable for drilling by user

Mounting

By exterior surface-fixing lugs (zinc-passivated steel)

Internal cable trunking

Provided on all enclosures

Backplane mounts

Necessary surface mounting kits (of screws, washers, spacers and retaining washers) are provided with the enclosure

Weight (without backplanes and units)

BX08: 3.7kg



EUROPE (EMEA)

AMERICAS

ASIA PACIFIC

E-mail: enquiry@mtl-inst.com

Tel: +44 (0)1582 723633

Tel: +1 603 926 0090

Tel: +65 6 487 7887

Web site: www.mtl-inst.com

Fax: +44 (0)1582 422283

Fax: +1 603 926 1899

Fax: +65 6 487 7997

June 2004

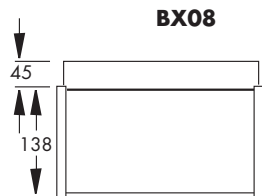
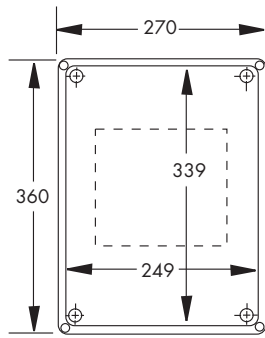

BX08

MTL4000 SERIES ORDERING INFORMATION



Intrinsically safe interface units

Specify module number

Module accessories

CCH01	Hazardous-area crimp connector
CRC01	Large crimps (100 per pack)
CRC02	Small crimps (100 per pack)
SCC01	Screw clamp connector
SCJ01	Hazardous-area screw clamp connector with integral CJC sensor (required for use with MTL4073 with THC inputs requiring CJC)
MPL01	Module position label (blank) (50 per pack)

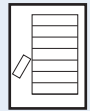

Backplanes

BPM08	8-way backplane multiway connector
BPM16	16-way backplane multiway connector
BPM24	24-way backplane multiway connector
BPS04	4-way backplane screw-clamp connector
BPS08	8-way backplane screw-clamp connector
BPS16	16-way backplane screw-clamp connector
BPS24	24-way backplane screw-clamp connector

Backplane mounting accessories

DMK01	DIN-rail mounting kit, T- or G-section (pack of 40) 8-way backplanes require 4 16-way backplanes require 6
SMS01	Surface mounting kit (pack of 40) 4 and 8-way backplanes require 4 16-way backplanes require 6 24-way backplanes require 8
HMP24	Horizontal mounting plate and screws for 19-inch rack mounting 24-way backplanes only
BMK08	Mounting kit for one 4- or 8-way backplane
BMK16	Mounting kit for one 16-way backplane

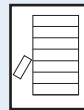

Backplane accessories

ERK08	Earth rail kit for 8-way backplanes BPM08 or BPS08
ERK16	Earth rail kit for 16-way backplanes BPM16 or BPS16
TSK08	Tagging strip kit for 8-way backplanes BPM08 or BPS08
TSK16	Tagging strip kit for 16-way backplanes BPM16 or BPS16
TSK24	Tagging strip kit for 24-way backplanes BPM24 or BPS24
ELC56	Elco 8016, 56-way cable plug kit for use with BPM style backplanes 1 required per 8 modules
FUS08	Fuse kit for 4 and 8-way backplanes (10 per pack)
FUS16	Fuse kit for 16-way backplane (10 per pack)
FUS24	Fuse kit for 24-way backplanes (10 per pack)

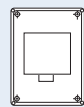

Enclosures

BX08	8-way enclosure suitable for 1 BPM08, BPS04 or BPS08
------	--



General Accessories

CRT01	Crimp tool
CRT02	Crimp tool
CRR01	Crimp removal tool for CRC01, CRC02, and power sense crimps

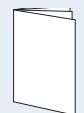

Literature

INM4000	MTL4000 Series instruction manual
AN9013	MTL4000 Series application note

