

# MTL831C

## Analog Transmitter

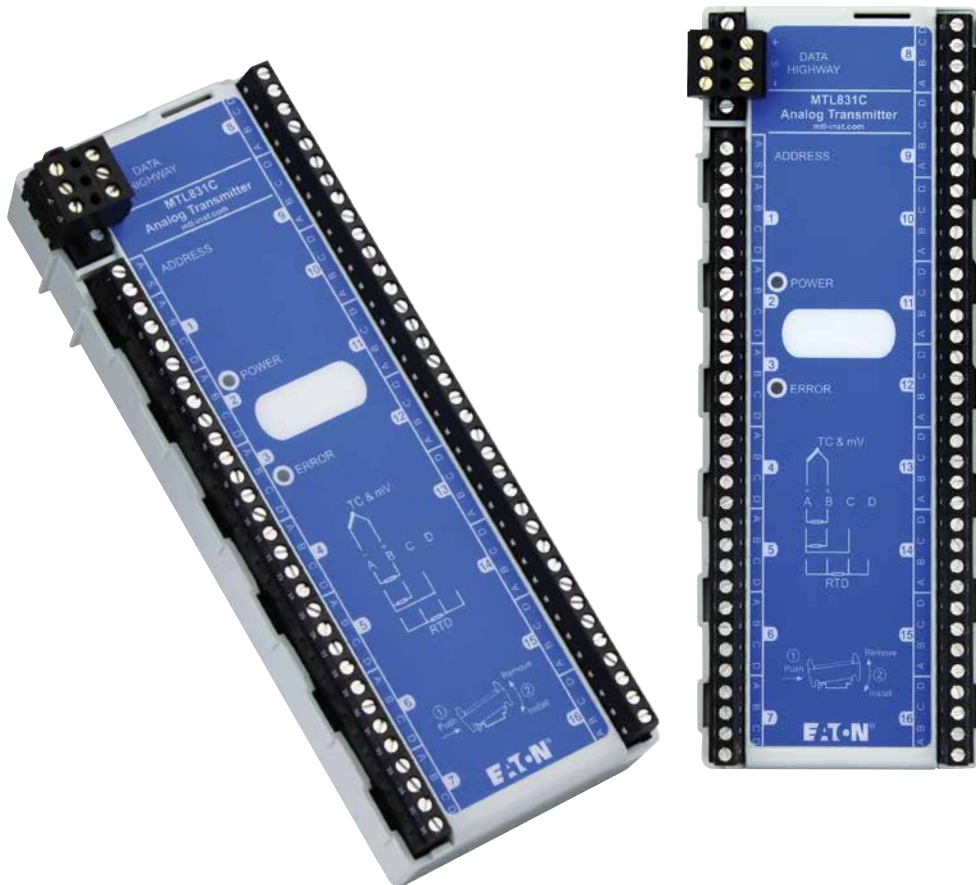

## **DECLARATION OF CONFORMITY**

A printed version of the Declaration of Conformity has been provided separately within the original shipment of goods. However, you can find a copy of the latest version at -

<http://www.mtl-inst.com/certificates>

# CONTENTS

	<b>DECLARATION OF CONFORMITY</b> .....	<b>ii</b>
	<b>GENERAL SAFETY INFORMATION</b> .....	<b>iv</b>
<b>1</b>	<b>ABOUT THIS MANUAL</b> .....	<b>1</b>
1.1	Related documents .....	1
1.2	Product description .....	2
<b>2</b>	<b>GETTING STARTED</b> .....	<b>2</b>
<b>3</b>	<b>COMPONENTS AND ACCESSORIES</b> .....	<b>3</b>
<b>4</b>	<b>MECHANICAL INSTALLATION</b> .....	<b>3</b>
4.1	Location .....	3
4.2	Mounting options .....	3
4.2.1	Mounting on T-section DIN-rail .....	3
<b>5</b>	<b>CONNECTIONS</b> .....	<b>4</b>
5.1	Address .....	4
5.2	Electrical connections .....	5
5.3	Sensor inputs .....	5
5.4	RTD inputs .....	5
5.5	THCs and mV inputs .....	5
5.6	THC Burnout Detection .....	6
5.7	Mixed Inputs .....	6
5.8	Data highway .....	6
5.9	Transmission distances .....	6
5.10	IS applications .....	6
5.11	Multi-transmitter connections .....	7
5.12	Cable screens .....	7
<b>6</b>	<b>ROUTINE MAINTENANCE</b> .....	<b>8</b>
<b>7</b>	<b>CONFIGURATION</b> .....	<b>8</b>
7.1	Sensor mode setting .....	8
<b>8</b>	<b>LED INDICATORS</b> .....	<b>8</b>
8.1	Power up .....	8
8.2	Firmware Update .....	9
<b>9</b>	<b>START UP AND INFREQUENT MEASUREMENTS</b> .....	<b>9</b>
<b>10</b>	<b>FAULT-FINDING IN THE MTL831C</b> .....	<b>10/11</b>
<b>11</b>	<b>ATEX and IECEx INFORMATION</b> .....	<b>12/13</b>
<b>12</b>	<b>APPENDIX A</b> .....	<b>14</b>
12.1	ATEX and IECEx Control drawing for MTL831C analog transmitters .....	14
<b>13</b>	<b>APPENDIX B</b> .....	<b>15</b>
13.1	Maintenance .....	15
13.2	Disposal .....	15

## GENERAL SAFETY INFORMATION

The following methods are used in this manual to alert the user to important information:-



**WARNING !**  
**Warnings are provided to ensure operator safety and MUST be followed.**

### CAUTION

Cautions are provided to prevent damage to the instrument.

### NOTE

These are used to give general information to ensure correct operation.

## SAFETY INSTRUCTIONS FOR INSTALLATION AND OPERATING PERSONNEL

The operating instructions provided here contain **essential safety instructions** for installation personnel and those engaged in the operation, maintenance and servicing of the equipment.



**WARNING !**  
**Failure to comply with these instructions can endanger the lives or health of personnel and risk damage to the plant and the environment.**



**WARNING !**  
**The responsibility for planning, installation, commissioning, operation and maintenance, particularly with respect to applications in explosion-hazard areas, lies with the plant operator.**

### Before commencing installation or commissioning:

- Read and understand the contents of this manual and the product datasheet
- Ensure installation and operating personnel have received adequate training for this task
- Ensure that any operating instructions are fully understood by the personnel responsible.
- Observe national and local installation and mounting regulations (e.g. IEC 60079-14).



**WARNING !**  
**If these assemblies have been used previously in general electrical installations, they MAY NOT be used in explosion-hazard area applications.**

### During operation:

- Make the relevant instructions available at all times to the operating personnel.
- Observe safety instructions.
- Observe national safety and accident prevention regulations.
- Operate the equipment within its published specification.
- Servicing, maintenance work or repairs not described in this manual must not be performed without prior agreement with the manufacturer.
- Any damage to this equipment may render its explosion protection null and void.
- No changes to any of the components that might impair their explosion protection are permitted.

### If any information provided here is not clear:

- Contact Eaton's MTL product line support or one of its representatives.

### NOTE

Improper installation and operation of the enclosure can result in the invalidation of the warranty.

# MTL831C

## Analog Transmitter



**Figure 1.1** - MTL831C Analog Transmitter

### CAUTIONARY NOTE:

In common with all other electrical apparatus installed in hazardous areas, this apparatus must only be installed, operated and maintained by competent personnel. Such personnel shall have undergone training, which included instruction on the various types of protection and installation practices, the relevant rules and regulations, and on the general principles of area classification. Appropriate refresher training shall be given on a regular basis. [See clause 4.2 of EN 60079-17]. This instruction manual supplements the requirements of nationally accepted codes of practice, for example, IEC/EN 60079-14 in Europe. All installations should comply with the relevant sections of these codes.

In addition, particular industries or end users may have specific requirements relating to the safety of their installations, and these requirements should also be met.

## 1 ABOUT THIS MANUAL

The purpose of this manual is to provide the user with information on the installation, connection and configuration of the MTL831C Analog Transmitter.

### 1.1 Related documents

This manual does NOT cover the connection or configuration of the MTL838C receiver. For details of these items consult:

- **INM MTL838C** Receiver Instruction Manual

For IS installations the **MTL5553/MTL5053** Isolator/power supply will be required. For details of these items consult:

- **INM MTL5500** range manual (MTL5553)
- **INM MTL5000** range manual (MTL5053)

Other related manuals:

- **EPS MTL830C** Temperature Multiplexer system datasheet
- **INM MTL838C-MBF** Modbus implementation manual
- **INM MTL83xC LLMUX** PC SW Manual- LLMUX
- **INM MTL83xC Modbus** PC SW Manual- Modbus
- **TSN MTL838C Modbus** Introduction to Modbus support notes

## 1.2 Product description

The MTL831C Analog Transmitter can transfer a number of hazardous area input signals to the safe area down a data highway consisting of a single shielded, twisted-pair cable. It is intrinsically safe and can therefore be mounted in Zone 0 hazardous areas or hazardous locations.

The MTL831C can monitor up to 16 inputs from THC or millivolt sources or 2, 3 or 4-wire RTDs or potentiometers.

A data highway is provided that can carry both signal and power over distances up to 2km, depending on the application, the cable and the (noise) environment. Shielded twisted pair is highly recommended.

At the other end of the data highway, an MTL838C Receiver translates the information transmitted from the MTL831C. One or two MTL831Cs may be connected to a single MTL838C. The MTL838C provides a \*Modbus® serial data output representation of the inputs together with status information.

When the MTL831C transmitter is mounted in the hazardous area, the data highway must be protected by an MTL5553/MTL5053 Isolator/Power Supply mounted in the safe area.

*\* Modbus® is a registered trademark of Schneider Automation Inc.*

## 2 GETTING STARTED

Installation of the MTL831C multiplexer transmitter is divided into three main topics.

- **Mechanical Installation** - how to mount the MTL831C and how it may be fitted into an enclosure.
- **Electrical Connections** - the sensor and highway connections. If units are installed in our enclosures, it details any special wiring arrangements.
- **Configuration** - the address is configured with a user supplied jumper wire. The remaining configuration is either over a Modbus® link or software on a PC.

### NOTE

A new user might find it helpful to set up the system, or a simple version of it, in an indoor test area to gain familiarisation before undertaking installation on site.

### 3 COMPONENTS AND ACCESSORIES

Product part numbers and their descriptions are listed below.

Part Number	Description
MTL831C	Analog Transmitter
MTL838C	Receiver
MTL5553/MTL5053	Isolator/Power Supply

A standard USB Type C cable (not supplied by Eaton) is required to configure the MTL838C

### 4 MECHANICAL INSTALLATION

#### 4.1 Location

The MTL831C can be installed in either safe or hazardous areas (including Zone 0) depending upon the requirements of the application.

#### 4.2 Mounting options

The unit can be mounted on T-section DIN-rail. Eaton has a range of enclosures - ENC8, ENC8-SS, ENC83 or ENC83-SS- to provide suitable IP67 protection if the transmitter is located in an exposed area.

##### 4.2.1 Mounting on T-section DIN-rail

To install, tilt the MTL831C to the left and hook to the left side of the standard 35mm DIN46277 T-section rail. Push to the right and allow the unit to rotate down to sit flat on the DIN Rail. Allow it to spring back to the left and the right side will hook to the DIN Rail.

To remove, push the MTL831C to the right and tilt the right side away from the DIN Rail. While tilted, allow it to spring back to the left and remove from the DIN Rail.

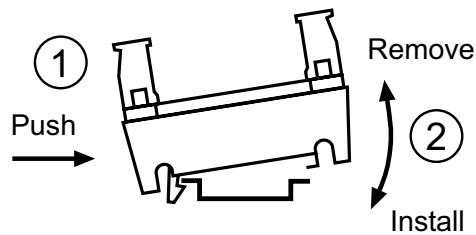

## 5 CONNECTIONS

The connection terminals are along the edges of the Analog Transmitter. These are divided into input sensor terminals (1 to 16), the Address terminals (A, S), and the data highway terminals (+, S, -), as shown below.

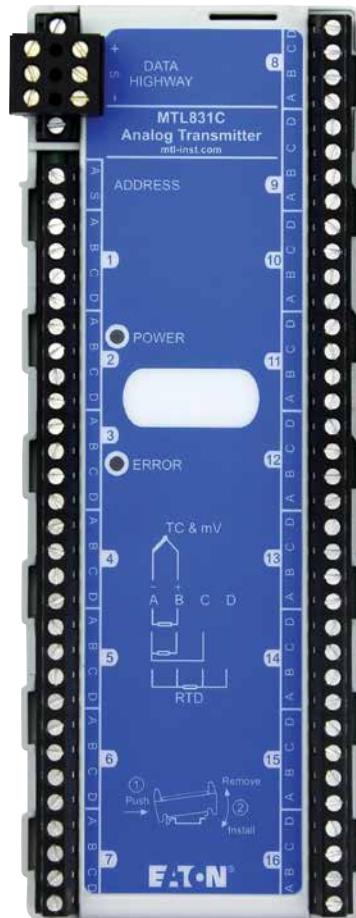

### 5.1 Address

Leaving these two pins (A, S) open, sets the address of the MTL831C to "1". A jumper on these two pins sets the address to "2". Either is valid for a system with only one MTL831C connected to the MTL838C. When two MTL831Cs are connected to a single MTL838C, they must be addressed uniquely. If they are on the same address, only one will communicate with the MTL838C. The address affects where the data is seen in the PC Software and what is available on the RS485 ports:

ADDRESS	PC Software	Modbus Port A or B	LLMUX Emulation
1	MTL831C #1 tab	Channels 1-16	Link 1, channels 1-16
2	MTL831C #2 tab	Channels 17-32	Link 2, channels 1-16



## 5.2 Electrical connections

The data highway connector is pluggable (with securing screws) and has standard screw-terminals for connecting wiring.

Type	Conductor size
Trunk screw terminals	0.14 to 2.5mm <sup>2</sup>
Sensor input screw terminals	0.14 to 1.4mm <sup>2</sup>

### NOTE

A *torque screwdriver* set between 0.5 - 0.6Nm is recommended for tightening all terminal screws.



**Screw Terminal**

## 5.3 Sensor inputs

Sensors connected to the MTL831C should not be earthed. This avoids differences in earth potential that could affect measurement accuracy or damage the MTL831C. If sensors must be earthed they should be located close to each other to avoid differences in earth potential.

## 5.4 RTD inputs

The 16 channels can be configured for 2, 3 or 4 wire mode as shown in the connection diagram on the unit overlay. Software configuration is also required to select the proper measuring method. This is done via PC Software or Modbus. By default the MTL831C is configured for mV inputs.

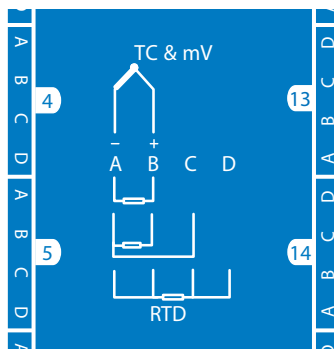

## 5.5 THCs and mV inputs

Connect up to 16 THC or mV inputs directly to the input terminals as shown on the overlay connection diagram making sure the polarity is correct.

## 5.6 THC Burnout Detection

The MTL838C/MTL831C system provides for thermocouple burnout detection. This is implemented by periodically measuring the resistance of the thermocouple and comparing it to the initial measurement. If the resistance increases by more than 50 ohms, a warning is available in the sensor status (readings are still available). For more information, see the instructions for the MTL838C Receiver. The following are events that lock in the initial resistance measurement:

- The MTL831C is powered up (initial resistance measurement is locked in after 30 seconds).
- A Channel configured as a THC goes open for at least 1.3 second and then closed (this is intended to reset the initial value when the THC is replaced).
- A Channel that was not configured as a THC is changed to a THC. This configuration change would come from the PC software or Modbus.

## 5.7 Mixed Inputs

It is possible to mix any combination of different input sensor types on the 16 input channels.

Connect the different sensors appropriately, as shown in the connection diagram on the unit overlay.

## 5.8 Data highway

The data highway connection is also the source of DC power for the MTL831C. It is important that the polarity of the wiring on the "+" and "-" terminals is correct. A shielded twisted-pair wire is recommended. The "S" terminal is wired to the cable shield. It is not internally connected in the MTL831C.

## 5.9 Transmission distances

The maximum data highway length will depend upon two key factors: the type and quality of the cable used, and the level of electrical interference present in the environment.

Typically a user might expect: IS applications- 1km

Non-IS applications- 2km.

The reduced distance for IS applications is due to the voltage drop from the current limiting resistor in the MTL5553/MTL5053 IS isolator and may also be limited by the inductance and capacitance of the data highway cable that is required for the IS cable parameter calculations. (See IEC/EN 60079-14 for further details).

We recommend using 16 gauge Foundation Fieldbus cable that has been checkmarked as meeting the FF standard for data highway cables. This will help ensure that the maximum lengths can be achieved with successful communication in the presence of noise.

Also, do not run the data highway cable near or in parallel with high voltage lines, VFDs, or motors driven with a VFD as these can create noise that would interfere with communication.

## 5.10 IS applications

For IS applications, the data highway connection must be via a galvanic isolator and so an MTL5553/MTL5053 isolator is connected in-line in the safe area (see Figure x).

The - and + terminals of the data highway should be connected to the corresponding -ve and +ve terminals of the MTL5553/MTL5053 (13 & 14 respectively) located in the safe area. See the section on ATEX and IECEx information for detailed instructions.

### 5.11 Multi-transmitter connections

Connect the data highway to a receiver for MTL831C Transmitter #1 as in diagram below. Connect the MTL831C Transmitter #1 data highway (+, S, and – terminal) to the equivalent terminals on a MTL831C Transmitter #2. Install a jumper wire between the Address terminals (A and S) on MTL831C Transmitter #2.

#### NOTE

The MTL831C is supplied with a double sided data highway connector to facilitate linking two MTL831C Transmitters.

Up to two MTL831C Analog Transmitters may be connected on a single data highway to the MTL838C/MTL5553 or MTL5053

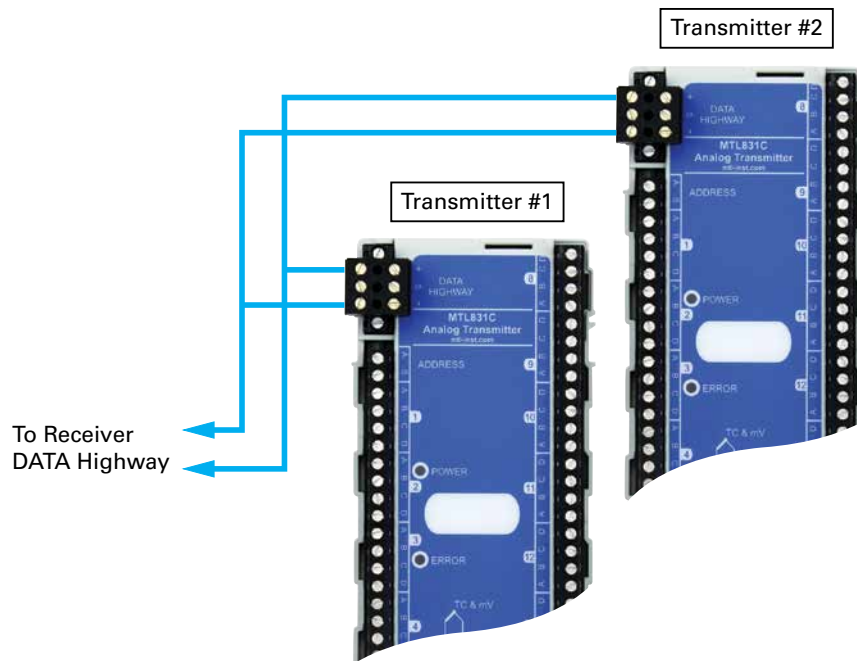

### 5.12 Cable screens

Cables screens should be earthed in only one location. Generally screens of sensor cables are earthed at the temperature multiplexer - MTL831C. If a sensor cable is earthed at the sensor, then it should not be earthed or connected to other screens at the MTL831C.

The screen of a data highway cable between the MTL831C transmitter and MTL5553/ MTL5053 isolator for IS applications or direct to MTL838C for non-IS applications, is either connected to an earth rail in the MTL831C's field enclosure or earthed in the control room.

## 6 ROUTINE MAINTENANCE

Check the general condition of the installation periodically to make sure that no deterioration has occurred. At least every two years (and more frequently for particularly harsh environments) check that:

- cable, wire connections, terminations, and screens are in good condition
- the green POWER LED is blinking
- the red ERROR LED is not lit
- no signs of damage or corrosion are present

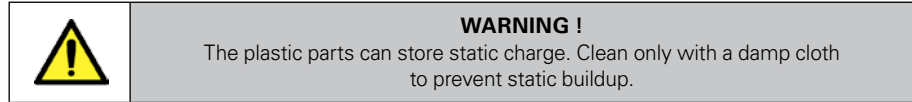

## 7 CONFIGURATION

The only hardware configuration is the setting of the unit's address – see section 4.1. The remaining configuration comes from the MTL838C.

### 7.1 Sensor configuration

All sensor configurations are done through the MTL838C PC software or via Modbus. Note that the configuration data is actually held in the MTL838C for one or two MTL831C Transmitters – depending on how many are connected. If an MTL831C must be replaced for some reason, its configuration is automatically transmitted from the MTL838C to the MTL831C when it is powered up. See the PC software or Modbus manuals for information on configuring sensors.

## 8 LED INDICATORS

There are 2 LEDs to indicate the health and status of the unit. The following are their meanings:

**POWER:** When illuminated (green), this indicates that power is available to the unit. When it blinks it means that at least one good packet was received from the MTL838C in the last 1/4sec. This LED should normally be blinking.

**ERROR:** Red illumination means that there was a CRC error in a packet received from the MTL838C. This LED goes off after 1/4sec without an error. The more it is on the more errored packets are being received.

### 8.1 Power up

When the unit first powers up, both LEDs come on for about 1 second and then go off. The POWER LED should then come back on. It is normal for the red LED to blink once or twice during the first 10 seconds or so after applying power.

## **8.2 Firmware Update**

During the first phase of the Firmware update which is initiated from the PC software, the POWER and ERROR LEDs alternately blink. When the first processor is updated, the unit restarts. During the remaining update process for the other two processors, the POWER LED either blinks normally or is on steady while the internal update process is taking place. The PC software provides status information during the update process.

## **9 START UP AND INFREQUENT MEASUREMENTS**

The MTL831C enters a startup process after power is applied. Normal operation begins about 60 seconds after power is applied. Thermocouple resistances (for burnout detection) and CJC (Cold Junction Compensation) temperatures are being measured frequently during startup. Afterwards these measurements are made infrequently (on the order of minutes). See section 4.5 for information on Thermocouple Burnout Detection.

## 10 FAULT-FINDING IN THE MTL831C

The following are some tips when the system does not seem to be functioning correctly. If you are still unable to solve the issue, please contact Eaton Technical Support for help.

### The POWER light is not ON or blinking

- There is not adequate power for the unit to function. Using a Voltmeter, measure the voltage at the data highway “+” and “-” terminals and verify that it meets the minimum voltage specification. A margin of at least 1 volt over the minimum is recommended.
- The unit is faulty. Please contact Eaton for further assistance.

### The COMM light comes on and does not blink

- Two MTL831Cs are at the same address. If there is more than one MTL831C (there should never be more than 2), one and only one of them should have a jumper wire between the two ADDRESS pins (A, S). When two MTL831Cs are at the same address whichever one powers up first will be communicating with the MTL838C. The other unit recognizes its address already being used and remains idle.
- No communication signal is getting to the MTL831C. There can be multiple reasons for this:
  - In an IS installation, power for the MTL831C is coming from the MTL5553/MTL5053. If the MTL838C is not powered or not connected properly no signal will get to the MTL5553/MTL5053 to be passed to the MTL831C is.
  - For non-IS installations, power comes from the MTL838C, so it is possible the MTL838C has stopped communicating. Investigate by connecting to the MTL838C with a USB cable, PC, and the PC Software. It may be necessary to repower the MTL838C.
  - The MTL831C has stopped receiving communication. Try disconnecting it and reconnecting it to reboot it. The data highway cable is too noisy for the MTL831C to communicate with the MTL838C. Inspect the data highway cable run and make sure it is not near power cables, VFDs, VFD controllers, or other high current noise producing cables and equipment.
- The unit is faulty. Please contact Eaton for further assistance.

### The ERROR light comes on periodically

- The light flashes regularly every one or two seconds. If this persists, you may see the unit reboot – see section 6.1. Power cycle the unit by disconnecting and reconnecting the data highway cable if this happens and keeps recurring. The failure of a firmware update process which would have been initiated from the PC software could also cause this. The solution would be to try the firmware update process again. If that fails to remedy the issue, the unit could be faulty. Contact Eaton for assistance.
- The light flashes randomly or often. This is likely a CRC error on packet receipt (bad packet). The following are the potential causes:
  - Extreme noise source is affecting the data highway cable. This could include VFDs, welders, etc.
  - Check all wiring terminations to see that they are tight and there are no unintended shorts.
  - Verify that the data highway shield is earthed at one location only.
  - Verify the integrity of the data highway cable.

- Use the PC software to check the diagnostic information.
- Try rebooting each device connected to the data highway one at a time.
- Contact Eaton for assistance if the source of the issue cannot be found.

**The POWER and ERROR lights alternately turn on and off**

- This is an indication that the unit is being updated with new firmware. If a firmware update fails to complete properly, the unit can get stuck in this mode. Perform the firmware update again. If this does not fix the issue, contact Eaton for assistance.

## 11 ATEX and IECEx Information

### MTL831C Analog Transmitter Ex Safety Instructions (503-215 Rev A.0)

The following information is in accordance with the Essential Health and Safety Requirements (Annex II) of the EU Directive 2014/34/EU [the ATEX Directive- safety of apparatus] and is provided for those locations where the ATEX Directive is applicable.

The following information is also provided for safe product use in accordance with IECEx standards.

#### General

- a) In common with all other electrical apparatus installed in hazardous areas, this apparatus must only be installed, operated and maintained by competent personnel. Such personnel shall have undergone training, which included instruction on the various types of protection and installation practices, the relevant rules and regulations, and on the general principles of area classification. Appropriate refresher training shall be given on a regular basis. [See clause 4.2 of EN 60079-17].
- b) This apparatus meets the requirements of electrical apparatus in accordance with IEC/EN 60079-0 and IEC/EN 60079-11.
- c) This apparatus provides protection against all the relevant additional hazards referred to in Annex II of the ATEX directive, such as those in clause 1.2.7.
- d) This apparatus satisfies the dielectric strength requirements of IEC/EN 60079-11 clause 6.3.13.

#### Installation

- a) The installation must comply with the appropriate European, national and local regulations, which may include reference to the IEC code of practice IEC 60079-14. In addition, particular industries or end users may have specific requirements relating to the safety of their installations and these requirements should also be met. For European installations the Directive 2014/34/EU [the ATEX Directive- safety of installations] is also applicable.
- b) This apparatus must not be subjected to mechanical and thermal stresses in excess of those permitted in the certification documentation, this document and the product specification.
- c) The apparatus must not be installed in a position where it may be attacked by aggressive substances and must be protected from excessive dust, moisture and other contaminants.
- d) If necessary in the end use application, the product must be installed in an enclosure to protect it from excessive dust, moisture, and mechanical damage.
- e) Mount on 7.5mm x 35mm 'top hat' DIN Rail according to the instructions on the device cover. Use of DIN Rail end stops is recommended for vertical DIN Rail installations.
- f) Connect per the Control Drawing provided in this document.



### **Inspection and maintenance**

- a) Inspection and maintenance should be carried out in accordance with European, national and local regulations which may refer to the IEC standard IEC 60079-17. In addition, specific industries or end users may have specific requirements which should also be met.
- b) Access to the internal circuitry must not be made during operation or at any other time.
- c) If the outer enclosure of the apparatus needs to be cleaned, this should be done with a cloth lightly moistened by a dilute mixture of detergent in water.

### **Repair**

This product must not be repaired. It must be replaced by an equivalent certified product.

### **Marking**

Each MTL831C is marked with the following information:

#### **IECEX**

- a) Company Name, and Address – Relcom Inc. Forest Grove, OR USA
- b) Product Type Identification – MTL831C
- c) Certificate number – IECEX ETL 18.0030 X
- d) Ex classification – Ex ia IIC T4 Ga
- e) Ambient Temperature range-- $-40C \leq T_{amb} \leq 70C$

#### **ATEX**

- a) Company Name, and Address – Relcom Inc. Forest Grove, OR USA
- b) Product Type Identification – MTL831C
- c) Certificate number – ITS18ATEX23750 X
- d) Ex classification – II 1 G Ex ia IIC T4 Ga
- e) CE mark and Notified Body Number – 0359
- f) Ambient Temperature range-- $-40C \leq T_{amb} \leq 70C$

### **Special Conditions for Safe Use**

- a) The equipment is housed within a plastic enclosure. Suitable precautions must be made to avoid rubbing or cleaning with solvents.

## 12 APPENDIX A

### 12.1 ATEX and IECEx Control Drawing for MTL831C Analog Transmitters

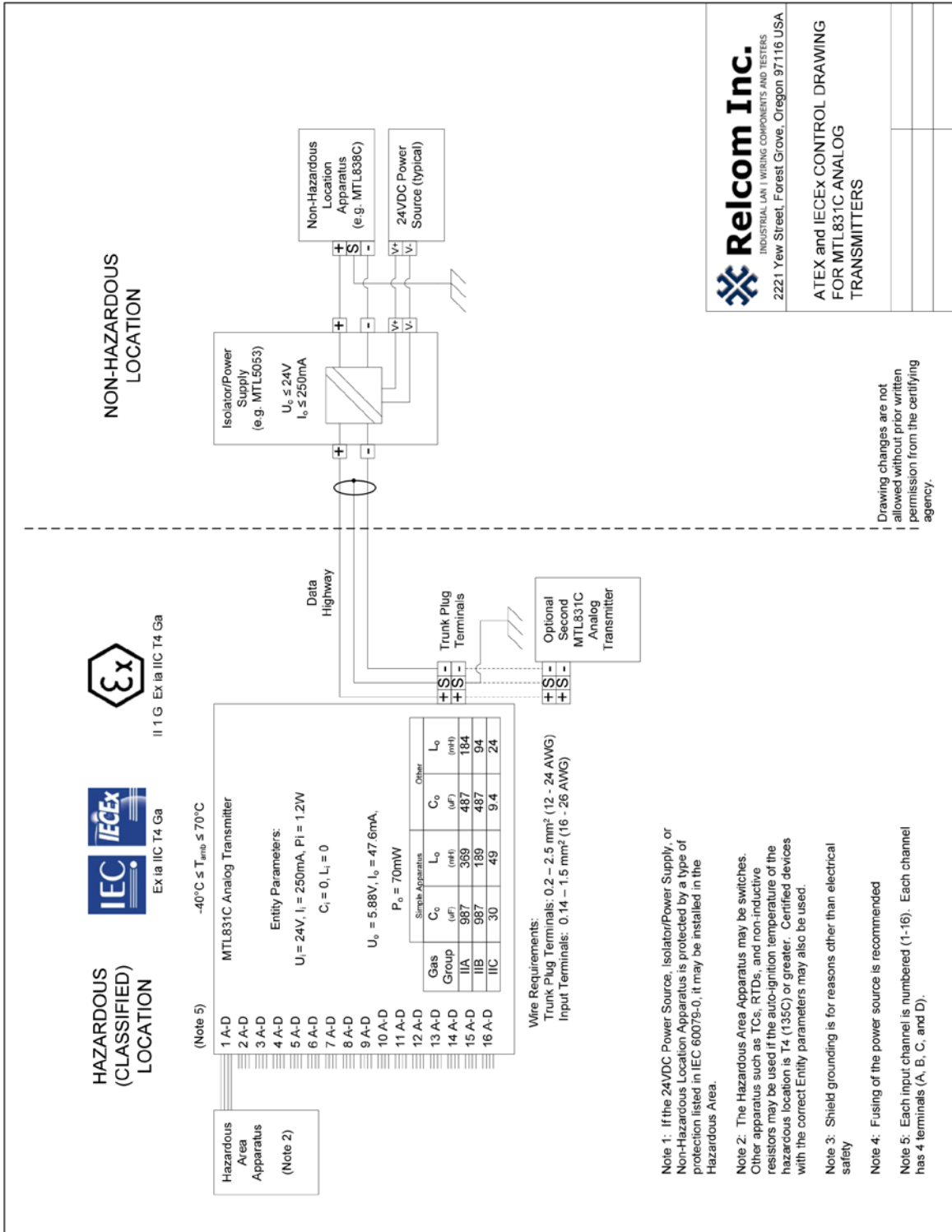

## 13 APPENDIX B

### 13.1 Maintenance

It is advisable to check the general condition of the installation from time to time to make sure no deterioration has occurred, and that no unauthorized modifications have been made. The following should be checked at intervals of not more than two years, and more frequently for systems used in particularly harsh environments.

Check that .....

- a. units are of the types specified in the relevant documentation.
- b. unit labelling and tagging is clearly legible, and the details given comply with the relevant documentation.
- c. units and enclosures are securely mounted.
- d. there are no signs of damage or corrosion affecting the installation.
- e. interconnecting cables are of the specified type and ratings, correctly routed and segregated, and not frayed or otherwise damaged.
- f. all connections are properly made.
- g. the locations in which the units are mounted have not been degraded by the introduction of harmful materials.
- h. access lids and doors to protective enclosures and cabinets are correctly secured.

### 13.2 Disposal

#### Product - End of Life

Eaton's MTL product line sells products world-wide that must meet the environmental and regulatory requirements of different countries and regions.

European directives on Waste Electronic and Electronic Equipment (WEEE) define the requirements on a producer to provide for the end-of-life recovery and recycling of electronic products when they become waste at the end of their life.



Eaton's MTL831C is marked with the 'crossed out wheelevator bin' symbol which indicates that the item is electronic or electronic equipment, and must be disposed of in the appropriate manner.

Other countries and regions may have their own environmental regulatory requirements regarding recovery and recycling of electronic products at the end of their life.

For more detailed information about take-back and equipment recycling please contact your local Eaton MTL representative.

## AUSTRALIA

MTL Instruments Pty Ltd,  
10 Kent Road, Mascot, New South Wales, 2020, Australia  
Tel: +61 1300 308 374 Fax: +61 1300 308 463  
E-mail: mtl-salesanz@eaton.com

## BeNeLux

MTL Instruments BV  
Ambacht 6, 5301 KW Zaltbommel  
The Netherlands  
Tel: +31 (0) 418 570290 Fax: +31 (0) 418 541044  
E-mail: mtl.benelux@eaton.com

## CHINA

Cooper Electric (Shanghai) Co. Ltd  
955 Shengli Road, Heqing Industrial Park  
Pudong New Area, Shanghai 201201  
Tel: +86 21 2899 3817 Fax: +86 21 2899 3992  
E-mail: mtl-cn@eaton.com

## FRANCE

MTL Instruments sarl,  
7 rue des Rosiéristes, 69410 Champagne au Mont d'Or  
France  
Tel: +33 (0)4 37 46 16 53 Fax: +33 (0)4 37 46 17 20  
E-mail: mtlfrance@eaton.com

## GERMANY

MTL Instruments GmbH,  
Heinrich-Hertz-Str. 12, 50170 Kerpen, Germany  
Tel: +49 (0)22 73 98 12-0 Fax: +49 (0)22 73 98 12-2 00  
E-mail: csckerpen@eaton.com

## INDIA

MTL India,  
No.36, Nehru Street, Off Old Mahabalipuram Road  
Sholinganallur, Chennai- 600 119, India  
Tel: +91 (0) 44 24501660 /24501857 Fax: +91 (0) 44 24501463  
E-mail: mtlindiasales@eaton.com

## ITALY

MTL Italia srl,  
Via San Bovio, 3, 20090 Segrate, Milano, Italy  
Tel: +39 02 959501 Fax: +39 02 95950759  
E-mail: chmninfo@eaton.com

## JAPAN

Cooper Industries Japan K.K.  
Unizo Nogizaka Bldg. 7th Floor, 8-11-37, Akasaka, Minato-ku,  
Tokyo, Japan 107-0052  
Tel: +81 (0)3 6434 7890 Fax: +81 (0)3 6434 7889  
E-mail: mtl-jp@eaton.com

## NORWAY

Norex AS  
Fekjan 7c, Postboks 147,  
N-1378 Nesbru, Norway  
Tel: +47 66 77 43 80 Fax: +47 66 84 55 33  
E-mail: info@norex.no

## RUSSIA

Cooper Industries Russia LLC  
Elektrozavodskaya Str 33  
Building 4  
Moscow 107076, Russia  
Tel: +7 (495) 981 3770 Fax: +7 (495) 981 3771  
E-mail: mtlrussia@eaton.com

## SINGAPORE

Cooper Crouse-Hinds Pte Ltd  
100G Pasir Panjang Road, Interlocal Centre  
#07-08 Singapore 118523  
Tel: +65 6645 9888 Fax: +65 6645 9811  
E-mail: sales.mtlsing@eaton.com

## SOUTH KOREA

Cooper Crouse-Hinds Korea  
7F, Parkland Building 237-11 Nonhyun-dong Gangnam-gu,  
Seoul 135-546, South Korea.  
Tel: +82 6380 4805 Fax: +82 6380 4839  
E-mail: mtl-korea@eaton.com

## UNITED ARAB EMIRATES

Cooper Industries/Eaton Corporation  
Office 205/206, 2nd Floor SJ Towers, off. Old Airport Road,  
Abu Dhabi, United Arab Emirates  
Tel: +971 2 44 66 840 Fax: +971 2 44 66 841  
E-mail: mtlgulf@eaton.com

## UNITED KINGDOM

Eaton Electric Limited,  
Great Marlings, Butterfield, Luton  
Beds LU2 8DL  
Tel: +44 (0)1582 723633 Fax: +44 (0)1582 422283  
E-mail: mtlenquiry@eaton.com

## AMERICAS

Cooper Crouse-Hinds MTL Inc.  
3413 N. Sam Houston Parkway W.  
Suite 200, Houston TX 77086, USA  
Tel: +1 800-835-7075 Fax: +1 866-298-2468  
E-mail: mtl-us-info@eaton.com