

THIRD ANGLE PROJECTION

DO NOT SCALE

DIMENSIONS IN mm

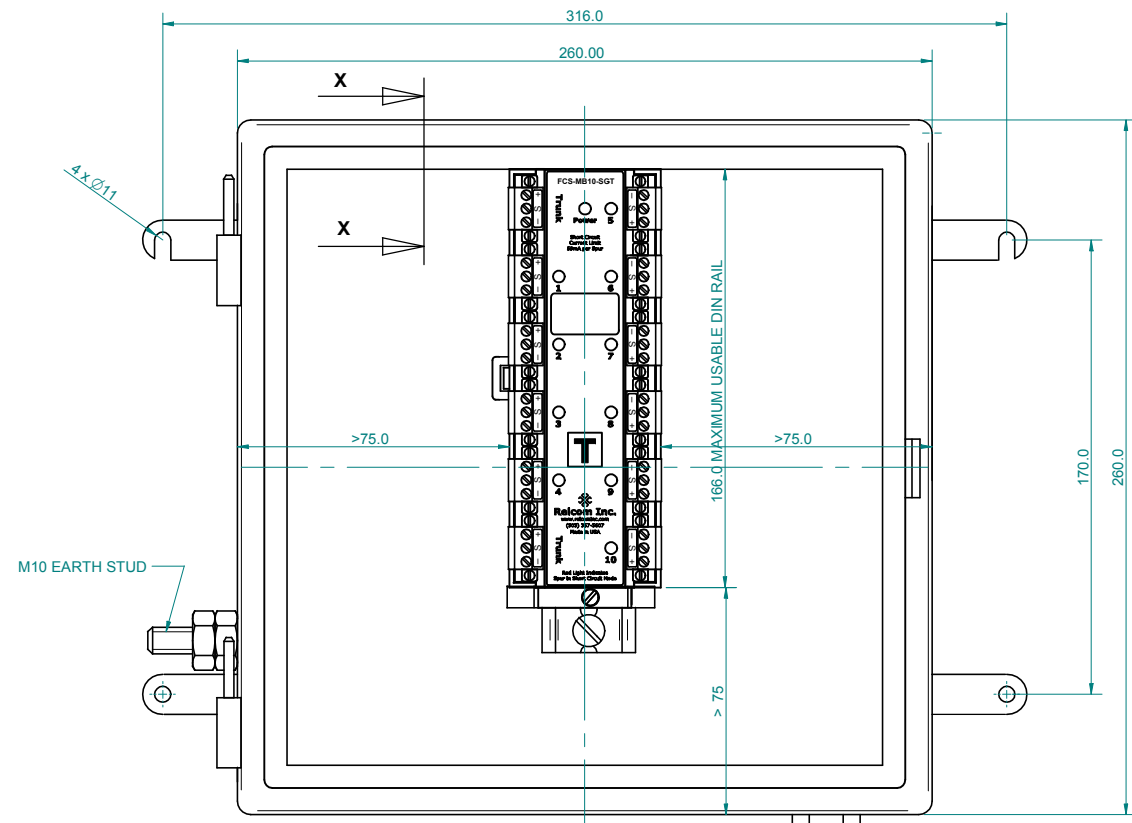

VIEW WITH LID REMOVED

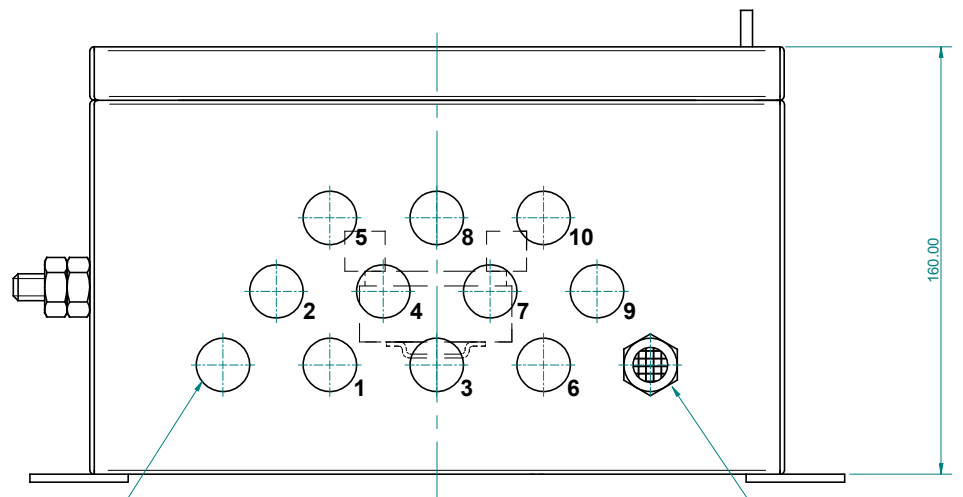
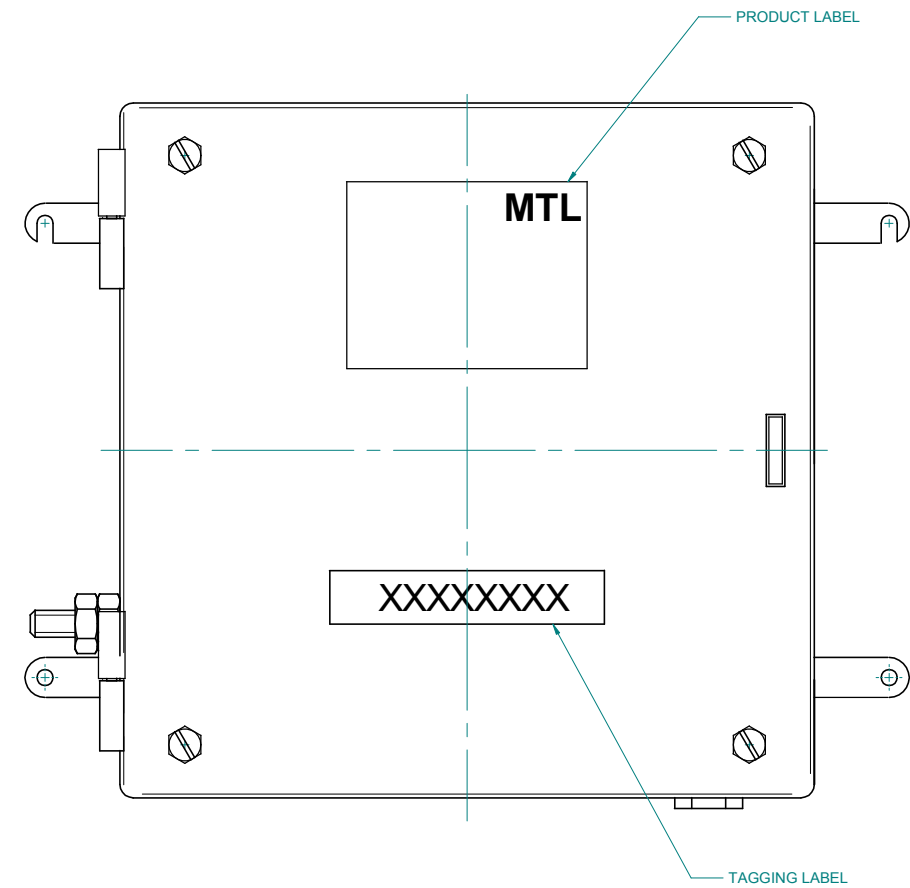

VIEW SHOWING POSITION OF CABLE GLAND AND BREATHER. GLAND NOT SHOWN FOR CLARITY

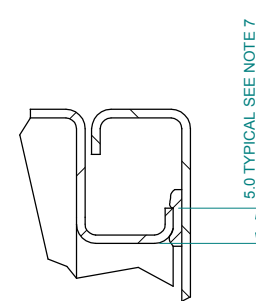

VIEW SHOWING RAIN WATER CHANNEL

NOTES:

1. EEx e TYPE, 1.5mm THICK, IP66 STAINLESS STEEL 316L ENCLOSURE, WITH LEFT HAND HINGED LID, PADLOCK HASP & 3mm THICK MOUNTING FLANGES
2. INTERNAL/ EXTERNAL M10 EARTH STUD FITTED, PLUS EARTH STRAP TO LID.
3. 1 x DIN RAILS TO EN50022 35x7.5 "T" SECTION, MOUNTED VERTICALLY. RAIL FITTED WITH 2 END STOPS.
4. 12 x M20 HOLES DRILLED EQUI-SPACED ON BOTTOM. IP66 EEx e CERTIFIED BREATHER PLUG FITTED IN POSITION SHOWN. 11 x M20 HOLES FOR 1 TRUNK IN & 10 SPUR CONNECTIONS OUT.
5. PART NUMBERS ENDING FCS-9510-XXX-01 TO FCS-9510-XXX-10 INDICATES QUANTITY OF SPUR GLANDS FITTED. ALL UNUSED GLAND POSITIONS ARE FITTED WITH BLANKING PLUGS THAT USE THE SAME MATERIAL AS THE GLANDS. SEE CD-FCS-1000 FOR BLANKING PLUG & GLANDING DETAILS
6. PRODUCT LABEL & TAGGING LABEL (WHERE SPECIFIED), FITTED ON LID ENCLOSURE PART No. LABEL FITTED INSIDE OF LID
7. FLANGE FORMED IN CHANNEL SECTION TO ENSURE WATER DOES NOT ENTER ENCLOSURE WHEN DOOR IS OPENED.
8. JUNCTION BOX DESIGNED FOR MEGABLOCKS WITH 1 DIN RAIL FOR 1 x 10 WAY OR 2, 4, 8 WAY MEGABLOCKS OR OTHER FIELDBUS WIRING COMPONENTS. SEE DATA SHEET APPLICATION EXAMPLES

1	10.04		Scale 1:2	Copyright Reserved Written Permission To Copy Should Be Obtained	Measurement Technology Ltd Power Court, Luton, England	Title PROCESS JUNCTION BOX, STAINLESS STEEL, 10 SPUR	Drg No CD-FCS-9510	Iss. 1
Iss	Date	Modification	Tolerance N/A					

Sht. 1 of 1