

Dimensions in mm

Do Not Scale

Third Angle Projection

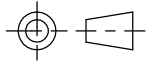

Iss	Date	Modification	MEASUREMENT TECHNOLOGY LTD Luton, England Copyright Reserved - Written Permission to Copy Should be Obtained
1	11.13		

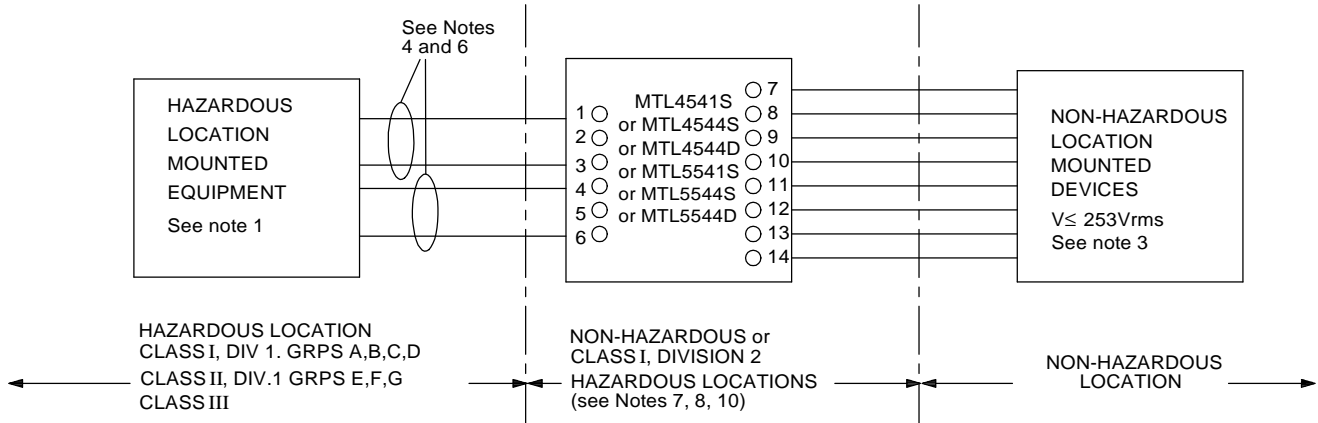

Note 1
 The Hazardous location equipment may be switches or thermocouples. Other apparatus such as RTD's, LEDs and non-inductive resistors may also be used if the auto-ignition temperature of the hazardous location is greater than T4 (275°F or 135°C). Certified devices with correct Entity Concept parameters may also be used. This associated apparatus may also be connected to simple apparatus as defined in Article 504.2 and installed and temperature classified in accordance with Article 504.10 (B) of the National Electrical Code (ANSI/NFPA 70), or other local codes, as applicable.

Note 2
 Selected intrinsically safe equipment must be third party listed as intrinsically safe for the application, and have intrinsically safe entity parameters conforming with Table 1 below. :-

TABLE 1

IS Equipment	Associated Apparatus
V_{max} (or U_i)	$\geq V_{oc}$ or V_t (or U_o)
I_{max} (or I_i)	$\geq I_{sc}$ or I_t (or I_o)
P_{max} , P_i	$\geq P_o$
$C_i + C_{cable}$	$\leq C_a$ (or C_o)
$L_i + L_{cable}$	$\leq L_a$ (or L_o)

Note 3
 Control equipment must not use or generate more than 250Vrms with respect to earth.

Note 4
 For guidance on the installation see ANSI/ISA RP 12.6.

Note 5
 Capacitance and inductance of the field wiring from the intrinsically safe equipment to the associated apparatus shall be calculated and must be included in the system calculations as shown in Table 1. Cable capacitance, C_{cable} , plus intrinsically safe equipment capacitance, C_i must be less than the marked capacitance, C_a (or C_o), shown on any associated apparatus used. The same applies for inductance (L_{cable} , L_i and L_a or L_o , respectively). Where the cable capacitance and inductance per foot are not known, the following values shall be used : $C_{cable} = 60pF/ft.$, $L_{cable} = 0.2 \mu H/ft.$

Note 6
 Non-Hazardous Area Input Terminals 8, 9, 11, 12, 13 & 14:

$U_m = 250V$

The apparatus are designed to operate on the above terminals from d.c. supply voltage of up to 35V.

MTL4541S, MTL5541S

Terminals 3 w.r.t 1; $V_{max} = U_i = 30V$ dc; $I_{max} = I_i$ 121mA dc

MTL4544S, MTL5544S MTL4544D, MTL5544D

Terminals 6 w.r.t 4 $V_{max} = U_i = 30V$ dc $I_{max} = I_i$ 121mA dc

When an intrinsically safe source is connected to these terminals it should have a source resistance of U_i / I_i and the capacitance and either the inductance to resistance ratio (L/R) of the hazardous area connections must not exceed the values for the intrinsically safe source.

System Certificate No:	Tolerance \pm N/A	
	Scale 1:1	Sheet 1 of 3
Certifying Authority:	Title Installation Drawing for the MTL4541S, 44S, 44D and MTL5541S, 44S, 44D	Drg. No. SCI-1063
		Iss 1

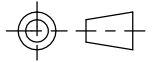

Iss	Date	Modification	MEASUREMENT TECHNOLOGY LTD Luton, England Copyright Reserved - Written Permission to Copy Should be Obtained
1	11.13		

The device has the output entity parameters, as shown in Table 2 below :-

TABLE 2

Terminal nos.	$V_{oc} = U_o$	$I_{sc} = I_o$	C_i	L_i	P_o
2 w.r.t 1	28V	93mA	0	0	0.65W
5 w.r.t 4	28V	93mA	0	0	0.65W
3 w.r.t 1	1.1V	53mA	0	0	15mW
6 w.r.t 4	1.1V	53mA	0	0	15mW

Hazardous Area Terminal 2 and 5 must not be used when the above source is connected to Terminal 3 and 6, see Table 3 below :-

TABLE 3

Terminal nos.	$V_{oc} = U_o$	$I_{sc} = I_o$	C_i	L_i	P_o
2 w.r.t 3	28V	87mA	0	0	0.61W
5 w.r.t 6	28V	87mA	0	0	0.61W

Each channel must be considered as a separate intrinsically safe circuit.

The capacitance and either the inductance or the inductance to resistance ratio (L/R) of the hazardous area load connected must not exceed the values for either channel, as shown in Table 4 below:-

TABLE 4

Group	Capacitance (μF)	Inductance (mH)	L/R Ratio ($\mu H/ohm$)
Hazardous Area Terminals 2 w.r.t 1 or 5 w.r.t 4			
Group A & B	0.083	4.2	56
Group C & E	0.65	12.6	210
Group D, F & G	2.15	33.6	444
Hazardous Area Terminals 3 w.r.t 1 or 6 w.r.t 4			
Group A & B	100	12.8	2,438
Group C & E	1,100	47.8	8,932
Group D, F & G	1,100	104.7	18,140
Hazardous Area Terminals 2 w.r.t 3 or 5 w.r.t 6			
Group A & B	0.083	4.9	59
Group C & E	0.65	20.0	222
Group D, F & G	2.15	40.9	469

Note a)

The above load parameters apply when one of the two conditions below is given:

- The total L_i of the external circuit (excluding the cable) is $<1\%$ of the L_o value or
- The total C_i of the external circuit (excluding the cable) is $<1\%$ of the C_o value

Note b)

The above parameters are reduced to 50% when both of the two conditions below are given:

- The total L_i of the external circuit (excluding the cable) is $\geq 1\%$ of the L_o value and
- The total C_i of the external circuit (excluding the cable) is $\geq 1\%$ of the C_o value

The maximum capacitance allowed shall not be more than $C_o = 600nF$ Groups A & B and $C_o = 1\mu F$ Groups C, D, E, F & G.

Note 7

The module is Associated Apparatus and when mounted in the appropriate enclosure (see notes 11 and 12) is suitable for installation in the following areas:

Non - Hazardous Locations
 Class Division 2 Groups A,B,C and D Hazardous Locations

Note 8

Associated Apparatus must be installed in an enclosure suitable for the application in accordance with the National Electrical Code (ANSI/NFPA 70) for installation in the United States. Intrinsically safe circuits must be wired and separated in accordance with Article 504.20 of the National Electrical Code (ANSI/NFPA 70) or other local codes, as applicable.

Where multiple circuits extend from the same piece of associated apparatus, they must be installed in separate cables or in one cable having suitable insulation. Refer to Article 504.30(B) of the National Electrical Code (ANSI/NFPA 70) and Recommended Practice ISA RP12.6 for installing intrinsically safe equipment.

System Certificate No:	Tolerance \pm N/A	
Certifying Authority:	Scale 1:1	Sheet 2 of 3
Title	Drg. No.	Iss
Installation Drawing for the MTL4541S, 44S, 44D and MTL5541S, 44S, 44D	SCI-1063	1

Dimensions in mm

Do Not Scale

Third Angle Projection

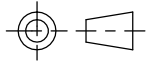

Iss	Date	Modification	MEASUREMENT TECHNOLOGY LTD Luton, England Copyright Reserved - Written Permission to Copy Should be Obtained
1	11.13		

Note 9

This associated apparatus has not been evaluated for use in combination with another associated apparatus.

Note 10

When installed in Class I Division 2 Hazardous Locations, the module must not be removed or inserted unless the area is known to be non-hazardous or the power has been removed.

Note 11

Refer to Instruction Manual for further information.

Note 12

WARNING - Substitution of components may impair intrinsic safety or suitability for Class I, Division 2.

Note 13

WARNING - This equipment is suitable for use in Class I, Division 2, Groups A, B, C and D or non-hazardous locations only when installed in a suitable electrical enclosure.



System Certificate No:		Tolerance \pm N/A	
Certifying Authority:		Scale 1:1	Sheet 3 of 3
Title	Installation Drawing for the MTL4541S, 44S, 44D and MTL5541S, 44S, 44D	Drg. No. SCI-1063	Iss 1