

MTL4575

TEMPERATURE CONVERTER

THC or RTD input + Alarm

The MTL4575 converts a low-level dc signal from a temperature sensor mounted in a hazardous area into a 4/20mA current for driving a safe-area load. Software selectable features include linearisation, ranging, monitoring, testing and tagging for all thermocouple types and 2-, 3- or 4-wire RTDs. (For thermocouples requiring cold-junction compensation, the HAZ-CJC plug can be ordered with the product and includes an integral CJC sensor). Configuration is carried out using a personal computer. A single alarm output is provided and may be configured for high or low process alarm or to provide notice of early thermocouple failure.

SPECIFICATION

See also common specification

Number of channels

One

Signal source

Types J, K, T, E, R, S, B or N THCs to BS 60584 and XK
EMF input
Pt 100, Pt 500, Pt 1000
2/3/4-wire platinum RTDs to BS 60751
Cu-50 & Cu-53
Ni 100/500/1000 DIN 43760

Location of signal source

Zone 0, IIC, T4-6 hazardous area
Division 1, Group A, hazardous location

Input signal range

-75 to +75mV, or 0 to 400 Ω (0 to 1000 Ω Pt & Ni sensors)

Input signal span

3 to 150mV, or 10 to 400 Ω (10 to 1000 Ω Pt & Ni sensors)

RTD excitation current

200 μ A nominal

Cold junction compensation

Automatic or selectable

Cold junction compensation error

$\leq 1.0^{\circ}\text{C}$

Common mode rejection

120dB for 240V at 50Hz or 60Hz (500ms response)

Series mode rejection

40dB for 50Hz or 60Hz

Calibration accuracy (at 20°C)

(includes hysteresis, non-linearity and repeatability)

Inputs: (500ms response)

mV/THC: $\pm 15\mu\text{V}$ or $\pm 0.05\%$ of input value
(whichever is greater)

RTD: $\pm 80\text{m}\Omega$

Output: $\pm 11\mu\text{A}$

Temperature drift (typical)

Inputs:

mV/THC: $\pm 0.003\%$ of input value/ $^{\circ}\text{C}$

RTD: $\pm 7\text{m}\Omega/^{\circ}\text{C}$

Output: $\pm 0.6\mu\text{A}/^{\circ}\text{C}$

Example of calibration accuracy and temperature drift

(RTD input - 500ms response)

Span: 250 Ω

Accuracy: $\pm (0.08/250 + 11/16000) \times 100\%$
 $= 0.1\%$ of span

Temperature drift: $\pm (0.007/250 \times 16000 + 0.6) \mu\text{A}/^{\circ}\text{C}$
 $= \pm 1.0\mu\text{A}/^{\circ}\text{C}$

Hazardous area

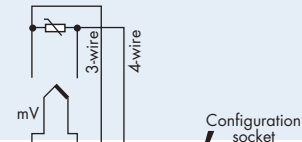

Safe area

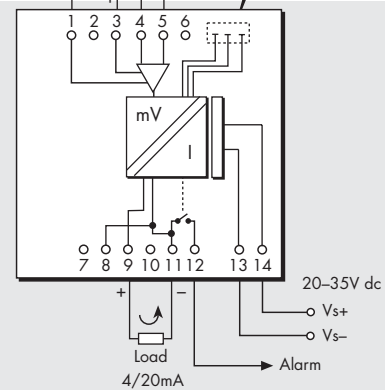

Terminal	Function
1	THC/EMF/RTD input -ve
3	THC/EMF/RTD input +ve
4	3-wire RTD input -ve
5	4-wire RTD input +ve
8	Output -ve
9	Output +ve
11	Output -ve/Alarm relay
12	Alarm relay
13	Supply -ve
14	Supply +ve

Safety drive on sensor burnout

Upscale, downscale, or off

Early burnout

Early burnout detection for thermocouples (when selected)
Alarm trips when loop resistance increase is $> 50\Omega$

Output range

4 to 20mA nominal into 600 Ω max. (direct or reverse)

Alarm output

Relay ON in alarm, 250mA @ 35V max

Maximum lead resistance (THC)

600 Ω

Response time

Configurable - 500 ms default
(Accuracy at 100/200ms - contact MTL)

LED indicator

Green: power and status indication
Yellow: alarm indication, on when contacts are closed

Maximum current consumption (with 20mA signal)

50mA at 24V

Power dissipation within unit (with 20mA signal)

1.2W at 24V

Safety description

Refer to certificate for entity parameters. $U_m=253\text{V}$ rms or dc.

Configurator

A personal computer running MTL PCS45 software with a PCL45USB serial interface.

