

# *F809F FOUNDATION fieldbus™*

## *Diagnostics module*



**Instruction Manual**

**INM F809F**





# CONTENTS

PAGE

<b>General information</b> .....	<b>iv</b>
Safety instructions for installation and operating personnel .....	iv
<b>1 Overview</b> .....	<b>1</b>
1.1 Manual .....	1
<b>2 Installation</b> .....	<b>2</b>
2.1 Mounting .....	2
2.2 Power requirements .....	2
2.3 Configuration of fieldbus communication segment .....	2
2.4 Installation for communication on separate fieldbus segment .....	3
2.5 Ground Reference Switch .....	4
<b>3 Configuration</b> .....	<b>4</b>
3.1 Standard .....	4
3.2 F809F Configuration .....	4
<b>4 Block Configuration</b> .....	<b>5</b>
4.1 Resource Block .....	5
4.2 Transducer Blocks .....	7
4.3 Discrete Input Block .....	17
<b>5 Operation and Maintenance</b> .....	<b>18</b>
5.1 LED indicators .....	18
5.2 FOUNDATION Fieldbus Information .....	18
5.3 Hardware Maintenance .....	18
5.4 Troubleshooting .....	19
<b>Appendix A: Troubleshooting Table</b> .....	<b>20</b>

## GENERAL INFORMATION

This manual applies to Diagnostic Module F809F version **MT02** which, for current models, is indicated on the side label.

It can also apply to earlier model that have had a firmware update. Check in the Resource transducer block (see section 4.1) to ensure that the following values apply:

Parameter 42 - Identification\_Measurement - software version 1.1x

Parameter 43 - Identification\_Fieldbus - software version 1.3x

For all models with software releases earlier than these, refer to manual **INM F809F-1** which is available for download from <http://www.mtl-inst.com/mtlsupport.nsf>

### Safety instructions for installation and operating personnel

These operating instructions contain basic safety instructions for installation, operation and maintenance and servicing. Failure to comply with these instructions can endanger personnel, the plant and the environment.

#### Before installation/commissioning:

- ▶ Read the operating instructions.
- ▶ Give adequate training to the installation and operating personnel.
- ▶ Ensure that the contents of the operating instructions are fully understood by responsible personnel.
- ▶ The national installation and mounting regulations (e.g. EN 60079-14) apply.

#### When operating the devices:

- ▶ Make the operating instructions available at the installation area (at all times).
- ▶ Observe safety instructions.
- ▶ Observe national safety and accident prevention regulations.
- ▶ Operate the equipment within its published specification.
- ▶ Servicing/maintenance work or repairs which are not described in the operating instructions must not be performed without prior agreement with the manufacturer.
- ▶ Any damage may render hazardous-area protection null and void.
- ▶ No changes to the devices or components impairing their hazardous-area protection are permitted.
- ▶ The device may only be fitted and used if it is in an undamaged, dry and clean state.

#### If there are any points that remain unclear:

- ▶ Contact your local MTL Office
- ▶ Product and contact details are also available from the company website: <http://www.mtl-inst.com>



## 1 OVERVIEW

The F809F Fieldbus Diagnostic Module is available as an option for use with F800 Series and some F600 Series fieldbus power supplies. It plugs into an F8xx or F6x8 Series power supply carrier, or an F8x8 diagnostic module carrier and monitors the performance of each of the eight fieldbus segments, providing information on the network health and capturing retransmissions between the fieldbus devices and control system.

The parameters measured include the bulk power supply input voltage, temperature, segment voltages and signal levels of all devices. Average and peak noise are measured in each of three frequency bands. Additionally the monitor checks for correct bus termination and for short-circuits between the fieldbus signal wires and cable shields. The measured physical layer parameters are used to predict the corrective action required. This allows problems to be rectified before poor network health results in devices being removed from the 'live list', which could affect the operation of the plant. Measurements may alternatively be captured and sent to off-site experts for interpretation.

The F809F is a FOUNDATION fieldbus™ device, and communicates with the host control system via a fieldbus segment. This allows the network status and measured parameters to be displayed in the instrument management software on the host control system.

### 1.1 Manual

This manual is designed to assist in the installation, configuration and maintenance of the F809F Fieldbus Diagnostic Module version MT02 (see side label), or versions with updated firmware, as explained on the opposite page under General Information.

For product specification see the EPS F809F data sheet.

New features of this version include:

- Parameters can be configured when blocks are OOS
- Option to display null values and clear all alarms when segment is disabled
- 8 instances of one block type
- Operations can now be performed on hosts that do not support methods
- Pre-alarms added: High-High, High, Low, Low-Low
- Short to shield differentiates between +ve and -ve
- Device lists maintained when module power cycled
- Latching alarms acknowledgement option (v1.2x provides auto-acknowledgement of alarms)
- New self test fault flags
- Option provided to reset the measurement processor
- Firmware compatibility check introduced
- Self test log introduced

## 2 INSTALLATION

The F809F is designed for carrier mounting and may be mounted on any MTL F8xx or F6x8 series carrier. See the MTL F8xx or F6x8 series power supply or F8x8 carrier installation manual for details of how these carriers are installed.

The F809F Fieldbus Diagnostic Monitor receives redundant power feeds and connections to the eight monitored fieldbus segments via the carrier. The diagnostic information is conveyed to the controlling host via a fieldbus segment and the user has the choice of segment 1 or 8 (of the segments being monitored), or a totally separate segment of their choosing. The segment chosen for communication is configured using a plug-in connector located on the front edge of the module.

### 2.1 Mounting

Align the F809F module with the two multi-pin connectors\* on the carrier and hold it in place while tightening the two captive fixing screws.

**Note:** the fixing screws should be tightened to a minimum torque value of 1.2Nm, but should not exceed a torque value of 1.5Nm.

To remove the F809F, support the module while unscrewing the two fixing screws at its base. Lift the module off the carrier connector.



Figure 2-1: Unused connector

\* A third connector is provided on the module for factory testing and firmware upgrade. This connector, the largest of the three, is not used on the carrier and is identified on the F809F side label. See Figure 2-1.



Figure 2-2: Configuration "comb"

### 2.2 Power requirements

An F809F module draws approximately 15mA from the communicating fieldbus segment. This needs to be included when calculating the total design current requirement for that segment.

### 2.3 Configuration of fieldbus communication segment

The communications segment that will be used is determined by configuring the connector on the front face of the module. A 6-pin "comb", supplied with the module, is used to define the communication segment by inserting it one of two ways into the connector (see Figure 2-2), or omitting it altogether.

The F809F can also be ordered pre-configured for the required fieldbus communication segment by requesting the part number shown here.

#### Part No Configuration

<b>F809F</b>	Communicates on segment 8 (eight) of the monitored fieldbus segments
<b>F809F-1</b>	Communicates on segment 1 (one) of the monitored fieldbus segments
<b>F809F-9</b>	Communicates on a separate fieldbus segment

The communication segment can be changed "in the field" by a simple change to the connector on the front face.



Figure 2-3: Removing protective cap

1. Remove the protective cap from the top of the fieldbus module by squeezing the ends. See Figure 2-3.
2. Loosen the six screws in the connector.
3. Remove the "comb" from the connector (F809F or F809F-1), or obtain the connector "comb" from the packaging (F809F-9).
4. (a) **For communication on segment 8**  
Place the "comb" in the connector, as shown (Figure 2-2), so that the number "8" is visible on the top (right) surface.  
(b) **For communication on segment 1**  
Place the "comb" in the connector so that the number "1" is visible on top (right) surface.  
(c) **For communication on a separate segment**  
No comb is required.
5. If the comb is being used, tighten the six screws to retain it.
6. Replace the protective cap.

## 2.4 Installation for communication on separate fieldbus segment

If a separate fieldbus segment is the chosen option, then it can communicate the diagnostic data via the top connector on the F809F or, in some cases, through dedicated connectors on the carrier. The table below shows which carriers (by batch code) provide this option.

Carrier type	Diagnostic data connection options	
	via carrier	via top connector
F618D-CL	All	All
F860-CA	None	All
F880-CR-xx	None	All
F880-CL-xx	None	All
F880-CA-xx	0727 or later	All
F888-CA-xx	All	All
F890-CA-xx	0727 or later	All
F892-CA-xx	0727 or later	All
F898-CA-xx	All	All

### 2.4.1 Interconnection via carrier

Figure 2-4 shows how a dedicated diagnostic segment, comprising multiple F6x8 or F8xx carriers, is interlinked, powered and terminated. Where carriers are installed in vertical columns, connect the H1+, H1- and S terminals of adjacent carriers as shown.

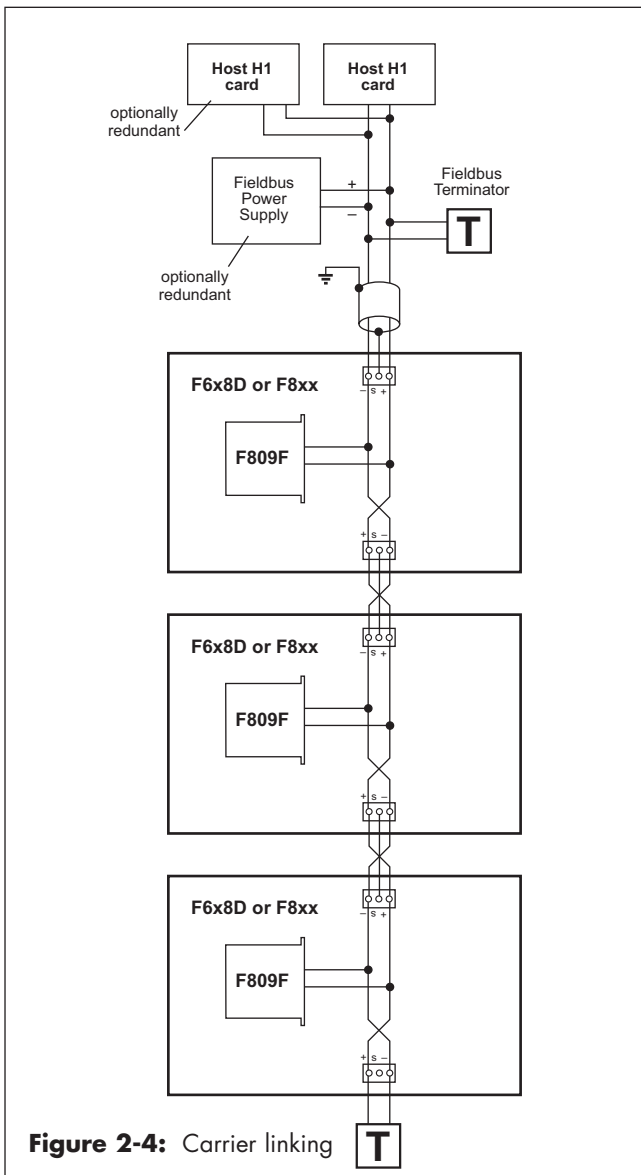

### 2.4.2 Interconnection via top connector

Figure 2-5 shows how a dedicated diagnostic segment comprising multiple F8xx carriers is interlinked and terminated. The fieldbus spur is connected to the two middle terminals in the top connector - see Figures 2-2 and 2-6.

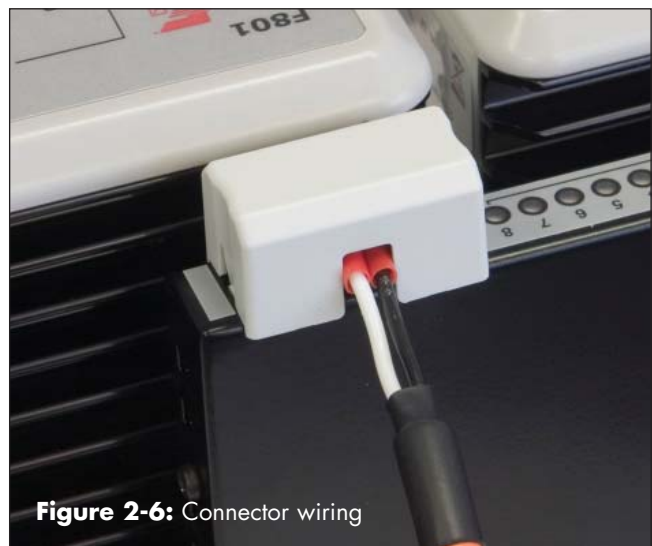
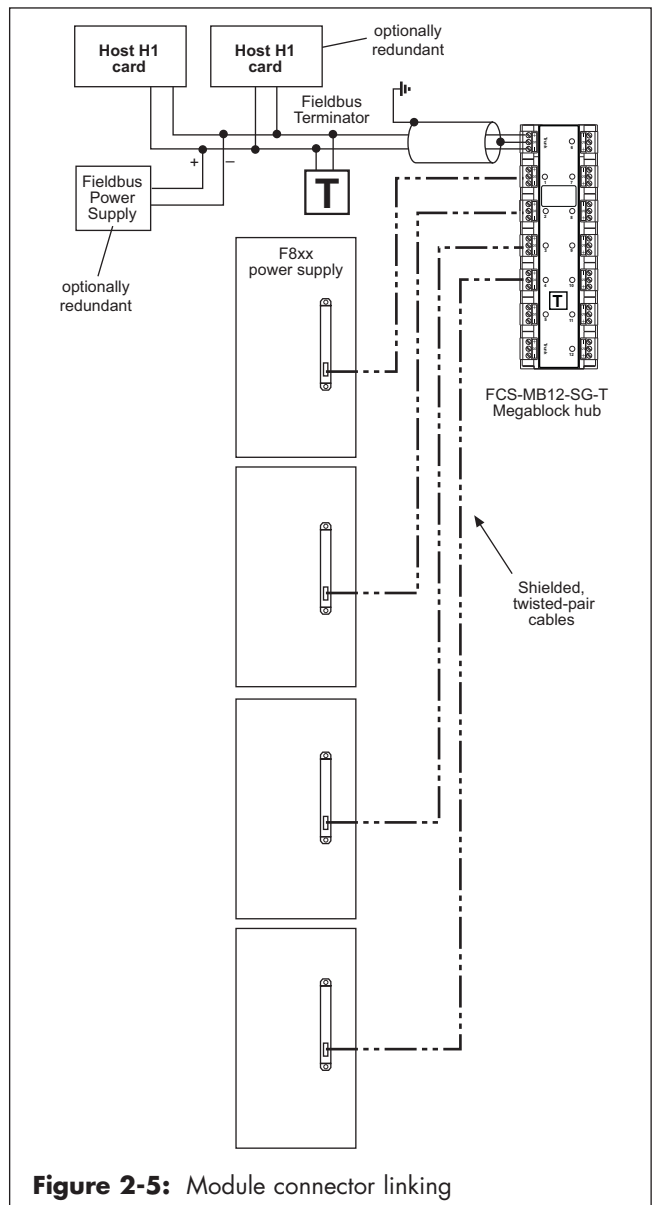

### 2.4.3 Fieldbus segment design rules

A segment may support a number of F809F modules. The actual number is based on a number of factors:

- the logical device limit of the host,
- the fieldbus power supply capacity,
- operational constraints such as bandwidth
- the overall impact on the system if that diagnostic segment should be lost.

Shielded, twisted-pair cable, complying with FOUNDATION FIELDBUS 'Type A' construction is recommended for the diagnostic segment. Unshielded instrument cable is suitable for interconnections between adjacent carriers.

### 2.4.4 Diagnostics module power supply

The diagnostic segment must be powered by a conditioned fieldbus power supply (see Figure 2-4 & 2-5) that will provide a voltage in the range 9–32V DC at each F809F fieldbus diagnostic module. This power supply may be either simplex or redundant, depending on the application, and be capable of providing sufficient current for the entire diagnostic segment.

Each F809F module draws approximately 15mA, so a segment comprising 10 modules, for example, will require an output current of at least 150mA. Suitable redundant fieldbus power supplies could be MTL-Relcom type F800 or FPS-I, either of which can provide 350mA at 21.5V to 28V DC depending on model. Alternatively, type FPS-DT will provide enough for two segments of non-redundant power.

### 2.4.5 Diagnostics module segment termination

As with all Fieldbus segments, the one used for the diagnostic data must be terminated at both ends to maintain the bus impedance within FOUNDATION fieldbus™ limits. When interconnections are via the carrier, a terminator must be connected between the H1+ and H1- terminals of the diagnostic bus connector at the far end of the segment (see Figure 2-4). Suitable terminators for this are MTL type FBT1-IS or F100.

When interconnection is via the top connector, the recommended method is to use a Megablock with a built-in terminator to interconnect the fieldbus spurs and terminate the bus (see Figure 2-5). Termination of the bus at the host end may be provided either by an integrated terminator within the power supply (such as exists within the FPS-I, FPS-DT and F800 types) or by means of a separate terminator.

## 2.5 Ground Reference Switch

The ground reference switch is normally used in position '1' - see Figure 2-7. For use with the F618D carrier refer to the instruction manual INMF618D (Revision 2 or later).

**Figure 2-7:**  
Ground reference switch set to '1'



A separate case ground terminal is provided (Figure 2-8) to enable the case of the module to be linked to a ground terminal on the circuit board.

**Figure 2-8:**  
Case ground terminal



## 3 CONFIGURATION

### 3.1 Standard

Each FOUNDATION fieldbus™ configuration tool or host system has a different way of displaying and performing configurations. Some will use Device Descriptions (DDs) and DD Methods to make configuration and displaying of data consistent across host platforms.

Refer to the fieldbus control system's documentation to perform configuration changes using a Foundation fieldbus host or configuration tool.

The function of the F809F is to provide diagnostic data, therefore configuration changes can be made with the MODE\_BLK.ACTUAL in AUTO or Out Of Service (OOS) mode.

**NOTE:** Fieldbus devices used in process applications usually have to be set to OOS mode before making configuration changes.

### 3.2 F809F Configuration

The F809F is available with the standard configuration setting. The configuration settings and block configuration may be changed in the field with the FOUNDATION fieldbus host or a configuration tool.



## 4 BLOCK CONFIGURATION

### 4.1 Resource Block

The resource block defines the physical resources of the device including type of measurement, memory, etc. The resource block also defines functionality, such as shed times, that is common across multiple blocks. The block has no linkable inputs or outputs and it performs memory-level diagnostics.

**Table 4-1.** Resource Block Parameters

Number	Parameter	Description
00	BLOCK	
01	ST_REV	The revision level of the static data associated with the function block.
02	TAG_DESC	
03	STRATEGY	The strategy field can be used to identify grouping of blocks.
04	ALERT_KEY	The identification number of the plant unit.
05	MODE_BLK	The ACTUAL, TARGET, PERMITTED, and NORMAL modes of the block. For further description, see the Mode parameter formal model in FF-890.
06	BLOCK_ERR	This parameter reflects the error status associated with the hardware or software components associated with a block. Multiple errors may be shown. For a list of enumeration values, see FF-890, Block_Err formal model.
07	RS_STATE	State of the function block application state machine. For a list of enumeration values, see FF-890.
08	TEST_RW	Read/write test parameter - used only for conformance testing.
09	DD_RESOURCE	String identifying the tag of the resource which contains the Device Description for the resource.
10	MANUFAC_ID	Manufacturer identification number - used by an interface device to locate the DD file for the resource.
11	DEV_TYPE	Manufacturer's model number associated with the resource - used by interface devices to locate the DD file for the resource.
12	DEV_REV	Manufacturer revision number associated with the resource - used by an interface device to locate the DD file for the resource.
13	DD_REV	Revision of the DD associated with the resource - used by the interface device to locate the DD file for the resource.
14	GRANT_DENY	Options for controlling access of host computer and local control panels to operating, tuning and alarm parameters of the block.
15	HARD_TYPES	The types of hardware available as channel numbers. The supported hardware type is: SCALAR_INPUT
16	RESTART	Allows a manual restart to be initiated. See also Section 5.4.2
17	FEATURES	Used to show supported resource block options. The supported features are: SOFT_WRITE_LOCK_SUPPORT and REPORTS.
18	FEATURE_SEL	Used to select resource block options.
19	CYCLE_TYPE	Identifies the block execution methods available for this resource. The supported cycle types are: SCHEDULED, and COMPLETION_OF_BLOCK_EXECUTION.
20	CYCLE_SEL	Used to select the block execution method for this resource.
21	MIN_CYCLE_T	Time duration of the shortest cycle interval of which the resource is capable.
22	MEMORY_SIZE	Available configuration memory in the empty resource. To be checked before attempting a download.
23	NV_CYCLE_T	Minimum time interval specified by the manufacturer for writing copies of NV parameters to non-volatile memory. Zero means it will never be automatically copied. At the end of NV_CYCLE_T, only those parameters which have changed need to be updated in NVRAM.
24	FREE_SPACE	Percent of memory available for further configuration. Zero in preconfigured resource.
25	FREE_TIME	Percent of the block processing time that is free to process additional blocks.
26	SHED_RCAS	Time duration at which to give up on computer writes to function block RCAs locations. Shed from RCAs will never happen when SHED_RCAS = 0.
27	SHED_ROUT	Time duration at which to give up on computer writes to function block ROut locations. Shed from ROut will never happen when SHED_ROUT = 0.
28	FAULT_STATE	Condition set by loss of communication to an output block, fault promoted to an output block or physical contact. When faultstate condition is set, then output function blocks will perform their FSTATE actions.

Number	Parameter	Description
29	SET_FSTATE	Allows the FAIL_SAFE condition to be manually initiated by selecting Set.
30	CLR_FSTATE	Writing a Clear to this parameter will clear the device FAIL_SAFE if the field condition has cleared.
31	MAX_NOTIFY	Maximum number of unconfirmed notify messages possible.
32	LIM_NOTIFY	Maximum number of unconfirmed alert notify messages allowed.
33	CONFIRM_TIME	The time the resource will wait for confirmation of receipt of a report before trying again. Retry will not happen when CONFIRM_TIME=0.
34	WRITE_LOCK	If set, all writes to static and non-volatile parameters are prohibited, except to clear WRITE_LOCK. Block inputs will continue to be updated.
35	UPDATE_EVT	This alert is generated by any change to the static data.
36	BLOCK_ALM	The BLOCK_ALM is used for all configuration, hardware, connection failure or system problems in the block. The cause of the alert is entered in the subcode field. The first alert to become active will set the Active status in the Status attribute. As soon as the Unreported status is cleared by the alert reporting task, another block alert may be reported without clearing the Active status, if the subcode has changed.
37	ALARM_SUM	The current alert status, unacknowledged states, unreported states, and disabled states of the alarms associated with the function block.
38	ACK_OPTION	Selection of whether alarms oscillated with the block will be automatically acknowledged.
39	WRITE_PRI	Priority of the alarm generated by clearing the write lock.
40	WRITE_ALM	This alert is generated if the write lock parameter is cleared.
41	ITK_VER	Major revision number of the interoperability test case used in certifying this device as interoperable. The format and range are controlled by the Fieldbus Foundation.
42	IDENTIFICATION_MEASUREMENT (PRODUCT_ID, SERIAL_NUMBER, HW_REVISION, SOFTWARE_VERSION, FIRMWARE_CRC)	Measurement product ID, serial number, hardware revision and software version. View as hexadecimal number.
43	IDENTIFICATION_FIELDBUS (SERIAL_NUMBER, HW_REVISION, SOFTWARE_VERSION, FIRMWARE_CRC)	Fieldbus serial number, hardware revision and software version. View as hexadecimal number.

#### 4.1.1 Block Errors

Table 4-2 lists all conditions in the BLOCK\_ERR parameter, with conditions in **bold** supported by the F809F.

**Table 4-2.** BLOCK\_ERR Conditions

Number	Name and Description
<b>0</b>	<b>Other</b>
1	Block Configuration Error
2	Link Configuration Error
<b>3</b>	<b>Simulate Active</b>
4	Local Override
5	Device Fault State Set
<b>6</b>	<b>Device Needs Maintenance Soon</b>
7	Input failure/process variable has bad status
8	Output Failure
9	Memory Failure
<b>10</b>	<b>Lost Static Data:</b> Static data that is stored in non-volatile memory has been lost.
11	Lost NV Data
12	Readback Check Failed
<b>13</b>	<b>Device Needs Maintenance Now</b>
14	Power Up: The device was just powered-up.
<b>15</b>	<b>OOS:</b> The actual mode is out of service.

## 4.1.2 Modes

The resource block supports two modes of operation as defined by the MODE\_BLK parameter:

### Automatic (Auto)

The block is processing its normal background memory checks. In this mode, changes can be made to all configurable parameters.

### Out of Service (OOS)

The block is not processing its tasks. The BLOCK\_ERR parameter shows Out of Service. In this mode, changes can be made to any configurable parameters. The target mode of a block may be restricted to one or more of the supported modes.

## 4.2 Transducer Blocks

There are two types of transducer blocks that allow the user to view and manage the channel information. These blocks are:

- System Transducer Block (SysTB) – see “System Transducer Block (SysTB)” in Section 4.2.4.
- Segment Transducer Block (SegTB), one for each of the eight segments – see “Segment Transducer Block (SegTB)” in Section 4.2.5.

These Transducer blocks contain specific diagnostic data.

### 4.2.1 Transducer Block Errors

The following conditions are reported in the BLOCK\_ERR parameters. Conditions in **bold** are supported in the transducer blocks.

**Table 4-3.** Block/Transducer Error

#### BLOCK\_ERR

Condition Number	Name and Description
0	Other
1	Block configuration error
2	Link configuration error
3	Simulate active
4	Local override
5	Device fault state set
<b>6</b>	<b>Device needs maintenance soon</b>
<b>7</b>	<b>Input failure</b>
8	Output failure
9	Memory failure
10	Lost static data
11	Lost NV data
12	Readback check failed
13	Device needs maintenance now
14	Power up: The device was just powered up
<b>15</b>	<b>Out of service:</b> The actual mode is out of service

## 4.2.2 Transducer Block Modes

The transducer block supports two modes of operation as defined by the MODE\_BLK parameter:

### Automatic (Auto)

The block outputs reflect the diagnostic measurement board inputs. In this mode, changes can be made to all configurable parameters.

### Out of Service (OOS)

The block is not processed. Channel outputs are not updated and the status is set to Bad: Out of Service for each channel. The BLOCK\_ERR parameter shows Out of Service. In this mode, changes can be made to any configurable parameters. The target mode of a block may be restricted to one or more of the supported modes.

## 4.2.3 Transducer Block Alarm Detection

If any alarm (except the new and removed device alerts) is set within the Transducer Block then the Needs Maintenance Soon Bit is set in the BLOCK\_ERR parameter. The regular monitoring by the control system of the BLOCK\_ERR parameter can be used to inform the right person of the alarm condition. Typically this will be the instrument technician responsible for fieldbus network maintenance.

Additionally if any alarm is set in the Transducer Block then the Segment Alarm DI Block PV\_D will be set to 1. By configuring the DI block in the fieldbus cyclic messaging the right person can be informed of the alarm condition.

It is recommended to select only one of these options for alarm handling.

## 4.2.4 System Transducer Block (SysTB)

There is one SysTB in the F809F, which allows the user to view system and self-test alarms together with the system power feed voltages and temperature. The SysTB allows configuration of the time, the date and the segments monitored. Additionally, for each device on each of the 8 monitored fieldbus segments, the re-transmission counter can be reset and device history data can be deleted from within this block.

**Table 4-4. Measurement Transducer Block Parameters**

Rel-index	Parameter Name	Description	Help Text	Default alarm limit
0	BLOCK_HEADER	In the BLOCK_HEADER record of a transducer block only the element BLOCK_TAG is writable.		
1	ST_REV	The revision level of the static data associated with the function block.		
2	TAG_DESC	The user description of the intended application of the block.		
3	STRATEGY	The strategy field can be used to identify grouping of blocks.		
4	ALERT_KEY	The identification number of the plant unit.		
5	MODE_BLK	The ACTUAL, TARGET, PERMITTED, and NORMAL modes of the block. For further description, see the Mode parameter formal model in FF-890.		
6	BLOCK_ERR	This parameter reflects the error status associated with the hardware or software components associated with a block. Multiple errors may be shown. For a list of enumeration values, see FF-890, Block_Err formal model.		
7	UPDATE_EVT	Update Event		
8	BLOCK_ALM	Block Alarm		
9	TRANSDUCER_DIRECTORY	Transducer Directory		
10	TRANSDUCER_TYPE	Transducer Type		
11	XD_ERROR	XD Error		
12	COLLECTION_DIRECTORY	Collection Directory		
13	PRIMARY_VALUE_D			
14	POWER_FEED_A_VOLTAGE	Power Feed A Voltage		

Rel-index	Parameter Name	Description	Help Text	Default alarm limit
15	POWER_FEED_B_VOLTAGE	Power Feed B Voltage		
16	MODULE_TEMPERATURE	Module Temperature		
17	SYSTEM_ALARMS	System Alarms	Module temperature high and high-high alerts; Power feed B voltage low-low, low, high and high-high alerts; Power feed A voltage low-low, low, high and high-high alerts;	
18	LATCHING_ALARM_ACKNOWLEDGE		Acknowledges all active alarms in this transducer block.	
19	ALARM_ACKNOWLEDGE_REQUIRED		New alarms require acknowledgement.	
20	SELF_TEST_FAULT_ALARMS	Self Test Fault Alarms		
21	SELF_TEST_LOG_1			
22	SELF_TEST_LOG_2			
23	POWER_FEED_A_VOLTAGE_LIMITS	Power Feed A Voltage Limits	The default values are limits for MTL fieldbus power supply input voltages. The user may reset to output limits of bulk power supply taking into account voltage drop in wiring at minimum and maximum load.	Low Low = 19.2V Low = 19.2V High = 30V High High = 30V
24	POWER_FEED_B_VOLTAGE_LIMITS	Power Feed B Voltage Limits	The default values are limits for MTL fieldbus power supply input voltages. The user may reset to output limits of bulk power supply taking into account voltage drop in wiring at minimum and maximum load.	Low Low = 19.2V Low = 19.2V High = 30V High High = 30V
25	MODULE_TEMPERATURE_LIMITS	Module Temperature Limits	The default values are limits for the F801 fieldbus power supply maximum operating temperature of 65°C. The user may reset this to the maximum operating temperature of the power supply used or select a lower limit based on normal operating temperature of the cabinet. Setting the limit at the lower of the maximum operating temperature of the power supply or 10°C above the normal operating temperature is recommended.	High = 65°C High High = 65°C
26	RESET_MEASUREMENT_PROCESSOR	Reset Measurement Processor	Reset measurement processor to recover from fault state. <b>Warning!</b> Resetting measurement processor will delete device and segment tag data. Ensure this is backed up and download these parameters after reset.	
27	SET_DATE_TIME	Set Date Time	Set the time manually if the Host does not support an automatic update.	
28	SET_MONITORED_SEGMENTS	Set Monitored Segments	The default value is to monitor all 8 segments. If any segments are not in use these may be omitted from the scan. Whilst investigating an issue on a segment, select only that segment number to scan only that segment. After resolving the issue scanning should be reset to all active segments.	

Rel-index	Parameter Name	Description	Help Text	Default alarm limit
29	SET_NON_SCANNING_SEGMENTS_TO_NULL		The default is to display the last measured values for the segment. If any segments are not in use it is recommended to set to display null values and disable scanning on these segments.	
30	RESET_RETRANSMIT_COUNTERS_METHODS (SELECT_BITMAP, SEGMENT_NR, DEVICE_NR)		Parameter associated with method to delete selected retransmission counters.	
31	DELETE_SGM_DEV_DATA_METHODS (SELECT_BITMAP, SEGMENT_NR, DEVICE_NR)		Parameter associated with method to delete device history data..	
32	RESET_RETR_COUNT_U	Reset Transmission Counters	Parameter used to delete selected retransmission counters in systems not supporting methods.	
33	DEL_DATA_U	Delete data	Parameter used to delete selected device history in systems not supporting methods. <b>Warning! This will delete all history data for the selected device.</b> Device data is stored with the device address assigned by the host system. Only delete data if a device address will be no longer used on a segment or a device address is to be assigned to a different device type.	
34	SET_ALARMS_TO_LATCH		Set if alarm acknowledgement is required. Default is alarms do not require acknowledgement.	

#### 4.2.4.1 System alarms

Value	Name and Description	Help Text
0x80000000	Power Feed A Voltage High-High Alarm	check bulk power supply operation
0x40000000	Power Feed A Voltage High Alarm	
0x20000000	Power Feed A Voltage Low Alarm	
0x10000000	Power Feed A Voltage Low-Low Alarm	
0x08000000	Power Feed B Voltage High-High Alarm	
0x04000000	Power Feed B Voltage High Alarm	
0x02000000	Power Feed B Voltage Low Alarm	
0x01000000	Power Feed B Voltage Low-Low Alarm	
0x00800000	Module Temperature High-High Alarm	check cooling in power supply cabinet
0x00400000	Module Temperature High Alarm	

#### 4.2.4.2 Self test alarms

Value	Name and Description	Help Text
0x8000	Measurement processor in Fault State	
0x4000	EEPROM not programmed	
0x2000	EEPROM data corrupt	
0x1000	Relay stuck	
0x0800	RAM error	
0x0400	FLASH corrupt	
0x0200	Watchdog failure	
0x0100	Data corrupt	
0x0080	Internal watchdog reset	
0x0040	Processor to Processor communication lost	
0x0020	Incompatible Firmware	

If any segments are not in use they may be omitted from the scan using the Set Monitored Segments parameter. It is recommended that non-scanning segments are set to display 'null' values, this avoid the confusion of old data being displayed when scanning is disabled. The default is to 'maintain last values', which is usually preferred when scanning is temporarily disabled; for example, while troubleshooting a segment.

The default configuration is for the F809F alarms to Auto acknowledge, so the operator would observe the alarms when the Instrument Management Software displays an alarm in the F809F transducer block. In applications where it is required for the operator to acknowledge transducer block alarms then the Set Alarms to Latch parameter should be set for the System and Segment Transducer Blocks.

The default configuration sets the same limits for alarms and pre-alarms. The low and high alarm limits may be optimised by the user as described in the parameter help text.

#### 4.2.4.3 Methods

For FOUNDATION fieldbus hosts or configuration tools that support DD methods, there are 3 configuration methods available in the Systems Transducer block. These methods are included with the device description (DD) software.

- Setting Date and Time
- Resetting retransmission counter
- Deleting device data

#### Hosts that do not support DD Methods

For hosts that do not support DD methods, resetting retransmission counters and deleting device data can be performed using parameters in the System Transducer Block. This is described in the parameter help text.

#### 4.2.5 Segment Transducer Block (SegTB)

Each of the eight monitored fieldbus segments is supported by a SegTB that provides all the measured parameters and associated alarms for the fieldbus segment and devices. The user can assign segment and device tags within this block. Additionally the segment and device alarm limits may be changed by the user..

**WARNING:** the device tags are held in volatile memory. The F809F is designed to be powered by redundant reliable power feeds. If both power feeds fail at the same time, or the the F809F is removed from the carrier, then the segment and device tag data will be lost. It is recommended to retain this data in the systems Instrument Management Software, so if an F809F module is replaced, the data can be downloaded to the new module.

**Table 4-5. Segment Transducer Block Parameters**

Rel-index	Parameter Name	Description	Help Text	Default alarm limit
0	BLOCK_HEADER			
1	ST_REV	The revision level of the static data associated with the function block.		
2	TAG_DESC	The user description of the intended application of the block.		
3	STRATEGY	The strategy field can be used to identify grouping of blocks.		
4	ALERT_KEY	The identification number of the plant unit.		
5	MODE_BLK	The actual, target, permitted, and normal modes of the block. For further description, see the Mode parameter formal model in FF-890.		
6	BLOCK_ERR	This parameter reflects the error status associated with the hardware or software components associated with a block. Multiple errors may be shown. For a list of enumeration values, see FF-890, Block_Err formal model.		
7	UPDATE_EVT	Update Event		
8	BLOCK_ALM	Block Alarm		
9	TRANSDUCER_DIRECTORY	Transducer Directory		
10	TRANSDUCER_TYPE	Transducer Type		
11	XD_ERROR	XD Error		
12	COLLECTION_DIRECTORY	Collection Directory		
13	PRIMARY_VALUE_D			
14	MONITORING_STATUS	Monitoring status. Status options are: segment monitored; segment not monitored, last values displayed; segment not monitored, null values displayed		
15	SEGMENT_TAG	The user description of the segment		
16	SEGMENT_VOLTAGE	Segment Voltage		
17	AVG_LF_NOISE	Average Low Frequency Noise	Average low frequency noise (250Hz - 3.8kHz)	
18	AVG_IF_NOISE	Average In-Band Frequency Noise	Average in-band or fieldbus frequency noise (5 kHz - 55kHz)	
19	AVG_HF_NOISE	Average High Frequency Noise	Average high frequency noise (90 kHz - 350kHz)	
20	PEAK_LF_NOISE	Peak Low Frequency Noise	Peak low frequency noise (250Hz - 3.8kHz) detected by the diagnostic module over the last hour.	
21	PEAK_IF_NOISE	Peak In-Band Frequency Noise	Peak in-band or fieldbus frequency noise (5 kHz - 55kHz) detected by the diagnostic module over the last hour.	
22	PEAK_HF_NOISE	Peak High Frequency Noise	Peak high frequency noise (90 kHz - 250kHz) detected by the diagnostic module over the last hour.	
23	LIVE_DEVICE_COUNT	Live Device Count	Number of fieldbus devices communicating on the network segment.	
24	LAS_DEVICE_TAG	LAS Device Tag		
25	LAS_DEVICE_ADDRESS	LAS Device Address	Address of the Link Active Scheduler on the network segment.	



Rel-index	Parameter Name	Description	Help Text	Default alarm limit
26	LAS_SIGNAL_LEVEL	LAS Signal Level	Peak-to-peak signal level of the Link Active Scheduler transmissions on the network segment.	
27	LOWEST_SIGNAL_DEVICE_TAG	Lowest Signal Device Tag <i>See Note 2 on next page</i>	Tag of the device on the network segment with the lowest detected signal level in the hour.	
28	LOWEST_SIGNAL_DEVICE_ADDRESS	Lowest Signal Device Address <i>See Note 2 on next page</i>	Address of the device on the network segment with the lowest detected signal level in the hour.	
29	LOWEST_SIGNAL_LEVEL	Lowest Signal Level <i>See Note 2 on next page</i>	The lowest detected signal level at which a device transmitted in the hour.	
30	RETRANSMISSIONS	Retransmissions	Total retransmissions monitored by diagnostic module of all devices on this segment since last reset.	
31	RETRANSMISSION_RATE	Retransmission Rate	Retransmission rate = Average Retransmission Rate for all devices on this segment. <i>See Note 1 on next page</i>	
32	DEVICE_DATA_1	Device Data 1	Device address. Some fieldbus control systems display addresses as decimal so care should be taken when comparing data in the diagnostic module and the control system.  User assigned device tag. Stored in volatile memory.  Retransmissions detected by diagnostic module for this device since last reset.  Retransmission rate = Re-transmissions/pass token requests from LAS. <i>See Note 1 on next page</i>  Indicates this device is connected with the wrong polarity. Reverse wiring connections at this device.  Live device flag. The device is currently live if this is set to 1. The device is no longer live if 0.	
	DEVICE_ADDRESS	Device Address		
	DEVICE_TAG	Device Tag		
	DEVICE_SIGNAL_LEVEL	Device Signal Level		
	RETRANSMISSIONS	Retransmissions,		
	RETRANSMISSION_RATE	Retransmission Rate		
	RESERVED	Reserved		
	INVERTED_SIGNAL	Inverted Signal		
	DEVICE LIVE	Device live status		
33 - 63	As 32 for Devices 2 - 32			
64	SEGMENT_ALARMS	See Section 4.2.5.1		
65	DEVICE_ALARMS	See Section 4.2.5.2		
66	LATCHING_ALARM_ACKNOWLEDGE			
67	ALARM_ACKNOWLEDGE_REQUIRED			
68	SEGMENT_VOLTAGE_LIMITS	Segment voltage limits	Default high limit set to 32V and low limit set to 20v for F801 power supply. Set to 25V for FPS power supply and 28V for F802 power supply.	Low Low = 20V Low = 20V High = 32V High High = 32V
69	AVG_LF_NOISE_HIGH_LIMIT	Average Low Freq. Noise High Limit	Default set to 150mV	High = 150mV High High = 150mV

Rel-index	Parameter Name	Description	Help Text	Default alarm limit
70	AVG_IF_NOISE_HIGH_LIMIT	Average In-Band Freq. Noise High Limit	Default set to 75mV	High = 75mV High High = 75mV
71	AVG_HF_NOISE_HIGH_LIMIT	Average High Frequency Noise High Limit	Default set to 150mV	High = 150mV High High = 150mV
72	PEAK_LF_NOISE_HIGH_LIMIT	Peak Low Frequency Noise High Limit	Default set to 65535mV	High = 65535mV High High = 65535mV <b>See Note 3</b> (Alarm disabled)
73	PEAK_IF_NOISE_HIGH_LIMIT	Peak In-Band Frequency Noise High Limit	Default set to 65535mV	High = 65535mV High High = 65535mV <b>See Note 3</b> (Alarm disabled)
74	PEAK_HF_NOISE_HIGH_LIMIT	Peak High Frequency Noise High Limit	Default set to 65535mV	High = 65535mV High High = 65535mV <b>See Note 3</b> (Alarm disabled)
75	LIVE_DEVICE_COUNT_LIMITS	Live Device Count Limits	Default high limit set to 32 devices and low limit set to 0	Low Low = 0 Low = 0 High = 32V High High = 32V
76	DEVICE_SIGNAL_LEVEL_LIMITS_1	Device Signal Level Limits 1	After successful commissioning the device low limit may be set to 75% of current value and device high limit to 125% of current value.	Low Low = 150mV Low = 150mV High = 1200mV High High = 1200mV
77	RETRANSMISSIONS_LIMIT_1	Retransmissions Limit 1	Default set to 65535	High = 65535mV
78	RETRANSMISSION_RATE_LIMIT_1	Retransmission Rate Limit 1	Default set to 0.1%	High = 0.1%
...	As 76, 77 and 78 for Devices 2 to 31	...		
169	DEVICE_SIGNAL_LEVEL_LIMITS_32	Device Signal Level Limits 32		Low Low = 150mV Low = 150mV High = 1200mV High High = 1200mV
170	RETRANSMISSIONS_LIMIT_32_	Retransmissions Limit 32	Default set to 65535	High = 65535
171	RETRANSMISSION_RATE_LIMIT_32	Retransmission Rate Limit 32	Default set to 0.1%	High = 0.1%

Information on alarms is provided by SEGMENT\_ALARMS and DEVICE\_ALARMS.

**Note 1.** If the Identification Measurement Software version is less than 1.12 the following applies:

Updated on the first day of the month. During the first calendar month, after any device communication is identified, the value '0' will be displayed to allow sufficient pass-token requests to be monitored.

If the Identification Measurement Software version is 1.12, or later, the following applies:

The Retransmission Rate provides an excellent indicator for the quality of fieldbus segment communications. To provide an accurate Retransmission Rate, a large sample of Pass Token message replies needs to be monitored. To provide useful data at all times - even just after power is connected to the F809F, or after the retransmission counter is reset - the device calculates the retransmission rate in three phases.

- To avoid the risk of nuisance alarms during the initial phase from 1 to 5,000 Pass Tokens (typically 6 hours when 8 segments are being monitored), the displayed value will approach the actual value from below.
- During the averaging phase from 5,000 to 100,000 Pass Tokens (typically 6 days when 8 segments are being monitored) the accuracy of the displayed value increases.

- c) In normal operation, with greater than 100,000 Pass Tokens monitored, the F809F displays a moving average retransmission rate that avoids nuisance alarms from typical events whilst providing good response to changes in fieldbus communications performance.

**Note 2.** The hour means a 60 minute period starting at "the top of the hour" e.g. 0900 to 1000 or 5pm to 6pm.

**Note 3.** The device signal level high limits and peak noise high alarm limits with fieldbus software version 1.10 or earlier are:

Device Signal Level Limits - High	1000mV
Peak Low Frequency Noise	300mV
Peak In-band Frequency Noise	150mV
Peak High Frequency Noise	300mV

#### 4.2.5.1 SEGMENT\_ALARMS - Descriptions and Corrective Actions

Dec. value	Hex Value	Name and Description	Help Text
2147483648	0x80000000	Segment Voltage High-High Alarm	Check fieldbus power supply operation
1073741824	0x40000000	Segment Voltage High Alarm	
536970912	0x20000000	Segment Voltage Low Alarm	Check fieldbus power supply operation
268435456	0x10000000	Segment Voltage Low-Low Alarm	
134217728	0x08000000	Average Low Frequency Noise High-High Alarm	Check: fieldbus screening is correctly cut back and taped at each end of the fieldbus device; fieldbus screen connections are correctly made in Fieldbus Barrier Junction Box, intermediate junction boxes, in marshalling cabinet, FP32 surge protector and connected to F618D and grounding connection of F618D; AC cabling close to fieldbus cabling; wire terminations are properly secured.
67108864	0x04000000	Average Low Frequency Noise High Alarm	
33554432	0x02000000	Average In Band Frequency Noise High-High Alarm	Check: fieldbus screening is correctly cut back and taped at each end of the fieldbus device; fieldbus screen connections are correctly made in Fieldbus Barrier Junction Box, intermediate junction boxes, in marshalling cabinet, FP32 surge protector and connected to F618D and grounding connection of F618D; AC cabling close to fieldbus cabling; wire terminations are properly secured. Check for welding on plant or poor grounding of frequency controlled drives.
16777216	0x01000000	Average In Band Frequency Noise High Alarm	
8388608	0x00800000	Average High Frequency Noise High-High Alarm	Check: for sources of high frequency noise such as welding on plant, poor grounding of frequency controlled drives.
4194304	0x00400000	Average High Frequency Noise High Alarm	
2097152	0x00200000	Peak Low Frequency Noise High-High Alarm	If frequent alarms, check: fieldbus screening is correctly cut back and taped at each end of the fieldbus device; fieldbus screen connections are correctly made in Fieldbus Barrier Junction Box, intermediate junction boxes, in marshalling cabinet, FP32 surge protector and connected to F618D and grounding connection of F618D; AC cabling close to fieldbus cabling; wire terminations are properly secured.
1048576	0x00100000	Peak Low Frequency Noise High Alarm	
524288	0x00080000	Peak In Band Frequency Noise High-High Alarm	If frequent alarms, check: for operation of radios with Effective Radiated Power (ERP) of up to 5W being used within 1.5m of fieldbus devices, junction box or cabling; fieldbus screening is correctly cut back and taped at each end of the fieldbus device; fieldbus screen connections are correctly made in Fieldbus Barrier Junction Box, intermediate junction boxes, in marshalling cabinet, FP32 surge protector and connected to F618D and grounding connection of F618D; AC cabling close to fieldbus cabling; wire terminations are properly secured. Check for welding on plant or poor grounding of frequency controlled drives.
262144	0x00040000	Peak In Band Frequency Noise High Alarm	
131072	0x00020000	Peak High Frequency Noise High-High Alarm	If frequent alarms, check: for operation of radios with Effective Radiated Power (ERP) of up to 5W being used within 1.5m of fieldbus devices, junction box or cabling; for welding on plant or poor grounding of frequency controlled drives.
65536	0x00010000	Peak High Frequency Noise High Alarm	
32768	0x00008000	Live Device Count High Alarm	Check if additional device has been added to segment, if new device is approved and segment documentation has been updated, reset live device count limits;

Dec. value	Hex Value	Name and Description	Help Text
16384	0x00004000	Live Device Count Low Alarm	If alert not cleared immediately on acknowledgement, check for device failed or removed for maintenance. If alert cleared immediately on acknowledgement, this is an indication of intermittent communication. Check trunk cabling, host and trunk JB connections are tight; for water in trunk or spur cable, junction boxes; host operation; spur cabling, spur and device connections are tight; for water in device; for device operation.
8192	0x00002000	+ve short to shield	Check: fieldbus screening is correctly cut back and taped at each end of the fieldbus device; fieldbus screen connections are correctly made in Fieldbus Barrier Junction Box, intermediate junction boxes, in marshalling cabinet, FP32 surge protector and connected to F618D and grounding connection of F618D. Disconnect portions of cable and check if the short goes away. Verify the fieldbus power supply is isolated from ground. Check for damaged or waterlogged cable, junction box or device.
4096	0x00001000	-ve short to shield	
2048	0x00000800	32 device addresses used	Check if any devices will no longer be used on the segment and delete history of these devices.

#### 4.2.5.2 DEVICE\_ALARMS - Descriptions and Corrective Actions

Dec. value	Hex Value	Name and Description	Corrective Action
32768	0x8000	Device Signal Level High-High Alarm	If only one device high: check alarm limits have not been wrongly set, check device operation. If several/all devices on segment check for only one terminator on segment or failed terminator.
16384	0x4000	Device Signal Level High Alarm	
8192	0x2000	Device Signal Level Low Alarm	If only one device low: check alarm limits have not been wrongly set, check spur cabling, spur and device connections are tight, water in spur cable or device, check device operation. If several/all devices on segment low check for more than two terminators on segment, check for water in devices, junction boxes and cabling.
4096	0x1000	Device Signal Level Low-Low Alarm	
2048	0x0800	Retransmissions High Alarm	Check retransmission limit has not been wrongly set. Check retransmission rate. Check for changes in parameter levels compared to values at commissioning and with history. Investigate any significant changes.
1024	0x0400	<i>Retransmission Rate High-High Alarm</i>	<i>Reserved for future use</i>
512	0x0200	Retransmission Rate High Alarm	This is an excellent key performance indicator of device communication health. Check retransmission rate limit has not been wrongly set. Check for changes in parameter levels compared to values at commissioning and with history. Investigate any significant changes. If only one device check spur cabling, spur and device connections are tight, Check for water in spur cable or device, check device operation. If all/several devices on segment check trunk cabling, host and trunk JB connections are tight, check for water in trunk or spur cable, junction boxes or all devices, check host operation.

#### 4.2.5.3 DEVICE\_ALERTS - Descriptions

These alerts are useful during commissioning and maintenance. To avoid high levels of alarms, these alerts do not set the "BLOCK\_ERR needs maintenance soon" bit, the "DI block alarm" or the segment LED to "flashing". On an operational fieldbus segment, these events can be set to generate alarms - if required, by configuring "segment device count" low and high alarms.

Value	Name	Description
0x0100	New Device	When new device is added to segment, this alert is displayed for one hour. It does not set the "Device needs maintenance soon" bit.
0x0080	Device Removed	When an established device is removed from a segment, this alert is displayed for one hour. It does not set the "Device needs maintenance soon" bit.

### 4.3 Discrete Input Block

The discrete input blocks calculate their PV\_D value from the current values of the alarm parameters of the transducer blocks and calculate the OUT\_D value according to the Discrete Input Block algorithm.

**Alarm DI Block:** PV\_D will be set to 1 if any of the System Alarm, Segment / Device Alarm or Self Test Fault Alarm bits is set. Selected by channel value 12.

**System Alarm DI Block:** PV\_D will be set to 1 if any System Alarm and Self Test Fault Alarm bits are set. Selected by channel value 13.

**Segment Alarm DI Block 1 – 8:** PV\_D will be set to 1 if any of the Segment / Device Alarm bits is set for the resp. segment. Selected by channel values 14 – 21 for segments 1 – 8.

The selection, which summarized alarm is displayed in which DI function block is adjustable through the CHANNEL parameter of the function block. The default value of the CHANNEL parameter (valid values are 12 to 21) pre-selects the various types of alarms as described above.

Channels Summary:	Channel	Description
	12	Alarm DI Block
	13	System Alarm DI Block
	14	Segment 1 Alarm DI Block
	15	Segment 2 Alarm DI Block
	16	Segment 3 Alarm DI Block
	17	Segment 4 Alarm DI Block
	18	Segment 5 Alarm DI Block
	19	Segment 6 Alarm DI Block
	20	Segment 7 Alarm DI Block
	21	Segment 8 Alarm DI Block

For applications using DI Blocks to communicate alarms to the host system, configure the links between the function blocks and schedule the order of their execution.

#### 4.3.1 Discrete Input Block Errors

The following conditions are reported in the BLOCK\_ERR parameters. Conditions in **bold** are supported in the DI blocks.

**Table 4-6.** Block/Transducer Error

##### BLOCK\_ERR

Condition Number	Name and Description
0	Other
1	Block configuration error
2	Link configuration error
3	Simulate active
4	Local override
5	Device fault state set
<b>6</b>	<b>Device needs maintenance soon</b>
<b>7</b>	<b>Input failure</b>

## 5 OPERATION AND MAINTENANCE

### 5.1 LED indicators

#### Power status (green)

- ON** power on
- OFF** power fail

#### Segment status (amber)

- ON** segment monitored
- OFF** segment not monitored
- FLASHING** active segment alarm

### 5.2 FOUNDATION Fieldbus Information

FOUNDATION fieldbus™ is an all-digital, serial, two-way, multidrop communication protocol that interconnects devices such as transmitters and valve controllers. It is a local area network (LAN) for instruments that enables basic control and I/O to be moved to the field devices. The model F809F uses FOUNDATION fieldbus technology developed and supported by MTL and the other members of the independent Fieldbus Foundation.

#### 5.2.1 Commissioning (Addressing)

To be able to setup, configure, and have it communicate with other devices on a segment, a device must be assigned a permanent address. Unless requested otherwise, it is assigned a temporary address when shipped from the factory.

If there are two or more devices on a segment with the same address, the first device to start up will use the assigned address (ex. Address 20). Each of the other devices will be given one of the four available temporary addresses. If a temporary address is not available, the device will be unavailable until a temporary address becomes available.

Use the host system documentation to commission a device and assign a permanent address.

### 5.3 Hardware Maintenance

The F809F has no moving parts and requires a minimal amount of scheduled maintenance. If a malfunction is suspected, check for an external cause before performing the diagnostics presented below.

#### 5.3.1 Communication/Power Check

If the Fieldbus Diagnostic Module does not communicate, or provides an erratic output, check for adequate voltage to it. The F809F requires between 9.0 and 32.0V DC on the communicating fieldbus segment. This is selected as Segment 1 or 8 of the monitored segment or a separate fieldbus segment. Check for wire shorts, open circuits, and multiple grounds on the communicating fieldbus segment.

#### 5.3.2 Resetting the Configuration (RESTART)

The Restart Processor parameter in the Resource Block offers the choice of:

- a) a) an uninitialised restart that restarts the processor with the current configuration, or
- b) b) a default restart that restores the default configuration.

Following a default restart the block is in OOS Mode. The block must be manually placed back into Auto Mode.

**Note**, for FBK versions prior to 1.30 a Processor Restart must be performed to return block to Auto Mode.

- a) c) Restart resource, is accepted, but no function executed.
- b) d) Run is the normal state for the block. To clear field after a Processor restart the parameter should be manually set to Run with some systems.
- c) e) Restart processor will trigger an immediate reset of the processor. As the F809F does not acknowledge the request this may cause an error message with some systems.

## 5.4 Troubleshooting

### 5.4.1 Foundation Fieldbus

Symptom	Possible Cause	Corrective Action
Device does not show up in the live list	Network configuration parameters are incorrect	Set the network parameters of the LAS (host system) according to the FF Communications Profile: ST: 8 MRD: 10 DLPDU PhLO: 4 MID: 7 TSC: 4 (1 ms) T1: 1920000 (60 s) T2: 5760000 (180 s) T3: 480000 (15 s)
	Network address is not in polled range.	Set first Unpolled Node and Number of UnPolled Nodes so that the device address is within range.
	Power to the device is below the 9 VDC minimum.	Increase the power to at least 9V.
	Noise on the power / communication is too high.	Verify terminators and power conditioners are within specification Verify that the shield is properly terminated and not grounded at both ends. It is best to ground the shield at the power conditioner.
Device that is acting as a LAS does not send out CD	LAS Scheduler was not downloaded to the Backup LAS device	Ensure that all of the devices that are intended to be a Backup LAS are marked to receive the LAS schedule
All devices go off live list and then return	Live list must be reconstructed by Backup LAS device	Current link setting and configured links settings are different. Set the current link setting equal to the configured settings.

### 5.4.2 Resource Block

Symptom	Possible Cause	Corrective Action
Mode will not leave OOS	Target mode not set Memory Failure	Set target mode to something other than OOS. BLOCK_ERR will show the lost NV Data or Lost Static Data bit set. Restart the device by setting RESTART to Processor. If the block error does not clear, call the factory.
Block Alarms Will not work	Features Notification	FEATURES_SEL does not have Alerts enabled. Enable the report bit. LIM_NOTIFY is not high enough. Set equal to MAX_NOTIFY.

### 5.4.3 System and Segment Transducer Block Troubleshooting

Symptom	Possible Cause	Corrective Action
Mode will not leave OOS	Target mode not set Resource block	Set target mode to AUTO The actual mode of the Resource block in OOS. See Resource Block Diagnostics for corrective action

## APPENDIX A: TROUBLESHOOTING TABLE

<b>Symptom</b>	<b>Possible Causes</b>
<b>High peak or average noise</b>	Water/condensation in wiring, improperly connected shield, bad fieldbus device, bad physical layer component (power supply, terminator, wiring block), segment is not isolated from ground, fieldbus cable is located near noise producing cable, loose wire termination.
<b>Recommendations:</b> Inspect the network cable and connections. Tighten screw terminals and connector hold-down screws. Look for waterlogged cables, condensation in junction boxes, loose wires, FF cable routed near other signaling cables or AC power cables, loose strands of wire shorting to other wires/conductive objects. Check if fieldbus to shield short is present and if so follow recommendations below. Verify the segment is powered by an isolated fieldbus power supply or that the bulk supply for the fieldbus power supply is isolated and only powers one segment. Take noise measurements at multiple locations on the network to identify where noise is highest and most likely located. Measure resistance from shield to ground with a DMM and verify it is <100Ω. Disconnect devices one at a time to see if noise disappears. Replace terminators, fieldbus power supplies, and wiring blocks.	
<b>Symptom</b>	<b>Possible Causes</b>
<b>Excessive retransmissions rate (on one device)</b>	Bad spur wiring connection to device, not enough power to the device, bad device, bad port on the wiring block, noise on the spur.
<b>Recommendations:</b> Check if high noise levels are present and if so follow recommendations above. If the wiring block has a current limiting (SpurGuard) feature, check the associated LED to make sure it isn't constantly or intermittently lit. Inspect the wiring and connections from the wiring block to the device looking for waterlogged cables, condensation in junction boxes, loose wires, FF cable routed near other signaling cables or AC power cables, loose strands of wire shorting to other wires/conductive objects. Try putting the device on a different spur from the wiring block. Replace the device.	
<b>Symptom</b>	<b>Possible Causes</b>
<b>Excessive retransmissions rate (on all or multiple devices)</b>	Wiring problem, not enough power to the devices, bad physical layer device (power supply, terminator, wiring block), noise on the bus
<b>Recommendations:</b> Determine if the entire network is affected or just part of it. Focus on the part of the network with problems. Check if high noise levels are present and if so follow recommendations above. Use the FBT-3/6 to check for high noise levels at the device and check the bus voltage is >9VDC at the device furthest from the power supply. Inspect the network looking for waterlogged cables, condensation in junction boxes, loose wires, FF cable routed near other signaling cables or AC power cables, loose strands of wire shorting to other wires/conductive objects. Replace the terminators, power supply/conditioner.	
<b>Symptom</b>	<b>Possible Causes</b>
<b>Low device signal level (one device)</b>	Bad spur wiring connection to device, not enough power to the device, bad device, bad port on the wiring block
<b>Recommendations:</b> Use FBT-3/6 to check the voltage at the device is >9VDC. If the wiring block has a current limiting (SpurGuard) feature, check the associated LED to make sure it isn't constantly or intermittently triggered. Inspect the wiring and connections from the wiring block to the device looking for waterlogged cable, condensation, loose wires, loose strands of wire shorting to other wires/conductive objects. Verify the maximum length of cable between any 2 devices does not exceed 1900m and spur length does not exceed 120m. Try connecting the device on a different spur from the wiring block. Replace the device.	
<b>Symptom</b>	<b>Possible Causes</b>
<b>Low device signal level (all devices)</b>	Wiring problem, not enough power to the devices, bad physical layer device (power supply, terminator, wiring block)
<b>Recommendations:</b> Use FBT-3/6 to check the voltage at the device furthest from it is >9VDC. Check the power LEDs on the wiring blocks are steadily lit. Inspect the wiring and connections (especially at the parts common to all devices such as power supply/conditioner, terminators, trunk cable, etc.) looking for waterlogged cable, condensation, loose wires, loose strands of wire shorting to other wires/conductive objects. Replace suspect physical layer components (power supply/conditioner, terminators, wiring blocks).	
<b>Symptom</b>	<b>Possible Causes</b>
<b>High device signal level (one device)</b>	Bad device
<b>Recommendations:</b> Replace the device.	
<b>Symptom</b>	<b>Possible Causes</b>
<b>High device signal level (all devices)</b>	Missing terminator, failed terminator, improperly connected terminator, failed fieldbus power supply
<b>Recommendations:</b> Verify two terminators are installed (note that some terminators are built-in to power supplies/conditioners and wiring blocks, some are turned on/off with a switch and some are automatic). Check wiring to the terminators. Replace suspect terminators or the products that contain them. Replace the fieldbus power supply.	



**Symptom****Possible Causes****Shield short to fieldbus**

Wiring problem, un-isolated device connected to the fieldbus, water in a cable/device/wiring block

**Recommendations:** Check for damaged cable, make sure all devices are properly connected. Verify that fieldbus is not connected to a ground at the power supply or to a device case. Look for shield connections to the fieldbus cable including stray strands of wire at wire terminations or un-insulated shield wire loose at the device. Disconnect portions of cable and check if the short goes away. Verify the fieldbus power supply is isolated from ground.

---

**Symptom****Possible Causes****Device is not "seen" on the bus/not communicating**

Bad spur wiring connection to device, not enough power to the device, bad device, bad port on the wiring block

**Recommendations:** Check DC voltage at the device is >9VDC. If the wiring block the device is connected to has a current limiting (SpurGuard) feature, check the associated LED to make sure it isn't constantly or intermittently triggered. Inspect the wiring and connections from the wiring block to the device looking for waterlogged cable, condensation, loose wires, loose strands of wire shorting to other wires/conductive objects. Try putting the device on a different spur from the wiring block. Replace the device.

---





**MTL Instruments Pty Limited**

1/30 Canvale Road  
Canning Vale  
Perth, WA 6155  
Australia  
Tel: +61 (0)8 9455 2994 Fax: +61 (0)8 9455 2805  
E-mail: enquiries@mtlaus.com.au

**MTL Canada Safety Instrumentation**

#102, 4249 97 Street  
Edmonton, Alberta  
Canada T6E 5Y7  
Tel: +1 780 485 3132 Fax: +1 780 485 3122  
E-mail: cinfo@mtlnh.com

**MTL Instruments China Co. Ltd.**

Room 1002A, The Gateway  
No 10 Yabao Road, Chaoyang District  
Beijing 100020  
China  
Tel: +86 010 8562 5718/5720/5721 Fax: +86 010 8562 5725  
E-mail: bjsales@mtl-inst.cn

**MTL Instruments sarl**

Les Carrés du Parc  
10 rue des Rosiéristes  
69410 Champagne au Mont d'Or  
France  
Tel: +33 (0)4 78 64 98 32 Fax: +33 (0)4 78 35 79 41  
E-mail: info@mtl-inst.fr

**MTL Instruments GmbH**

An der Gumpgesbrücke 17  
D-41564 Kaarst  
Germany  
Tel: +49 (0)2131 718930 Fax: +49 (0)2131 7189333  
E-mail: info@mtl.de

**MTL India**

No. 36, Nehru Street  
Off Old Mahabalipuram Road  
Sholinganallur  
Chennai - 600 119  
India  
Tel: + 91 (0)44 24501660/24501857 Fax: + 91 (0)44 24501463  
E-mail: sales@mtlindia.com

**MTL Italia srl**

Via Cantù 11  
I - 20092 Cinisello Balsamo MI  
Italy  
Tel: +39 (0)2 61802011 Fax: +39 (0)2 61294560  
E-mail: info@mtl-inst.it

**MTL Instruments KK**

3rd Floor, Gotanda Masujima Building  
1-8-13 Higashi-Gotanda, Shinagawa-Ku  
Tokyo 141-0022  
Japan  
Tel: +81 (0)3 5420 1281 Fax: +81 (0)3 5420 2405  
E-mail: sales@mtlkk.co.jp

**MTL Instruments BV**

PO Box 55, 6680 AB Bommel  
de Houtakker 36, 6681 CW Bommel  
The Netherlands  
Tel: +31 (0)481 450250 Fax: +31 (0)481 450260  
E-mail: info@mtlbenelux.com

**MTL Instruments Pte Limited**

31 Ubi Road 1  
#04-01 Aztech Building  
Singapore 408694  
Tel: +65 6 487 7887 Fax: +65 6 487 7997  
E-mail: sales@mtlsing.com.sg

**MTL Instruments**

Villa No. 4, Sector 2-17, Street 6  
PO Box 53234,  
Abu Dhabi, UAE  
Tel: +971 2 446 6840 Fax: +971 2 446 6841  
E-mail: mtlgulf@mtl-inst.com

**Measurement Technology Limited**

Power Court, Luton, Bedfordshire  
England LU1 3JJ  
Tel: +44 (0)1582 723633 Fax: +44 (0)1582 422283  
E-mail: enquiry@mtl-inst.com

**MTL Incorporated**

4001 W. Sam Houston Parkway N., Suite 150  
Houston TX 77043  
USA  
Tel: +1 281 571 8065 Fax: +1 281 571 8069  
E-mail: info@mtl-inst.com

