

# 9108-22

*4-segment, redundant FISCO power supply system  
for Yokogawa CENTUM CS 3000 Control Systems*



**Instruction Manual**

**INM9108**





# CONTENTS

- 1 OVERVIEW . . . . . 1**
- 2 DESCRIPTION . . . . . 1**
  - 2.1 Architecture . . . . . 1**
  - 2.2 Module carrier . . . . . 3**
- 3 INSTALLATION . . . . . 3**
  - 3.1 General . . . . . 3**
  - 3.2 Required tools . . . . . 3**
  - 3.3 Mounting overview . . . . . 3**
  - 3.4 Surface mounting . . . . . 5**
  - 3.5 Mounting Power Supply & SAM modules . . . . . 5**
- 4 ELECTRICAL INSTALLATION . . . . . 6**
  - 4.1 Redundant Power Connections . . . . . 6**
  - 4.2 Alarm Connections . . . . . 6**
  - 4.3 Hazardous-Area Fieldbus Segment Connections . . . . . 7**
  - 4.4 Control System Cable Connections . . . . . 8**
- 5 TESTING AND FAULT FINDING . . . . . 8**
  - 5.1 Testing . . . . . 8**
  - 5.2 Manual Failover testing . . . . . 8**
  - 5.3 LED Indicators . . . . . 9**
- 6 APPENDIX : ATEX CERTIFICATION INFORMATION . . . . . 10**
  - 6.1 General . . . . . 10**
  - 6.2 Installation . . . . . 10**
  - 6.3 Inspection and maintenance . . . . . 10**
  - 6.4 Repair . . . . . 10**
  - 6.5 Marking . . . . . 10**

## GENERAL SAFETY INFORMATION

### Safety instructions for installation and operating personnel

See **Appendix on ATEX certification** for countries in EEC, or governed by these standards.

The operating instructions provided here contain **essential safety instructions** for installation personnel and those engaged in the operation, maintenance and servicing of the equipment.

#### WARNING

**Failure to comply with these instructions can endanger the lives or health of personnel and risk damage to the plant and the environment.**

#### WARNING

**The responsibility for planning, installation, commissioning, operation and maintenance, particularly with respect to applications in explosion-hazard areas, lies with the plant operator.**

#### Before commencing installation or commissioning:

- ◆ *Read and understand the contents of this manual*
- ◆ *Ensure installation and operating personnel have received adequate training for this task*
- ◆ *Ensure that any operating instructions are fully understood by the personnel responsible.*

#### WARNING

**These assemblies may not be used in explosion-hazard area applications if they have been used previously in general electrical installations.**

- ◆ *Observe national and local installation and mounting regulations (e.g. IEC 60079-14).*

#### During operation:

- ◆ *Make the relevant instructions available at all times to the operating personnel.*
- ◆ *Observe safety instructions.*
- ◆ *Observe national safety and accident prevention regulations.*
- ◆ *Operate the equipment within its published specification.*
- ◆ *Servicing, maintenance work or repairs not described in this manual must not be performed without prior agreement with the manufacturer.*
- ◆ *Any damage to this equipment may render its explosion protection null and void.*
- ◆ *No changes to any of the components that might impair their explosion protection are permitted.*

#### If any information provided here is not clear:

- ◆ *Contact MTL or one of its representatives.*

**Note:** Improper installation and operation of the enclosure can result in the invalidation of the guarantee.

### Related documents

Datasheets	Description
<b>EPS9108-22</b>	4-segment, redundant, FISCO power supply system for Yokogawa CENTUM CS3000 Control Systems

**Figure 1.1  
9108-22  
power supply  
assembly**



## **1 OVERVIEW**

The 9108-22 system is specifically designed for connection to Yokogawa CENTUM CS 3000 control systems equipped with ALF111 FOUNDATION fieldbus™ communication modules. It provides intrinsically safe power for four FOUNDATION fieldbus™ H1 segments in Gas Groups IIB hazardous areas. The output of the power supply modules complies with the Fieldbus Intrinsically Safe Concept (FISCO) model, in accordance with IEC standard 60079-27 Edition 2.0 (2008). The key advantages of FISCO over earlier 'Entity' model installations to FF-816 are higher available field current and reduced safety documentation, while retaining the ability to conduct maintenance while energised and without 'gas clearance'.

The 9108-22 system uses MTL's proven 9122-IS Series power supplies, which have become established as the industry standard solution for FISCO networks. The 9108-22 system delivers even higher levels of overall system availability by providing redundancy of the power modules.

When used with intrinsically safe versions of MTL-Relcom *Megablock* field wiring hubs, the power supply system allows complete FISCO networks to be assembled for even the most demanding process applications.

This manual provides information for the installation and maintenance of the 9108-22 redundant FISCO power supply. The datasheet part number for this model is shown on the opposite page.

## **2 DESCRIPTION**

### **2.1 Architecture**

Each of the four fieldbus segments receives its power from a redundant pair of pluggable FISCO power supply modules- see Figure 2.1. These power supply modules operate in active/hot standby mode, ensuring that the fieldbus segments are continually powered.

In the event of the failure of the *active* power supply module output, the field circuit is automatically transferred to the standby module. The change-over is managed by Supply Arbitration Modules (SAMs), which monitor the health of the FISCO power supplies while maintaining intrinsic safety requirements during the transition to the standby module. The SAMs are also duplicated and replaceable, meaning that there are no non-redundant system components.

Switch-over is achieved rapidly and in accordance with FOUNDATION fieldbus™ specifications, and without risk of losing fieldbus devices from the bus. A combination of LED diagnostics and alarm signalling provides failure notification of FISCO power supplies and SAMs, allowing failed hardware to be identified and full redundancy to be restored by module replacement.

**Figure 2.1**  
**9108-22**  
**architecture**  
**per segment**

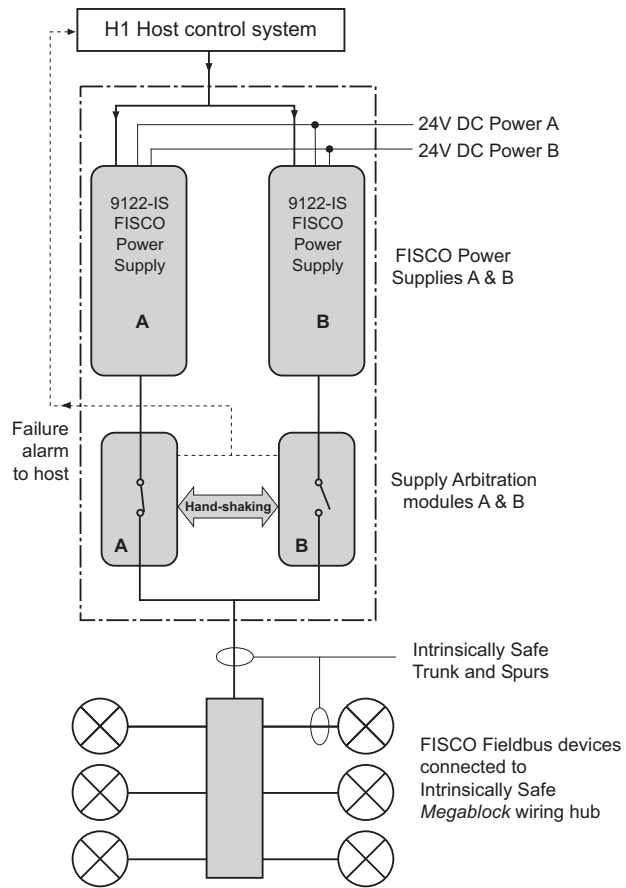

**Figure 2.2**  
**9108-22**  
**assembly**  
**dimensions**

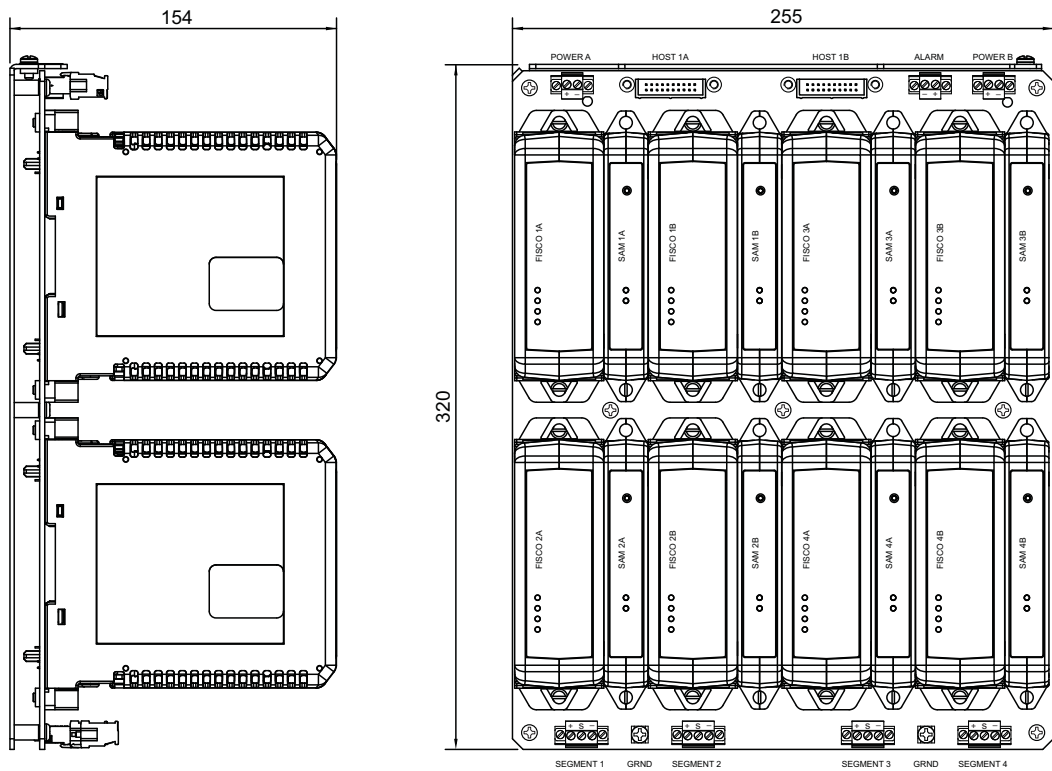

## 2.2 Module carrier

The module carrier provides fieldbus power for four fieldbus segments. It supports a pair of redundant pluggable power supply and arbitration modules for each segment and all connection facilities.

Each carrier has connections for redundant 24V input power supplies, ALF111 fieldbus communication modules via AKB336 cables and intrinsically safe field trunks. A volt-free failure alarm is also provided for connection to a digital input module in the host control system. There are no active electronic circuits on the carrier, resulting in long calculated Mean Time to Failure (MTTF) and overall high system availability.

The carrier dimensions (Figure 2.2) are designed to provide high packing density in typical 800mm wide equipment cabinets. Survival in high-vibration marine environments is achieved by secure panel-mount fixings.

The FISCO power supply modules are pluggable versions of MTL's established 9122-IS units applications, and support the same level of features. These include a built-in repeater function for accurate wave-shape transmission and communication error reduction, and three-way isolation between bulk power, host and field trunks for elimination of cross-talk between segments. LED indicators provide information on system health and assist with fault diagnosis.

## 3 INSTALLATION

**WARNING:** This equipment must be installed, operated and maintained only by trained competent personnel and in accordance with all appropriate international, national and local standard codes of practice and site regulation for intrinsically safe apparatus and in accordance with the instructions contained here.

### 3.1 General

The 9108-22 power system may be mounted in a safe area or a Zone 2 IIB T4 hazardous area. See also *Section 6 - Appendix* for further information. The mounting conditions must:

- a. prevent any form of pollution that could compromise the operation of the unit. For example, an unpolluted location or a suitable enclosure could be chosen.
- b. provide an adequate level of mechanical protection. This can be achieved by selecting a protected location, a suitable cabinet or enclosure, or a combination of both.
- c. ensure that all cable entries and connections are secure by making provision for the careful routing and securing of all cables.
- d. provide adequate security against unauthorised interference.
- e. ensure that the permitted ambient temperature range of the units (-20°C to +60°C) is not exceeded. Be aware of the power dissipation in the equipment's cabinet or enclosure and consider the use of shading against direct sunlight, or even forced cooling.

### 3.2 Required tools

To remove or replace a FISCO or a SAM module a straight-bladed screwdriver is required with a minimum shaft length of 130mm (5¼") and a maximum blade diameter of 5mm (3/16").

### 3.3 Mounting overview

Mount the 9108-22 assembly on a vertical surface with the orientation shown in Figure 2.2. Any other orientation will reduce the permitted maximum operating temperature.

**IMPORTANT:** The mounting surface and any fixings must be capable of supporting the weight of the complete assembly which is just under 5.5kg.

Four 7mm diameter slotted holes are provided in the backplate for mounting the assembly - see Figure 3.1 - and access to the mounting screws is provided through the circuit board (after removal of some modules). This feature allows the assembly to be fitted to, or removed from, its mounting without removing the mounting screws.

**Note:** Because of the slotted mounting holes, 15mm of free space is required above the top edge of the assembly to allow the backplate to be mounted and demounted.

**Figure 3.1**  
Baseplate  
mounting  
holes

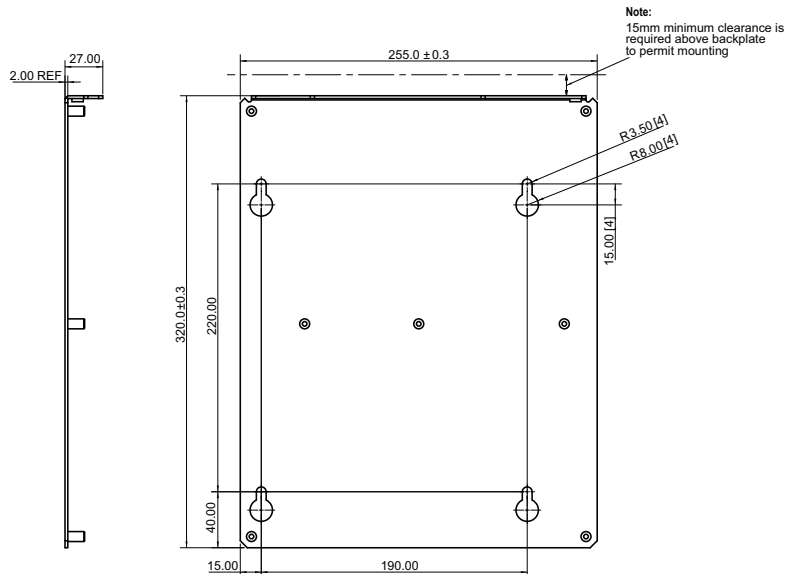

**Figure 3.2**  
9122-IS-CM  
power supply  
module  
dimensions

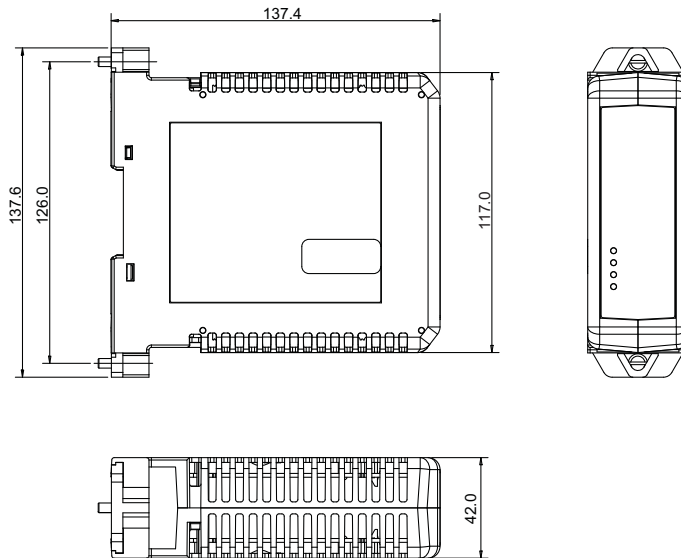

**Figure 3.3**  
9129-IS  
Supply  
Arbitration  
Module (SAM)  
dimensions

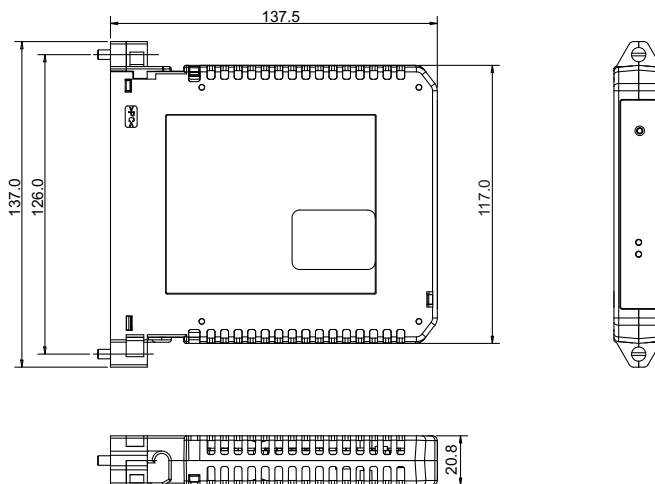

### 3.3.1 Outdoor mounting

If the assembly is to be mounted in an outdoor location, a suitable enclosure with a minimum of IP54 ingress protection is required. However, in some locations, a higher degree of ingress protection rating is recommended as corrosion resistance may be necessary or desirable and the emphasis should be placed on the suitability for the application.

### 3.4 Surface mounting

Prepare holes in the mounting surface at the centres shown in Figure 3.1. Thread the holes M6 or fit M6 captive nuts as required.

The recommended fixing method for this assembly uses M6 Sems screws; or some similar captive washer screw assembly. Alternatively, take four M6 screws - recommended minimum length 15mm - and fit a locking washer and a plain washer on each.

Start the screws into the surface fixing holes, leaving approximately 10mm clear thread visible.

With all modules removed from the assembly, fit the backplate, and its attached circuit board, over the four screw-heads (and washers) and allow it to rest on the four screws. Tighten the four screws to a minimum torque of 4 Nm, to secure the backplate to the mounting surface.

### 3.5 Mounting Power Supply & SAM modules

#### CAUTION!

Fitting or removal of modules must not be performed in a hazardous area or environment without first isolating the supply.

The SAM module has a mechanical safety interlock to prevent it from being removed before its associated power supply; this is so that the segment power stays in a safe and predictable state. This interlock must not be removed or defeated in any way.

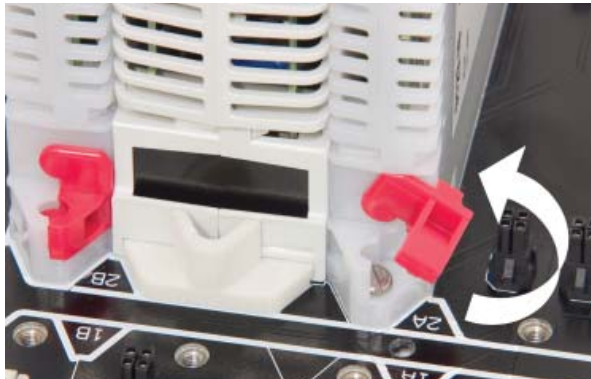

**Figure 3.4**  
**SAM module**  
**interlock tab**

#### 3.5.1 Fitting modules

The SAM module must be fitted before its related FISCO power supply module.

1. Rotate the red interlock tab on the SAM module to the side and up to reveal the fixing screw head. See Figure 3.4.
2. Locate the SAM module in its position and tighten both of its fixing screws.
3. Return the interlock tab to cover the screw head. See Figure 3.4
4. Locate the FISCO power supply module to the left of the SAM module and tighten both of its fixing screws.
5. Repeat 1 - 4 for the other module pairs, as required.

**Note:** If a FISCO power supply module position is left vacant it will cause an alarm condition to be signalled at the **Alarm** contacts. To prevent this a 9127-BLK blanking module can be fitted in the position normally occupied by the associated SAM module. See Section 4.2.1 for further details.

### 3.5.2 Removing modules

The FISCO power supply module must be removed before its related SAM module.

1. Loosen the two fixing screws of the FISCO power supply module and remove it from the circuit board.
2. Slide the red interlock tab on the SAM module to the side to reveal the fixing screw head. See Figure 3.4
3. Loosen the two fixing screws of the SAM module and remove it from the circuit board.
4. Repeat 1 - 3 for the other module pairs, as required.

## 4 ELECTRICAL INSTALLATION

### 4.1 Redundant Power Connections

The POWER A and POWER B connectors receive the redundant 19.2 - 30V input power supplies. These connectors are keyed to prevent insertion into the Alarm socket on the carrier. Correct operation requires both input power supplies to be present in order to avoid an alarm signal being generated.

**Note:** To comply with product certification, both power connections are required to have their connector plugs in place - see Power B in Figure 4.1 - and Section 6 - Appendix.

Each input power supply must be able to support, independently, the power requirements of four fieldbus segments; which, with a power supply voltage of 24V and with all four running at maximum load requires a total current of 2.5A .

The user may determine how many 9108-22 assemblies are operated from each bulk power supply, but adequate protective fusing is recommended to protect both the supplies and the assemblies.

Connect the incoming power supplies to the POWER A and POWER B screw terminal connectors at the top edge of the assembly circuit board. See Figure 2.2. Observe the supply polarities indicated beside the connectors on the circuit board. See Figure 4.1.

**Figure 4.1**  
**POWER B**  
**and ALARM**  
**connectors**

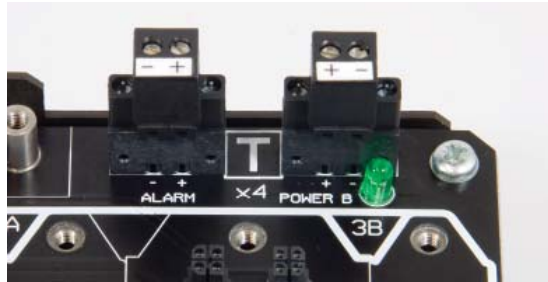

#### 4.1.1 Backplate Grounding

A separate connection must be made from the ground terminal provided on the backplate to the enclosure's protective ground to ensure that the backplate is in good electrical contact with the enclosure and its protective ground.

### 4.2 Alarm Connections

Each SAM module contains a solid state switch that is 'closed' in **normal operation** and exhibits in this condition a maximum resistance of 45Ω. If a SAM module recognises a fault condition its switch will 'open' and present a resistance in excess of 1MΩ.

The eight SAM modules (two per segment) are all *connected in series* and the ends presented at the ALARM connector at the top edge of the module carrier - See Figure 4.1. In normal operation, therefore, the ALARM terminals on the module carrier will present a nominal resistance value of 360Ω.

**Figure 4.2**  
**Daisy-chaining**  
**ALARM circuits**

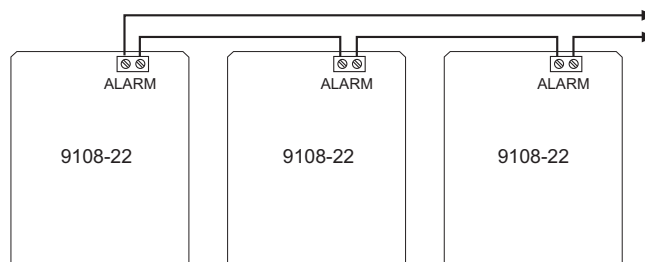

If required, the alarm circuits of a number of 9108-22 assemblies can be daisy-chained to present a single alarm signal. See Figure 4.2. In order to do this, the digital input module being used to receive the alarm signal must be able to recognise the total series resistance of all the carriers as a normal 'closed' condition. For example, three carriers connected in series will present a series resistance in the 'closed' condition of around 1080Ω.

**Notes:**

1. Although the Alarm terminals on the module carrier are marked '+' and '-' to aid identification, the solid state alarm circuits are polarity insensitive.
2. The Alarm connector is keyed to prevent it being inserted into a Power socket on the board.
3. For the alarm circuit to operate correctly, (i.e. for the solid state switches to go to a 'closed' condition), all eight FISCO power supply and SAM modules must be installed on the module carrier.
4. To comply with product certification, the Alarm connector plug must be in place - see Figure 4.1 and Section 6 - Appendix.

**4.2.1 9127-BLK blanking module**

If a FISCO power supply module is omitted or removed from the 9108-22 backplane, its SAM module will automatically trigger the alarm circuit, as described above. To avoid this, a 9127-BLK blanking module is available, which is the same size and shape as a SAM, and should be used in place of the SAM module to maintain alarm circuit continuity and prevent the creation of an alarm.

In addition, it is important that a 9127-BLK blanking module is fitted in every *unused* SAM location on the carrier in order to allow the system to recognise alarms from the *active* modules fitted.

**4.3 Hazardous-Area Fieldbus Segment Connections**

The intrinsically safe segment power output connections are provided via 3-way, pluggable, rising cage clamp, screw terminals at the bottom edge of the 9108-22 module carrier. See Figure 2.2 and 4.3.

Prepare the cables and connect to the +ve and -ve terminals as indicated on the pluggable connectors.

**Figure 4.3**  
Segment  
connectors and  
ground/shield  
stud

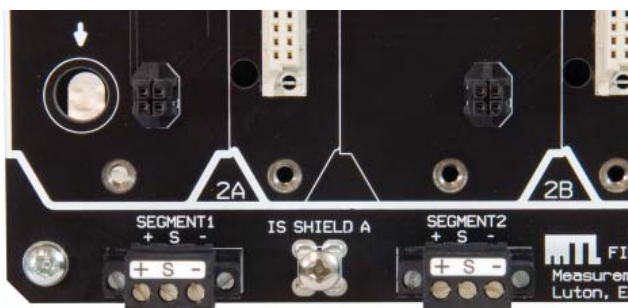

**Note:** It is important during installation to **segregate intrinsically safe wiring from other non-intrinsically safe wiring** and to mark it clearly as intrinsically safe.

Two ground studs (IS Shield A and IS Shield B) are provided on the module carrier, adjacent to the hazardous area field wiring connections. These provide a means of grounding the cable screens/shields of the intrinsically safe field cables carrying the fieldbus trunks. If they are to be used to ground the field cable shields, the following procedure should be adopted:

- Connect the shield of each field cable to the 'S' terminal on its 3-way pluggable connector
- Connect each of the ground studs on the module carrier to a local, high integrity earth with a cable having a resistance of less than 1 ohm. This should be a clean 'instrument' earth that is electrically bonded to the point of earthing of the local 230V AC power supply to the equipment cabinet that houses the FISCO power supplies. The two studs should be wired with separate cables, each having a cross-sectional area of 4mm<sup>2</sup> or greater.

**Note:** To comply with product certification, all segment connections are required to have their connector plugs in place - as seen in Figure 4.3 - see also Section 6 - Appendix.

### 4.3.1 Field segment terminators

Near-end termination of the intrinsically safe field segments is automatically provided in the FISCO power supplies. Far-end termination must be provided in the field junction box for each segment, for example by selecting Megablock wiring hubs with built-in terminators.

## 4.4 Control System Cable Connections

Redundant control system terminals are provided at the top of the board for connection to ALF111 Fieldbus Interface modules. These terminals, marked HOST 1A and HOST 1B accept standard Yokogawa AKB336 cables. The 9108-CA is supplied with blanking plates fitted over both of these connectors; unscrew and remove a blanking plate to enable a host cable connector to be inserted.

**Note:** To comply with product certification, an **unused host connector** (HOST 1A or HOST 1B) must have its (supplied) blanking plate in place - see also Section 6 - Appendix.

### 4.4.1 Host segment terminators

Terminators for each of the four host segments are provided on the module carrier, not in the

**Figure 4.4**  
Host  
connectors



FISCO power supply. (This ensures that the terminator is not lost, or duplicated, when the power supply modules are switched or removed from the carrier.)

In addition, because of the short length of the AKB336 cables between the ALF111 Interface modules and the 9108-22 assembly, the *host end termination* is incorporated in the same terminator. This method ensures the correct impedance is presented to the host. Therefore, a Fieldbus Terminator (type YCB138) should not be connected at the H1 terminals of each segment on the ALF111 communication modules

## 5 TESTING AND FAULT FINDING

The 9108-22 is provided with switches and LED indicators to enable the user to understand the status of the equipment at any time. The functionality of these diagnostic aids is described in this section.

### 5.1 Testing

After installation, or during maintenance checks, the measured output voltage at the segment terminals should not be less than 12.9V DC\*. This, and many other useful fieldbus parameters, can be measured with the MTL-Relcom FBT-6 portable tester, which also has the advantage of being certified for use in Zone 1 hazardous area.

\* for ambient temperatures of > 20°C

### 5.2 Manual Failover testing

Each Supply Arbitration Module (SAM) has a 'Failover' switch to test the functioning of the failover mechanism from Active to Standby power supply. This is for proof-testing of the power supply as part of a scheduled maintenance program.



**Figure 5.1**  
SAM failover  
switch button

### CAUTION!

Forcing a change of state of the active and standby modules by manually operating the 'Failover' push button is recommended only during plant shutdown, not during the operation of a live process application.

A manual changeover is caused by pressing the Failover switch on the *Active* SAM. Pressing the Failover switch on the *Standby* SAM will have no effect.

**Note:** The default startup configuration always makes the 'A' power supply active. 'A' and 'B' modules are identifiable from silkscreen markings on the circuit board or see Figure 2.2

To confirm the Failover action of a redundant pair - with the 'A' power supply active:

1. Press the Failover switch on the 'A' SAM to force the Standby 'B' power supply to become the Active one.
2. Press the Failover switch on the 'B' SAM to force the 'A' power supply to become the Active one again.

Failover will NOT occur if the Standby power supply, or its associated SAM is in a 'failed' condition; indicated by both the Active and Standby LEDs being extinguished, or by either of them flashing - see Section 5.3.2.

## 5.3 LED Indicators

### 5.3.1 Power A and Power B indicators

LED indicators are provided beside the POWER A and the POWER B connectors; these indicate the presence of applied voltage at the respective connectors - see Figure 4.1.

**Table 5.1**  
**Power input**  
**LED functions**

	OFF	ON
Power (green)	Power fail	Power OK

### 5.3.2 FISCO power supply indicators

Four LED indicators are provided on the front panel of the 9122-IS-CM FISCO Power Supply. The function of these indicators is provided in Table 5.1 below. The normal "healthy" state is indicated by the shaded boxes in the table.

**Table 5.2**  
**Power module**  
**LED functions**

	OFF	ON
Power (green)	Power fail or internal fault	Power OK
Fault (red)	Normal	Fault
Host (yellow)	Comms failure	Comms OK
IS (yellow)	Comms failure	Comms OK

### 5.3.2 Supply Arbitration Module indicators

Two LED indicators are provided on the front panel of the 9129-IS SAM module to indicate its current mode. The function of these indicators is given in Table 5.2 below. "Healthy" states are indicated by the shaded boxes in the table.

**Table 5.3**  
**SAM**  
**LED functions**

Active Mode	Active LED - ON	Standby LED - OFF
Standby Mode	Active LED - OFF	Standby LED - ON
Fault/Alarm Mode	Active LED or Standby LED - OFF or FLASHING*	

\* Note: During startup, either of the LEDs may flash for up to 10 seconds - this is normal operation.

## 6 APPENDIX : ATEX CERTIFICATION INFORMATION

The following information is in accordance with the Essential Health and Safety Requirements (Annex II) of the EU Directive 94/9/EC [the ATEX Directive - safety of apparatus] and is provided for those locations where the ATEX Directive is applicable.

### 6.1 General

- a. This equipment must only be installed, operated and maintained by competent personnel. Such personnel shall have undergone training, which included instruction on the various types of protection and installation practices, the relevant rules and regulations, and on the general principles of area classification. Appropriate refresher training shall be given on a regular basis. [See clause 4.2 of EN 60079-17].
- b. This equipment has been designed to provide protection against all the relevant additional hazards referred to in Annex II of the directive, such as those in clause 1.2.7.
- c. This equipment has been designed to meet the requirements of associated electrical apparatus in accordance with EN 60079-11, EN 60079-0.

### 6.2 Installation

- a. The installation must comply with the appropriate European, national and local regulations, which may include reference to EN 60079-14. In addition, particular industries or end users may have specific requirements relating to the safety of their installations and these requirements should also be met. For the majority of installations the Directive 1999/92/EC [the ATEX Directive - safety of installations] is also applicable.
- b. Unless already protected by design, this equipment must be protected by a suitable enclosure against:
  - i) mechanical and thermal stresses in excess of those noted in the certification documentation and the product specification,
  - ii) aggressive substances, excessive dust, moisture and other contaminants.
- c. To comply with the product's IP20 rating the following points must be noted.
  - i) all power connector plugs, segment connector plugs and the alarm connector plug must be in place.
  - ii) an unused host connector (HOST 1A or HOST 1B) must have its blanking plate in place.

### 6.3 Inspection and maintenance

Inspection and maintenance should be carried out in accordance with European, national and local regulations which may refer to EN 60079-17. In addition specific industries or end users may have specific requirements which should also be met.

### 6.4 Repair

This equipment cannot be repaired by the user. If the 9108-CA circuit board or any one of the modules is suspected of being defective it must be replaced with an equivalent certified product.

### 6.5 Marking

The product is marked in compliance with the Directive and CE marked with the Notified Body Identification Number.

This information applies to products manufactured during or after the year 2009.





**MTL Instruments Pty Limited**

9 /12 Billabong Street  
Stafford  
Queensland 4053  
Australia  
Tel: + 61 1300 308 374 Fax: + 61 1300 308 463  
E-mail: enquiries@mtlaus.com.au

**MTL Canada Safety Instrumentation**

#102, 4249 97 Street  
Edmonton, Alberta  
Canada T6E 5Y7  
Tel: +1 780 485 3132 Fax: +1 780 485 3122  
E-mail: cinfo@mtlnh.com

**MTL Instruments China Co. Ltd.**

Room 1002A, The Gateway  
No 10 Yabao Road, Chaoyang District  
Beijing 100020  
China  
Tel: +86 010 8562 5718/5720/5721 Fax: +86 010 8562 5725  
E-mail: bjsales@mtl-inst.cn

**MTL Instruments sarl**

Les Carrés du Parc  
10 rue des Rosiéristes  
69410 Champagne au Mont d'Or  
France  
Tel: +33 (0)4 78 64 98 32 Fax: +33 (0)4 78 35 79 41  
E-mail: info@mtl-inst.fr

**MTL Instruments GmbH**

An der Gumpgesbrücke 17  
D-41564 Kaarst  
Germany  
Tel: +49 (0)2131 718930 Fax: +49 (0)2131 7189333  
E-mail: info@mtl.de

**MTL India**

No. 36, Nehru Street  
Off Old Mahabalipuram Road  
Sholinganallur  
Chennai - 600 119  
India  
Tel: + 91 (0)44 24501660/24501857 Fax: + 91 (0)44 24501463  
E-mail: sales@mtlindia.com

**MTL Italia srl**

Via Cantù 11  
I - 20092 Cinisello Balsamo MI  
Italy  
Tel: +39 (0)2 61802011 Fax: +39 (0)2 61294560  
E-mail: info@mtl-inst.it

**MTL Instruments KK**

3rd Floor, Gotanda Masujima Building  
1-8-13 Higashi-Gotanda, Shinagawa-Ku  
Tokyo 141-0022  
Japan  
Tel: +81 (0)3 5420 1281 Fax: +81 (0)3 5420 2405  
E-mail: sales@mtlkk.co.jp

**MTL Instruments BV**

PO Box 55, 6680 AB Bommel  
de Houtakker 36, 6681 CW Bommel  
The Netherlands  
Tel: +31 (0)481 450250 Fax: +31 (0)481 450260  
E-mail: info@mtlbenelux.com

**MTL Instruments Pte Limited**

No. 2 Serangoon North Avenue 5  
#06-01 Fu Yu Building  
Singapore 554911  
Tel: +65 6 487 7887 Fax: +65 6 487 7997  
E-mail: sales@mtlsing.com.sg

**MTL Instruments**

Villa No. 4, Sector 2-17, Street 6  
PO Box 53234,  
Abu Dhabi, UAE  
Tel: +971 2 446 6840 Fax: +971 2 446 6841  
E-mail: mtlgulf@mtl-inst.com

**Measurement Technology Limited**

Great Marlings, Butterfield, Luton, Beds  
England LU2 8DL  
Tel: +44 (0)1582 723633 Fax: +44 (0)1582 422283  
E-mail: enquiry@mtl-inst.com

**MTL Incorporated**

3413 N. Sam Houston Parkway W.  
Suite 210  
Houston TX 77286  
USA  
Tel: +1 281 571 8065 Fax: +1 281 571 8069  
E-mail: info@mtl-inst.com

