



F101/102

Fieldbus power supply

- Fieldbus power for FOUNDATION™ fieldbus H1 cards
- Compact design
- Fully isolated
- Low power dissipation
- DIN-rail mounting
- Supports bussing of input power in the DIN rail
- F101 (21.5V min. at 500mA)
- F102 (27.9V min. at 500mA)



The F101 and F102 fieldbus power supplies are designed to provide power for a single FOUNDATION™ fieldbus H1 segment. Galvanic isolation, power conditioning and segment termination are incorporated into each F101 or F102 module. Termination of the fieldbus segments is normally enabled with a switch on the module, but may be switched off for those few applications that do not require a Terminator at the Fieldbus Power Supply.

For extreme reliability, the modules use passive components for power conditioning and a reliable DC/DC converter to provide galvanic isolation and power regulation. The connectors used for power input and the Fieldbus are high quality pluggable types with screw retention. Spring-clamp (-PC) and screw-terminal (-PS) connector versions are supported.

The modules can be powered from a supply between 19.2 – 30.0 DC. The incoming power can be applied via a top-mounted connector, which supports onward looping of power wiring, or by using a proprietary plug-in connector on a DIN-rail bussing system.

LED indicators show the status of the modules. In normal operation, the green Power LED is lit, showing that there is proper input voltage to the module and the red Fault LED is off. If the fieldbus segment is shorted, or in an over-current condition, the Fault LED blinks. An internal module error is indicated by a steady light on the red Fault LED. The status of the internal terminator switch is also indicated by an illuminated 'T' symbol.

F101 and F102 modules provide galvanic isolation between the input power and the fieldbus segments, as required by the IEC61158-2 fieldbus standard and the Fieldbus Foundation™ FF-831 validation test for fieldbus power supplies.

The F101 is specifically intended for use in applications that require live-workable, energy-limited spurs in Zone 2 or Division 2 hazardous areas where the field devices are certified Ex nL or Ex i with $U_i \leq 24V$.

The F102 has a high output voltage and should be specified for applications requiring heavily loaded segments and/or long cable lengths.

FOUNDATION™ fieldbus is a trademark of Fieldbus Foundation™, Austin, Texas.

SPECIFICATION

Location of equipment

Safe Area, Class I Div 2 Groups ABCD T4, or
Class I Zone 2 IIC T4 hazardous area
IEC Zone 2 IIC T4 or Zone 22 hazardous area

INPUT

Input voltage

19.2 – 30.0V DC

Reverse polarity protection

Yes

Current consumption

see Input Current graph

Power dissipation

see Power Dissipation graph

Note: modules are capable of operating at full load without spacing

OUTPUT

Number of Channels

One (1)

Voltage

F101: 21.5 – 24.0V DC

F102: 27.9 – 30.0V DC

Design Current

0 to 500mA per segment

Segment Current Limit

> 550mA

Minimum Load

0mA

Isolation

Fieldbus to input power: Tested at 500V ACrms in accordance with FF-831

ELECTRICAL CONNECTIONS

Fieldbus wiring (host and field)

Screw-secured, 3-way pluggable connectors in screw terminal or spring clamp version, 0.14 to 2.5mm²

Power input

Screw-secured, 4-way pluggable connector in screw terminal or spring clamp version, 0.14 to 2.5mm² (see diagram)

DIN-rail power bussing option

Proprietary connection system - see Ordering Information

Fieldbus terminator

100Ω, switchable

MECHANICAL

Mounting method

Integrated fixings for vertical 'Top hat' DIN-rail, 35mm x 7.5mm to EN50022

Housing material

Polycarbonate

Tagging strip

To accept paper legend

ENVIRONMENTAL

Ambient temperature

Operating: -40°C to +65°C* (at maximum rated output)

-40°C to +70°C* (at 400mA output)

Storage: -40°C to +85°C

* fitted on horizontal DIN-rail mounted on a vertical plane

Relative humidity

<95%, non-condensing

Ingress protection

IP20 to BS EN60529 (Additional protection by means of enclosure)

F101/102 - BLOCK DIAGRAM

(showing interconnection scheme)

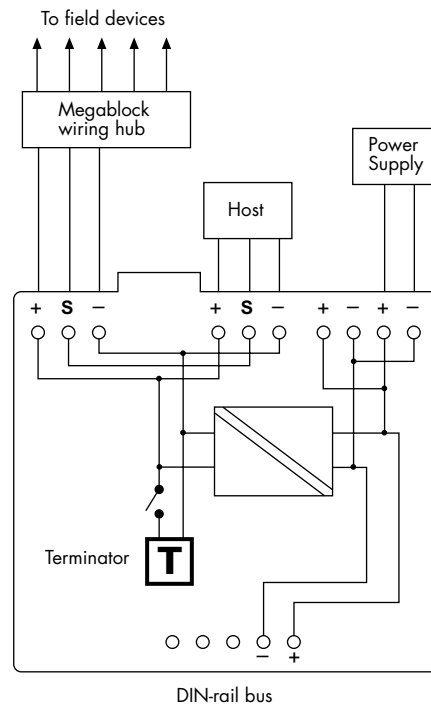

The above diagram shows a basic illustration of how the F101 or F102 is wired. For detailed wiring information, see the installation instructions.

PHYSICAL NETWORKS

IEC61158-2
ISA-S50.02 Part 2-1992
FOUNDATION™ fieldbus H1
Profibus PA

LED INDICATORS

	OFF	ON	Flashing
Power (green)	Power fail or internal fault	Power OK	—
Fault (red)	Normal	Internal error, replace module	Output current limit exceeded
Terminator (white 'T')	Terminator disabled	Terminator enabled	—

The given data is only intended as a product description and should not be regarded as a legal warranty of properties or guarantee. In the interest of further technical developments, we reserve the right to make design changes.



EUROPE (EMEA): +44 (0)1582 723633
enquiry@mtl-inst.com

THE AMERICAS: +1 800 835 7075
csinfo@mtl-inst.com

ASIA-PACIFIC: +65 6645 9888
sales@mtlsing.com.sg

EPS F101/2 Rev4 110613

F101 PARAMETERS (typical)

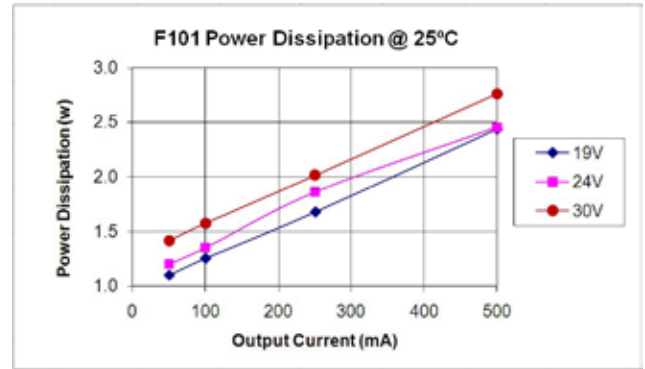
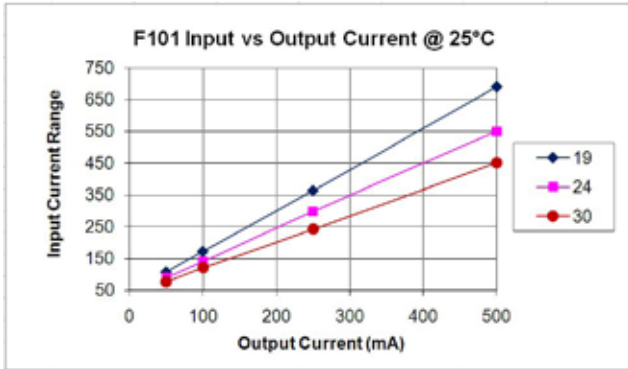

F102 PARAMETERS (typical)

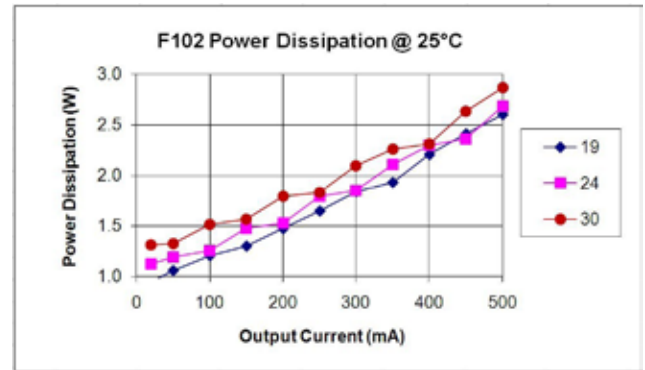
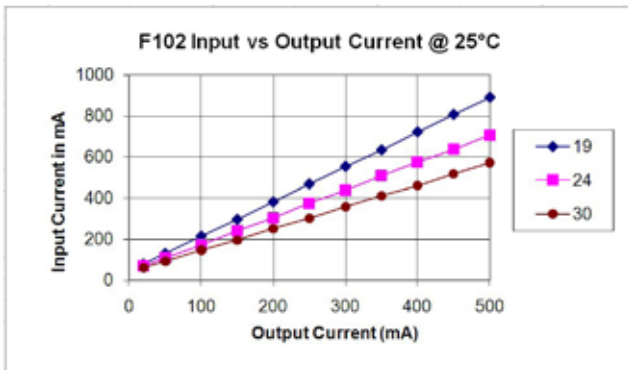

F101/102 DIMENSIONS (mm) (shown with screw-clamp connectors)

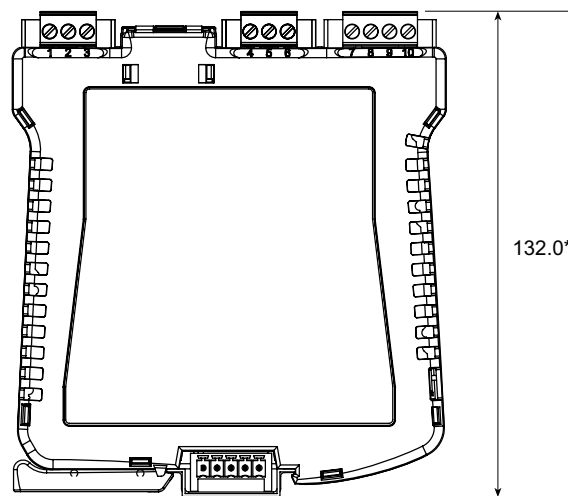
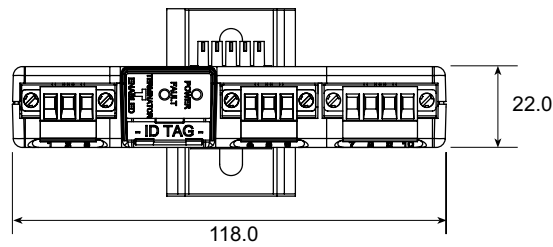

* + 5mm with spring clamp connectors

The given data is only intended as a product description and should not be regarded as a legal warranty of properties or guarantee. In the interest of further technical developments, we reserve the right to make design changes.



EUROPE (EMEA): +44 (0)1582 723633
enquiry@mtl-inst.com

THE AMERICAS: +1 800 835 7075
csinfo@mtl-inst.com

ASIA-PACIFIC: +65 6645 9888
sales@mtlsing.com.sg

EPS F101/2 Rev4 110613

ORDERING INFORMATION

PART No.	Description
F101-PS	Fieldbus Power Supply (21.5V min., 500mA) pluggable screw-terminal connectors
F101-PC	Fieldbus Power Supply (21.5V min., 500mA) pluggable spring-clamp connectors
F102-PS	Fieldbus Power Supply (27.9V min., 500mA) pluggable screw-terminal connectors
F102-PC	Fieldbus Power Supply (27.9V min., 500mA) pluggable spring-clamp connectors

PART No.	Description
PBUS01	Power Bus DIN-rail connectors, pack of 5
PBUS02	Power Bus DIN-rail input plug and socket set
PBUS03	DIN-rail mounted strain relief clamps, pack of 2

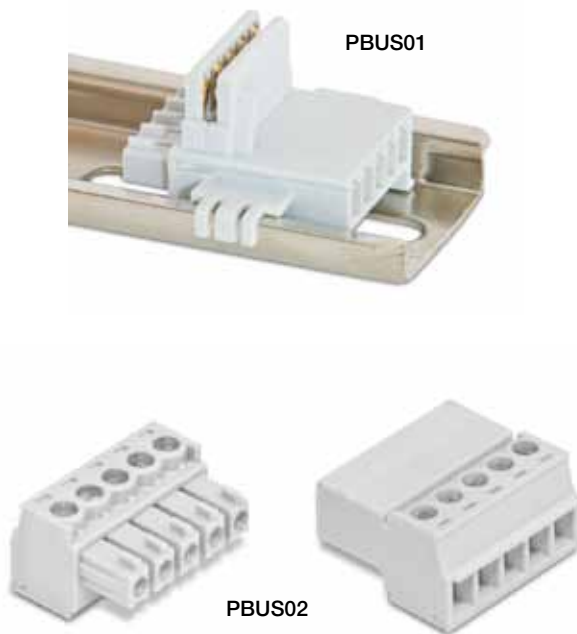

APPROVALS - for the latest certification information visit www.mtl-inst.com/support/certificates

Region (Authority)	Standard	Certificate	Approved for	Ratings
EU (Relcom)	EN61326		Class A Industrial Locations	CE
(Fieldbus Foundation™)	FF-831	PS072900 (F101) PS072901 (F102)	-	Power Supply Type 132
US (FM)	3600: 1998 3611: 2004 3810: 2005	3035979	Class I, Div 2, ABCD, T4 Class I, Zone 2, IIC, T4	NI/I/2/ABCD/T4 Ta=65°C I/2/IIC/T4 Ta=65°C
Canada (FM)	CAN/CSA - E60079-15 C22.2 No. 213 C22.2 No. 1010.1	3035979C	Class I, Div 2, ABCD, T4 Class I, Zone 2, IIC, T4	NI/I/2/ABCD/T4 Ta=65°C Ex nA nL IIC T4 Ta=65°C
ATEX (Relcom)	EN 60079-0 EN 60079-15	RELC09ATEX1008X	Zone 2 IIC T4	Ex nA IIC T4 Ⓢ II 3 GD

The given data is only intended as a product description and should not be regarded as a legal warranty of properties or guarantee. In the interest of further technical developments, we reserve the right to make design changes.



EUROPE (EMEA): +44 (0)1582 723633
enquiry@mtl-inst.com

THE AMERICAS: +1 800 835 7075
csinfo@mtl-inst.com

ASIA-PACIFIC: +65 6645 9888
sales@mtlsing.com.sg

EPS F101/2 Rev4 110613