

9372-FB-Px-xx

5-spur redundant fieldbus barrier



DECLARATION OF CONFORMITY

A printed version of the Declaration of Conformity has been provided separately within the original shipment of goods. However, you can find a copy of the latest version at <http://www.mtl-inst.com/certificates>

CONTENTS

	DECLARATION OF CONFORMITY	II
	GENERAL SAFETY INFORMATION	2
1	OVERVIEW	3
2	DESCRIPTION	4
2.1	General	4
2.2	Configuration options	4
2.3	Trunk Terminal Assembly	5
3	MECHANICAL INSTALLATION	5
3.1	Mounting overview	5
3.2	Preparation	7
3.3	Mounting	7
4	INITIAL ELECTRICAL INSTALLATION	8
4.1	Overview	8
4.2	Grounding	8
4.3	Trunk connections	11
4.4	Trunk Terminator module 9378-FT	13
4.5	Trunk Surge module 9376-SP	13
4.6	Spur connections	13
4.7	Blanking Plugs	14
4.8	Final Checks	15
5	MAINTENANCE	15
5.1	General	15
5.2	Fieldbus Barrier maintenance procedures	15
5.3	Terminator and Trunk Surge Protection modules	17
5.4	Spur connections	18
5.5	Trunk connections	19
5.6	Regular Maintenance checks	19
6	TROUBLESHOOTING	20
7	ALARM MODULE - OPERATION & CONFIGURATION	22
7.1	Introduction	22
7.2	Device details	22
7.3	Alarm module fitting or replacement	24
8	ATEX INFORMATION	25
8.1	General	25
8.2	Installation	25
8.3	Inspection and maintenance	25
8.4	Repair	26
8.5	Marking	26
9	APPENDIX 1 - ENCLOSURE WIRING DIAGRAM	27

GENERAL SAFETY INFORMATION

Safety instructions for installation and operating personnel

The operating instructions provided here contain **essential safety instructions** for installation personnel and those engaged in the operation, maintenance and servicing of the equipment.

	WARNING!
	Failure to comply with these instructions can endanger the lives or health of personnel and risk damage to the plant and the environment.

	WARNING!
	The responsibility for planning, installation, commissioning, operation and maintenance, particularly with respect to applications in explosion-hazard areas, lies with the plant operator.

Before commencing installation or commissioning:

- Read and understand the contents of this manual
- Ensure installation and operating personnel have received adequate training for this task
- Ensure that any operating instructions are fully understood by the personnel responsible.
- Observe national and local installation and mounting regulations (e.g. IEC 60079-14).

	WARNING!
	These assemblies may not be used in explosion-hazard area applications if they have been used previously in general electrical installations.

During operation:

- Make the relevant instructions available at all times to the operating personnel.
- Observe safety instructions.
- Observe national safety and accident prevention regulations.
- Operate the equipment within its published specification.
- Servicing, maintenance work or repairs not described in this manual must not be performed without prior agreement with the manufacturer.
- Any damage to this equipment may render its explosion protection null and void.
- No changes to any of the components that might impair their explosion protection are permitted.

If any information provided here is not clear:

- Contact **Eaton's MTL product line** or one of its representatives.

Note: Improper installation and operation of the enclosure can result in the invalidation of the guarantee.

CAUTION
Earlier models of the Fieldbus Barrier Module (9377-FB) that do not have the “-R” at the end of the model number cannot be used in the products described here. A mechanical interlock prevents their being fitted to the carriers. Do not attempt to fit these models as damage to the carrier may result.

937X-FB-Px-yy Redundant Fieldbus Barrier 5-spur enclosures

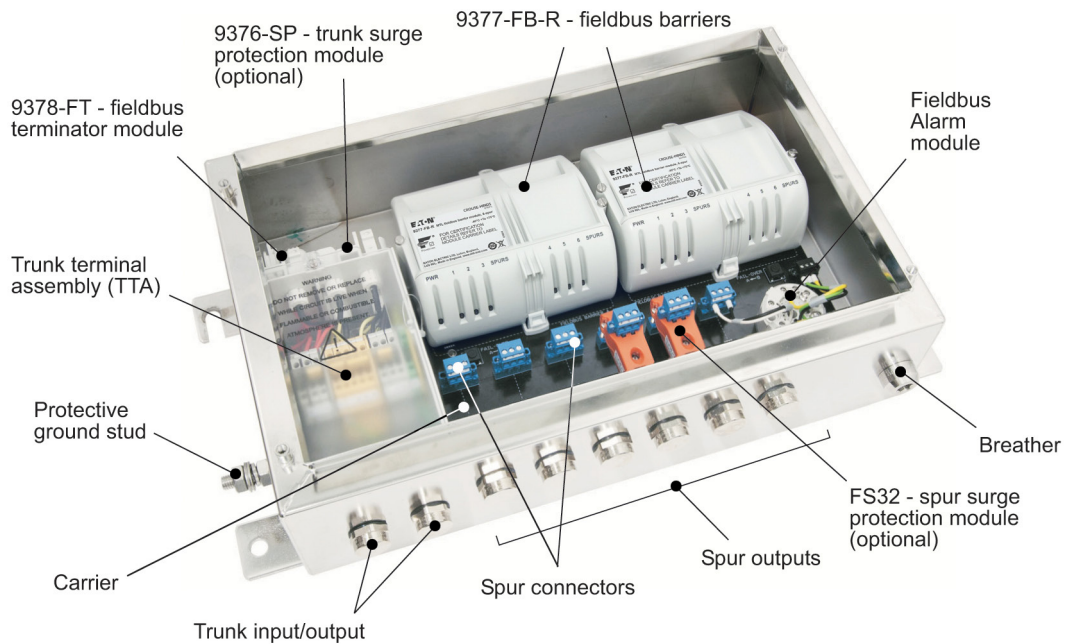

Figure 1.1 - Example of model 9372-FB-XX-SS

1 OVERVIEW

This manual explains the installation and maintenance procedures for the 9372-FB-xx-yy Redundant Fieldbus Barrier enclosures and must be read in association with the product datasheets that contain the electrical data.

The 9372-FB-xx-yy Redundant Fieldbus Barriers are field-mounted wiring hubs that create five (or six*) intrinsically safe spur connections from a high-energy trunk, for connection to suitably certified FOUNDATION™ fieldbus H1 instruments. They may be installed in Zone 1 (gas) or Zone 21 (dust) hazardous areas, with the trunk wiring implemented using suitably protected cable and increased safety (Ex e) connection facilities.

Each enclosure system uses a pair of Fieldbus Barrier modules in a “redundant spur” configuration to achieve significantly higher system availability than equivalent ‘simplex’ units. The 9372-FB-xx-yy may therefore be selected for critical process applications where failure of the Fieldbus Barrier would otherwise result in unacceptable downtime or lost production. It is also ideal for use in Fieldbus Safety Instrumented Function (SIF) networks in which nuisance trips cannot be tolerated. Failure annunciation to the host control system is provided by means of an integrated FOUNDATION™ fieldbus device with Digital Input Function Block capability.

The enclosure options are: electrochemically polished 316 stainless steel or glass-reinforced plastic (GRP) and either may be installed in a Zone 1 or Zone 2 hazardous area.

The following enclosure types are available by ordering the appropriate model number.

9372-FB-Px-yy	5-spur Redundant Fieldbus Barrier enclosure
9375-FB-Px-yy	6-spur Redundant-ready Fieldbus Barrier enclosure
Where Px =	PS (pluggable screw terminal connectors) or PC (pluggable spring clamp connectors)
and yy =	SS (316L stainless steel enclosure) or PP (GRP enclosure- black)

* See section 2.2

2 DESCRIPTION

2.1 General

The standard models comprise a stainless steel or GRP, increased safety, Ex e enclosure, containing a trunk-wiring terminal assembly (TTA), two carrier-mounted fieldbus barriers and a fieldbus alarm module.

Each barrier module can convert a single, non-intrinsically safe fieldbus trunk into six, galvanically isolated, intrinsically safe (IS) spur connections for connection to FOUNDATION™ fieldbus H1 fieldbus instruments. However, *only six spurs are available at any one time* because they are configured as “redundant pairs.” On power-up the spurs in one barrier are configured to be in “active” mode, while the spurs in the other barrier remain in “standby.” In the event of a spur circuit failure in the “active” barrier module, an automatic switchover ensures that the external spur field circuit *continues to be supported* by the corresponding spur in the “standby” module.

Figure 2.1 illustrates an example where Module A- on the left- is the active barrier and Module B the standby. Spurs 1,2, 4, 5 and 6 of Module A are shown as active ('A') but spur 3 has failed (and effectively gone into standby) so module B has automatically taken control of spur 3 ('A') to maintain full service to the affected field circuit.

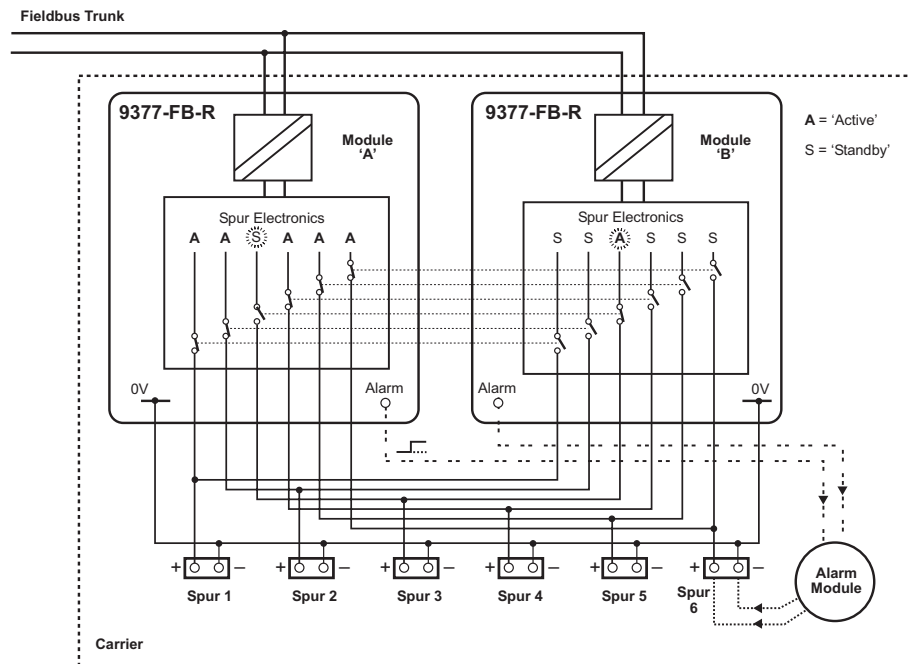

Figure 2.1 - Redundant spurs block diagram + optional alarm module

The spurs are galvanically isolated from the trunk allowing the user to choose the type of grounding scheme most suitable to their system.

Spur short-circuit protection is provided by the barrier and surge protection can also be added on individual outgoing spurs by the use of individual Spur Surge protection modules (part no. FS32).

2.2 Configuration options

There are six spur outputs from each barrier and, as described above, these can operate in a redundant fashion, supporting each other to maintain continuous availability for field spur devices. However, if a spur “fails-over” to the other barrier, the situation might go undetected without frequent inspection of the status of the barrier LEDs. For this reason, a “failure-reporting” configuration is provided, where Spur 6 is assigned to an internally located Alarm Module (model 9379-ALM)- see Figure 2.1.

Consequently, if a spur 'fail-over' occurs, an alarm is signalled quickly to the host, via the fieldbus connection, to facilitate any necessary remedial action. The five remaining spurs are available to the user for connection to field devices.

Note: A *redundant-capable* version of the 9372-FB-Px-yy can also be supplied, part-populated with a single 6-spur module (order as model number 9375-FB-Px-yy). This permits a future upgrading from the simplex mode to a redundant mode simply by plugging in an additional Fieldbus Barrier module- and the optional alarm module, if required.

2.3 Trunk Terminal Assembly

The incoming trunk wiring is terminated inside a separate compartment, called the Trunk Terminal Assembly (TTA), that contains increased safety (Ex e) trunk wiring terminals. This assembly has a protective cover to deter interference, and carries a warning to the user about working on trunk wiring without first isolating the power. A fieldbus Terminator module (part no. 9378-FT) is supplied pre-fitted on the TTA. This is to remain installed if the enclosure is at the end of the segment. If the incoming fieldbus trunk will be onward linked to a further node on the segment the terminator can be removed. See Section 4.4 on page 13 for additional information.

An optional Trunk Surge module (part no. 9376-SP) can be plugged into the TTA to protect the fieldbus barrier against damaging voltage and current surges on the incoming trunk wiring.

Either enclosure may be installed in a Zone 1 or Zone 2 hazardous area; in which case, the trunk wiring must be implemented using suitably protected cable. The enclosures provide excellent chemical and moisture resistance and are suitable for use in a wide range of corrosive environments.

The 9372-FB-Px-yy and 9375-FB-Px-yy Fieldbus Barrier enclosures are bus-powered and require no additional power supply in the field. When used with a fieldbus host control system, power for the trunk MUST be provided only by a supply conforming to IEC 61158-2, e.g. MTL F800 or 918x range of redundant power supplies. The enclosures are supplied pre-drilled for all trunk and spur cable entries and fitted with Ex e certified blanking plugs and a breather.

3 MECHANICAL INSTALLATION

See Figures 3.1 and 3.2 for the dimensions, fixing locations and cable gland positions for both enclosure models.

3.1 Mounting overview

Before mounting an enclosure, consider the following points.

- a) The permitted ambient temperature range external to the enclosure (-40°C to +70°C) must not be exceeded. Avoid radiant heat by locating the enclosure away from direct sunlight or local sources of heat.
- b) The enclosure has an ingress protection rating of IP65 or IP66 (to EN60529) depending on the manufacturing date. The mounting location should be chosen to comply with the rating of the enclosure.
- c) The enclosure is designed for mounting on a vertical surface, with the cable entry at the lowest point, as shown in the upper part of Figure 3.1 or Figure 3.2.
- d) The nominal weight of the individual enclosures, including two barrier modules, but excluding any surge protection modules (trunk or spur) is:

Model type	Nominal weight
Stainless steel enclosure	8.0 kg
GRP enclosure	7.8 kg

- e) Adequate security should be provided against unauthorised interference.

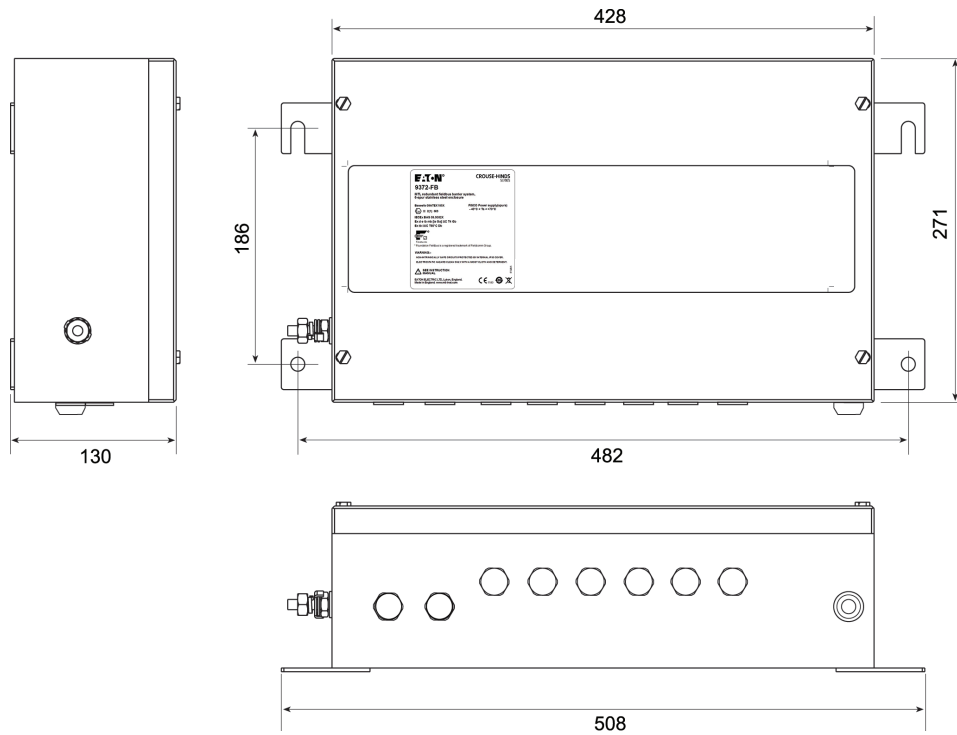
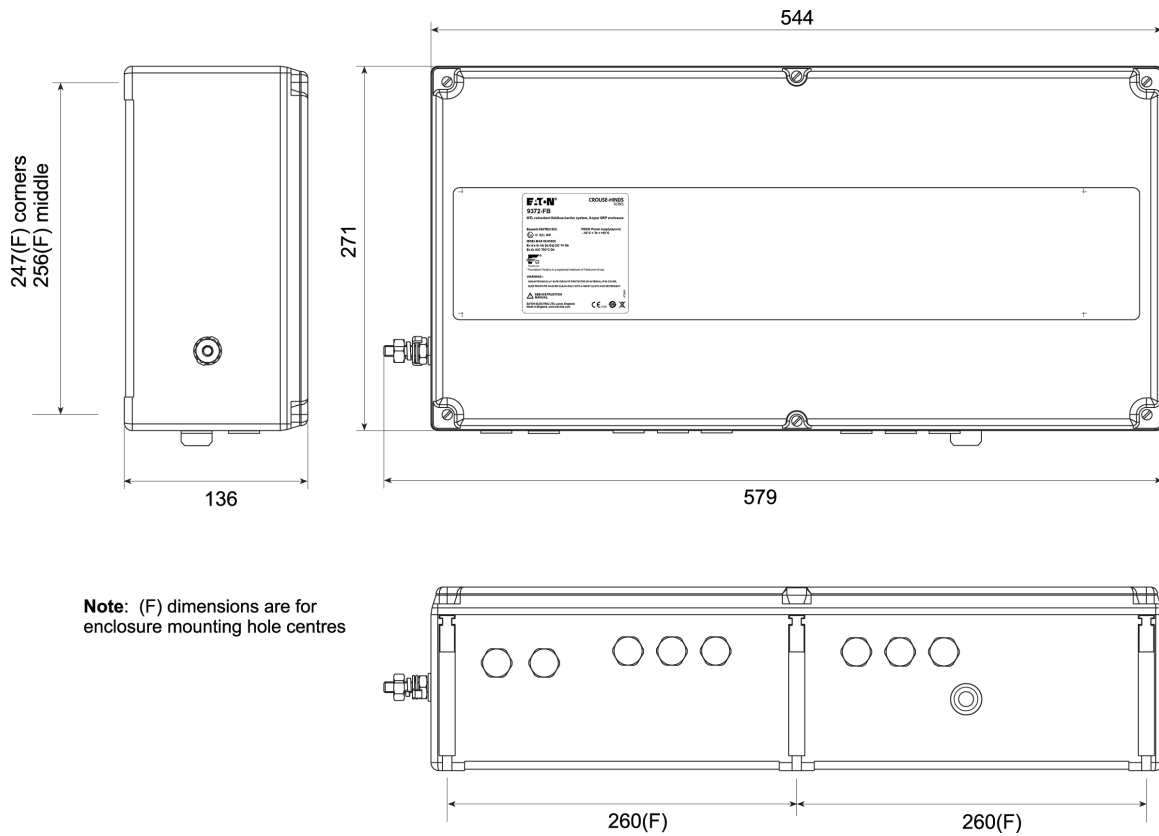

Figure 3.1 - External dimensions and mounting hole positions for the stainless steel enclosure



Note: (F) dimensions are for enclosure mounting hole centres

Figure 3.2 - External dimensions and mounting hole positions for the GRP enclosure

- a) All the necessary gland holes have been prepared in the enclosure. One has a breather fitted and the others are fitted with appropriate blanking plugs. Where the blanking plugs are replaced by cable gland, the fitted glands must be Ex e certified and have an ingress protection (IP) rating that maintains the overall rating of the enclosure.
- b) All cable gland holes must be fitted with either a suitable cable gland or blanking plug.

CAUTION
It is not permitted to create additional holes in the enclosure as this would violate the certification.

3.2 Preparation

- a) Remove any temporary protection or packing materials.
- b) The enclosure can be mounted on any suitable structure using the enclosure’s integral mounting brackets.
- c) The fixing bolts must be suitable for the mounting surface and the environmental conditions.
- d) Prepare holes in the mounting surface, on the centres shown in Figure 3.1 or 3.2, to accept suitable screws/bolts for mounting.
- e) It is advisable before mounting, to do any necessary replacement of the cable entry blanking plugs with a suitable gland. For further details see Section 3.1 f) & g).

3.3 Mounting

	WARNING!
	<p>To minimise the risk of ignition by electrical apparatus in hazardous areas, efficient installation, inspection and maintenance of apparatus and systems is essential, and the work should be carried out by suitably trained personnel in accordance with the prevailing code of practice.</p> <p>The certification documents specify “Conditions for safe use” that must be adhered to and the copy certificate supplied should be studied and understood. Additionally it is recommend that a working knowledge of IEC EN 60079 -14 be attained, as this standard provides guidance in respect to the installation of electrical equipment in hazardous areas.</p>

3.3.1 The SS enclosure

It is suggested that the upper two fixing bolts have washers fitted before screwing them into prepared holes to a depth that will allow the enclosure to be safely hung on them. The enclosure can then be supported on these top bolts while the lower fixings are put in place. Finally, all fixings can be tightened to the torque level recommended by their manufacturer.

3.3.2 The GRP enclosure

It is recommended that a washer, not exceeding the 12mm diameter specified in Figures 3.1 and 3.2, is placed under the head of each of the bolts used to fix the enclosure to its mounting surface.

NOTE!
It is important to recognise that the hole centres for the <i>middle</i> fixings on the GRP enclosure are NOT aligned with the holes for the <i>end</i> fixings. Study Figure 3.2 for full details.

It is suggested that the lower fixings should be put in place first, so that the enclosure can be supported by them while the upper fixings are put in place.

After mounting the enclosure

Check that:

- it has not suffered any damage,
- the IP rating is not affected; for example, by distortion of the enclosure,
- the mounting bolts/nuts are all tightened as recommended above.

4 INITIAL ELECTRICAL INSTALLATION

	WARNING!
	Before starting any electrical installation work, ensure that the incoming trunk connection is isolated from any source of power.

CAUTION
The temperature inside the enclosure could rise to 75°C. Ensure that all cables and cable glands fitted are rated to withstand these temperatures.

4.1 Overview

Captive screws are used to secure the lid. Loosen these screws to obtain entry.

CAUTION
The lid of the stainless steel enclosure is connected to the enclosure body with a protective grounding cable. DO NOT leave the lid hanging by this link cable while work is carried out!

- The enclosure receives power from the incoming trunk cable and requires no further source of power.
- The equipment shall only be powered from supplies conforming to IEC 61158.
- Type 'A' fieldbus cable is recommended for fieldbus trunk connections.
- The terminal blocks for the trunk fieldbus cables have either screw terminal connectors or cage clamp connectors according to the enclosure model specified, but both are suitable for cables from 0.5mm²/AWG 20 up to 2.5mm²/AWG 14.

On completion of installation, check all blanking plugs and cable glands are tightened to ensure IP rating of the enclosure is maintained.

Details of the internal wiring for the two enclosure types is provided in Appendix 1.

4.2 Grounding

Two distinct ground concepts should be recognised before wiring of the enclosure begins:

- a) Protective local ground- mandatory
- b) Cable shield ground

These two concepts and their implementation are explained below.

4.2.1 Protective local ground

This ground connection is required to ensure that any exposed metalwork in, or on, the enclosure does not present a hazard to personnel; it also provides a low impedance earth grounding circuit for any surge protection items used in the enclosure. An external M10 earth-grounding stud is provided on the side wall of the enclosure to enable a connection to be made to the local ground.

Use a ring terminal to make a good quality, plant safety-earth connection (4mm² cross-sectional area or better) to this bolt and tighten it to a recommended torque of 5Nm.

Note: It is important to prevent this connection from loosening and also to protect it from corrosion against the stainless steel grounding stud.

4.2.2 Cable shield ground

The enclosures can be configured by the user to either of two grounding methods. The user should adopt the one that conforms to their system's normal grounding method.

NOTE:

Whichever method is used, it is important to connect the screen/shield to ground at **one end** of the cable only.

The cable shield is normally electrically isolated from the protective earth ground, although the two may be deliberately interconnected in some grounding arrangements. The cable shield wiring of the trunk and spur cables should be connected to the local terminals marked with an 'S'.

The following options are available to the user.

	WARNING!
	<p>The following may involve changes to wiring in the Trunk Terminal Assembly. No part of the Trunk Terminal Assembly may be worked while the enclosure is powered, unless the environment is known to be non-hazardous.</p>

4.2.2.1 Single point of grounding at host; trunk & spur shields interconnected

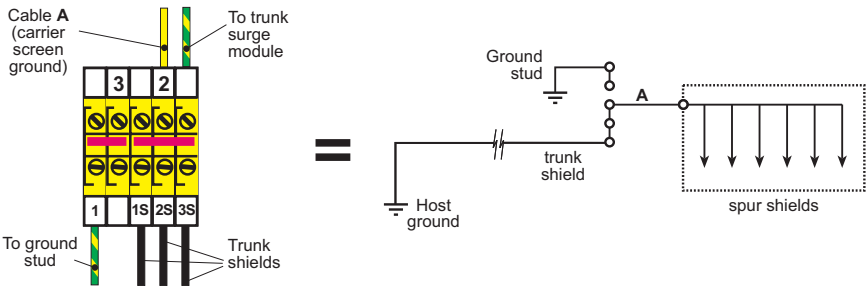

Figure 4.1 - Option 1

In many installations, the preferred method of grounding is to ground the fieldbus cable shields at one point only, normally at the fieldbus power supply. In this case, the trunk and spur cable shields are connected to each other at the Fieldbus Barrier and are not connected to ground in the field. For this arrangement, connect the carrier shield ground wire (marked A) into Terminal 2.

Note: this is the default grounding method for factory-supplied 937x-FB enclosures.

IMPORTANT NOTE
<p>937x-FB enclosures are factory-supplied with Option 1 grounding. If power is applied locally, for example during commissioning, when the trunk cable shield is NOT providing a ground connection, the spur cable shields must be grounded according to Option 2.</p> <p>When the trunk cable shield ground has been fully instated (or restored), the grounding method should be returned to Option 1.</p>

4.2.2.2 Trunk shield grounded at host; spur cable shields grounded at barrier

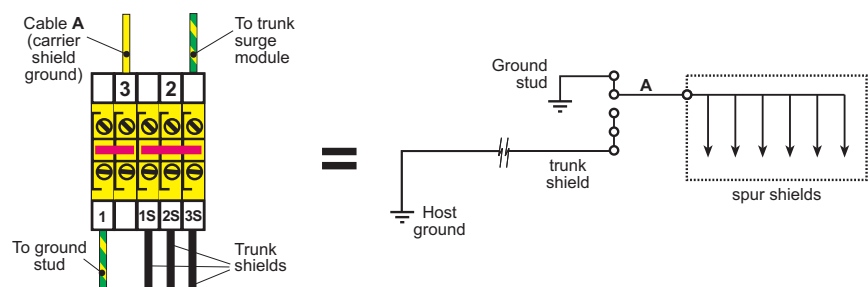

Figure 4.2 - Option 2

With this arrangement, the fieldbus trunk shield is separated from the spur cable shields. It should be adopted if plant or local regulations require that the spur cable shields be grounded at the Fieldbus Barrier. For this arrangement, connect the carrier shield ground wire (marked A) into Terminal 3.

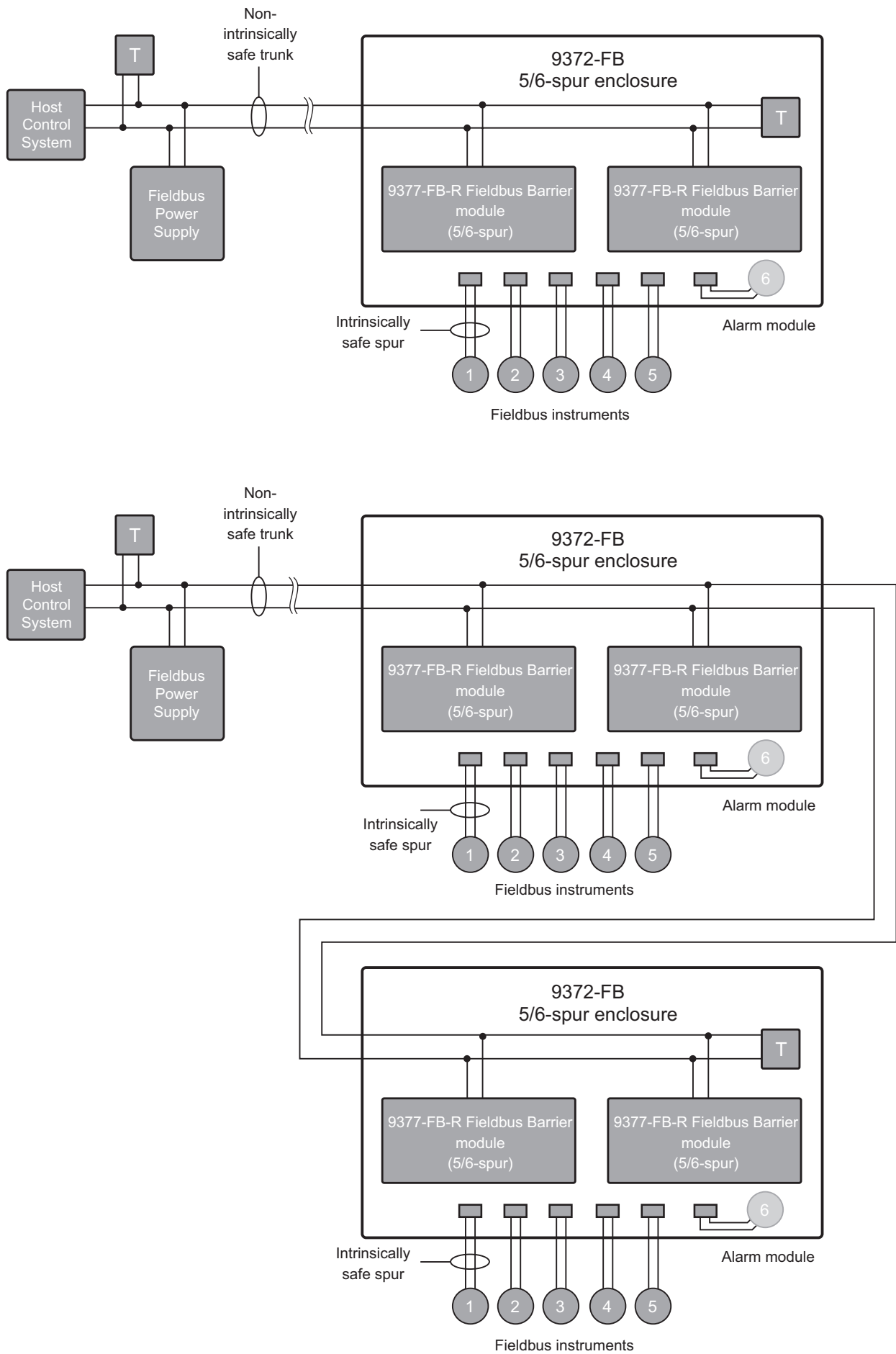

Figure 4.3 - Trunk Connection Options

Note: After configuring the required grounding option, tighten all screw terminals to a recommended torque of 0.6 Nm.

4.2.3 Permitted enclosure combinations

The maximum number of redundant intrinsically safe spurs that can be supported on a trunk segment is 12. The permitted enclosure combinations are shown in Figure 4.3.

Note that a fieldbus trunk terminator (9378-FT) must be fitted (see Section 4.4) to the last/furthest enclosure on the segment. See also Figure 4.6.

4.3 Trunk connections

Each enclosure is provided with two access holes for trunk glands; one for the incoming trunk and another for onward linking to an additional enclosure, if necessary.

	WARNING!
	No part of the Trunk Terminal Assembly may be worked while the enclosure is powered, unless the environment is known to be non-hazardous.

4.3.1 Trunk Terminal Assembly

Inside the enclosure, the trunk cables are terminated in a Trunk Terminal Assembly (TTA). This is a sub-enclosure with a protective lid, secured with a single screw. This assembly, together with its warning label, is intended to deter a user from working on the trunk connections without isolating trunk power. See Figure 4.4.

Trunk cables enter via glands, through the enclosure wall shown at the bottom of the diagram, and the grounding stud is accessible on the lower left side. The trunk terminal connectors are in the middle of the assembly to receive the trunk wiring.

Terminals are provided to allow a variety of wiring arrangements, according to the particular requirements of the installation:

- "Trunk In" cable only
- "Trunk In" and "Trunk Out" cables
- Active and spare "Trunk In" cables
- Active and spare "Trunk In" cables with overall cable shield
- Active and spare "Trunk In" cables and "Trunk Out" cable

CAUTION
The '+' and '-' wires of a 'spare' trunk in cable must be connected only to terminals marked 'NC'. This ensures that the spare cable is not electrically connected in parallel with the 'active' trunk in or trunk out cables. The cable shield of the spare cable should be connected to an 'S' terminal.
All 'spare' trunk-in connections ('+', '-' and shield) must be firmly grounded at the host.

4.3.2 Trunk cable wiring

Cable ferrules should be fitted to all multi-stranded cables being terminated in the TTA.

Connect the trunk cable(s) in the following way.

- a) Loosen the captive screw of the transparent protective cover on the TTA. Slide out the cover and move it to one side to obtain access.
- b) Prepare the trunk cable(s) in accordance with the gland manufacturer's instructions and feed the cable(s) through the gland(s).
- c) Connect the prepared ends of the fieldbus trunk cable(s) into the appropriate '+', '-', and 'S' terminals, shown in Figure 4.5, and tighten the screw terminals to a recommended torque of 0.6 Nm.

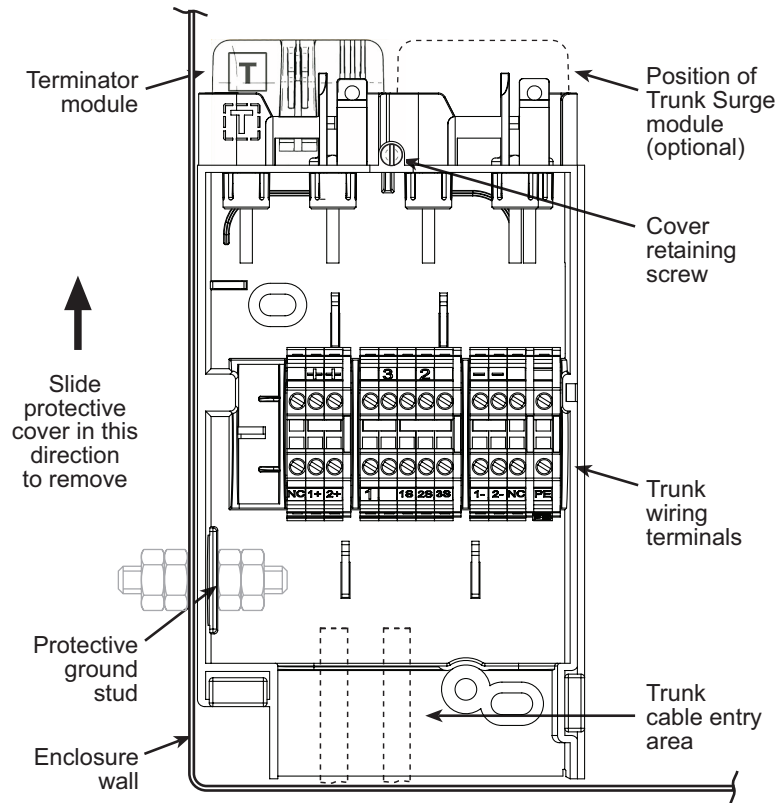

Figure 4.4 - Trunk Termination Assembly (TTA)

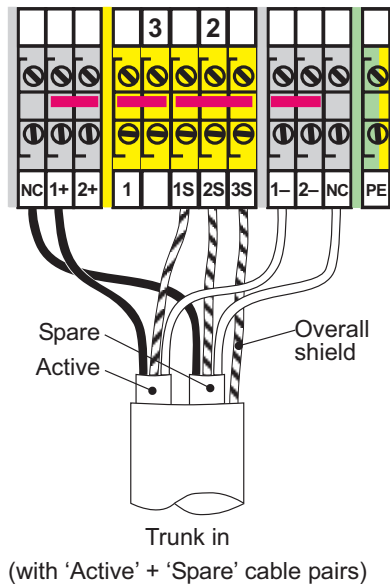

Figure 4.5 - 'Trunk In' with Active & Spare cable pairs

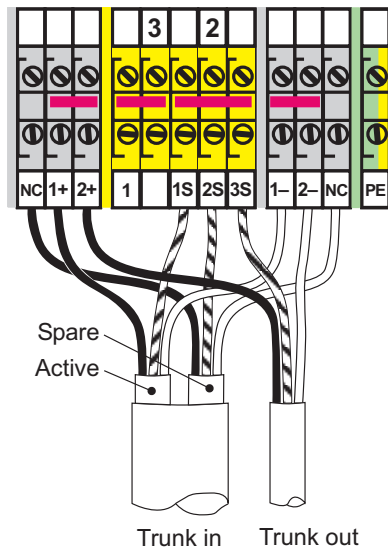

Figure 4.6 - Active & Spare 'Trunk In' cables plus 'Trunk Out' cable

Note: Figure 4.5 shows the screw-terminal ‘-PS’ enclosure option, but the ‘-PC’ cage-clamp terminal arrangement is similar.

Check Section 4.2.2 on page 8 to confirm that the chosen fieldbus-ground option is correctly wired, and adjust if necessary.

- a) Tighten the gland securing nut(s), ensuring that any cables are not strained.
- b) Replace the transparent protective cover over the terminal block and secure it with the retaining screw to a recommended torque of 0.6 Nm.

4.4 Trunk Terminator module 9378-FT

If the enclosure provides the last (or only) spur connections on the segment, the trunk must be terminated correctly to ensure that the optimum signal quality is maintained. The Trunk Termination Assembly (TTA) has provision for an 9378-FT Terminator module to be fitted when required.

NOTE
A terminator should be used only at the end points of the trunk wiring. Connecting a terminator at any other point on the trunk will degrade the signal.

The 9378-FT is a two-pin module that plugs into the upper end face of the Trunk Terminator Assembly. See Section 5.3 on page 17 for fitting and removal details.

4.5 Trunk Surge module 9376-SP

The 9376-SP Trunk Surge module can be fitted to the TTA to prevent damage to the equipment from voltage and current surges that could occur on the trunk wiring.

The 9376-SP is a four pin module that plugs into the upper end face of the Trunk Terminator Assembly. See Section 5.3 on page 17 for fitting and removal details.

4.6 Spur connections

Refer to Figure 4.7 for additional details.

The spur cables can be connected directly onto the fieldbus barrier carrier or through a Spur Surge module (FS32). If Spur Surge modules are not used, Section 4.6.2 on page 14 can be ignored.

4.6.1 Connecting the spur cables

Prepare the spur cables in accordance with the gland manufacturer’s instructions and secure the cables in the glands.

IMPORTANT

- When fitting the cable in the gland allow 20 – 30mm of available cable length outside the enclosure to allow for cable adjustment if a Spur Surge module is taken out of circuit inside the enclosure. See Section 5.4.1 on page 19 for further details
- Cable ferrules must be fitted to any stranded cable or screen wiring that is being used.

Connect the prepared ends of the fieldbus spur cables into the ‘+’, ‘S’ and ‘-’ terminals on the carrier (or surge module, if fitted), making sure that the same polarity is observed for all spurs.

4.6.2 Fitting FS32 Spur Surge modules

Spur Surge modules are pluggable units that integrate easily with the standard pluggable connector and which direct excessive spur surge currents to the protective local ground.



Figure 4.7 - FS32 Spur Surge module on carrier

To fit an FS32:

1. Unscrew the two captive screws securing the standard pluggable connector (supplied on the carrier) and remove it from its socket.
2. Insert the FS32 module into the now vacant socket on the carrier, tighten the two side securing screws to a recommended torque of 0.4 Nm.
3. Ensure also that the central “protective ground” screw is engaged and tightened to a recommended torque of 0.4 Nm to provide a low impedance path for surge currents.
4. Fit the connector (removed at Step 1 above) into the socket on the FS32 and tighten its two securing screws also to a recommended torque of 0.4 Nm.

Removal of a Spur Surge module is the reverse of the fitting process. See also Section 5.4.1 on page 18 for information on cable ‘adjustment’ if one of these modules is taken out of use.

4.7 Blanking Plugs

Blanking plugs of factory-supplied Fieldbus Barriers are lightly tightened for ease of removal. Any blanking plugs that are not removed from the fieldbus barrier must be tightened to the required torque to meet the IP rating.

Two types of blanking plug are supplied with the Fieldbus Barrier as shown in figures 4.8 and 4.9 below and should be tightened to a torque rating as shown in the table below.

Type A	4.8Nm
Type B	12Nm



Figure 4.8 - Type A Blanking plug



Figure 4.9 - Type B Blanking plug

4.8 Final Checks

Before replacing the lids on the enclosure, check:

- that all cable glands and any blanking plugs are tightened securely.
- that all cable glands are tightened to provide the required IP seal in accordance with gland installation instructions.
- that the protective trunk wiring cover is in place on the Trunk Terminal Assembly.
- that no tools (e.g. screwdrivers) or loose items have been left in the enclosure.
- that there is no damage to any cover seal, otherwise it must be replaced with one that has the same manufacturer's part number.
- that if, and only if, the enclosure *is the last one* on the fieldbus segment, that a 9378-FT Terminator module is fitted into the socket on the TTA.
- that the required grounding link is securely connected between the enclosure lid and the enclosure body.

Fit the enclosure lid and tighten all of its securing screws to a recommended torque of 2.5 Nm.

5 MAINTENANCE

When the enclosure is installed in a hazardous area it is important for personnel to understand what activities are permissible when fieldbus power is present and what are not.

	WARNING!
	Read and understand what work is permitted inside the enclosure. Failure to comply with these instructions can endanger the lives or health of personnel and risk damage to the plant and the environment.

5.1 General

The following items in the enclosure may be removed or disconnected while the trunk is still powered.

- 9377-FB-R Fieldbus Barrier module(s)*
- 9378-FT Terminator module
- 9376-SP Trunk Surge module
- 9379-ALM Alarm module
- FS32 Spur Surge modules and any spur wiring

All other wiring in the enclosure requires the trunk power to be isolated, or a gas clearance certificate to be obtained before any work is carried out.

* NOTE
The standard, non-redundant 9377-FB barrier cannot be fitted in place of the 9377-FB-R; it has built-in mechanical differences to prevent its substitution.

5.2 Fieldbus Barrier maintenance procedures

The 9377-FB Fieldbus Barrier is designed to tolerate the failure of one or more spur circuits in either Fieldbus Barrier module. However, a failed module should be replaced as quickly as possible to avoid any loss of power or communication to the spurs from subsequent failures. If a barrier module has one or more LED indicators showing solid red, meaning that the internal spur circuits have failed (see "Troubleshooting"), then it should be replaced.

5.2.1 Fitting and removal techniques

The individual 9377-FB-R Redundant Fieldbus Barrier module(s) may be fitted or removed without isolating the trunk power. The trunk connections to the barrier module on the carrier have spark suppression by design and cannot cause ignition while they are being connected or disconnected. This section should be read to understand the physical removal or installation of a barrier, but read 5.2.2 on page 16 to understand the recommended procedure for replacing a barrier when powered.

5.2.1.1 Removing a Fieldbus Barrier module (refer to Figure 5.1)

- Loosen the three captive fixing screws (C & D) on the module to release it. The screws are all spring-loaded and should retract when the thread has disengaged.
- Slowly pull the 9377-FB-R Fieldbus Barrier module away from its connections on the carrier until the safety retaining clip (B) stops further removal.
- Press the clip (see bold black arrow) towards the module until the barrier is released and can be removed completely.

5.2.1.2 Fitting a Fieldbus Barrier module (refer to Figure 5.1)

Note: Before fitting a 9377-FB-R Fieldbus Barrier module check the connection pins on its underside to ensure that they have not been bent or damaged in any way.

Do not use, or attempt to repair, a barrier module that has any of its pins *bent or damaged*, because this might affect its safety and will invalidate the certification.

- Engage the locating guides (A) of the 9377-FB-R Fieldbus Barrier module into the sockets provided on the carrier and push the module fully into place.
- Tighten the three captive fixing screws (C & D) to a recommended torque of 0.9Nm to secure it.

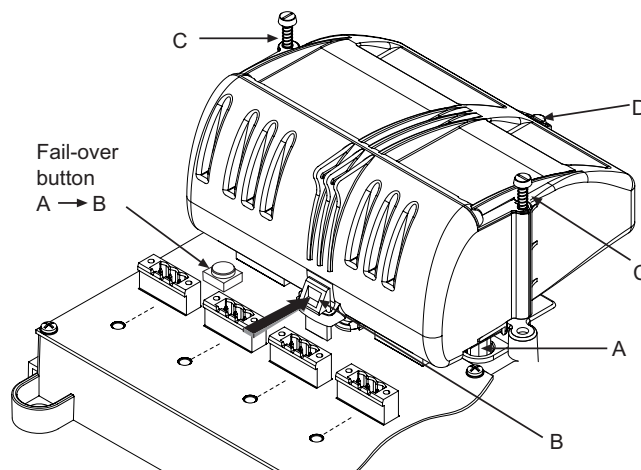

Figure 5.1 - Fieldbus Barrier module – fitting & removal

5.2.2 Use of Fail-over button when replacing a barrier

The following technique is recommended for the replacement of a barrier. Do not remove the 'active' barrier of a redundant pair as this may cause loss of communications to a fieldbus device.

Two fail-over buttons are provided to permit a manual transfer of control status from Active to Standby e.g. A > B or B > A. By switching all spurs to a fully operative barrier module, 'active' operation can be maintained during module replacement.

The following example illustrates a typical "hot-swap" procedure.

Key to symbols in the digram: Note: Only spur LEDs shown for clarity.

- = Active, healthy (solid)
- ★ = Standby, failed (pulse)
- ★ = Standby, healthy (pulse)

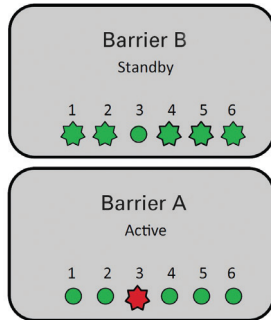

Step 1

1. Spur #3 on Barrier A has failed and shows pulsing red. Control of this spur has transferred automatically to Spur 3 of Barrier B, which has changed from a flashing green to a solid green. Barrier A needs to be replaced to restore redundant service.

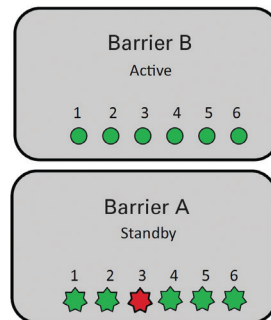

Step 2

2. Press the A > B fail-over button, beside Barrier A, to pass spur control to Barrier B. Barrier B LEDs should all change to solid green and all LEDs on Barrier A should pulse to indicate that Barrier A is now in 'standby' mode and Barrier B has become the 'active' barrier.

3. Barrier A can now be removed from the carrier (following the procedure in Section 5.2.1.1) and replaced with a known good module. After replacement, Barrier A remains in 'standby'.

4. To restore Barrier A to 'active' mode, press the B > A fail-over button located beside Barrier B. Control of all spurs now returns to Barrier A while Barrier B returns to 'standby' mode.

*** NOTE**

Operating the fail-over buttons will not allow active spurs to be transferred to a missing, failed spur or failed barrier module.

5.3 Terminator and Trunk Surge Protection modules

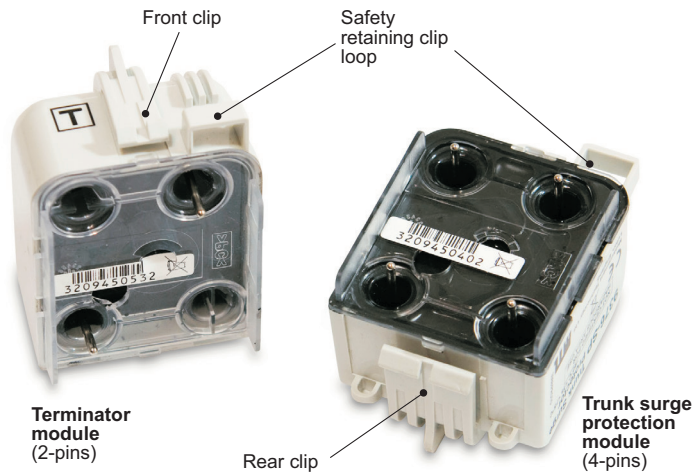

Figure 5.3 - Module connectors and retaining clips

5.3.1 Fitting and removal

Both modules have connectors that are designed to prevent an ignition-capable spark when the module is installed or removed. The modules are not interchangeable but the method of installing and removal is the same.

Do not use, or attempt to repair, a module that has any of the pins on its underside *bent or damaged*, because this might affect its safety and will invalidate the certification.

5.3.1.1 Mounting a module

Refer to Figure 5.4.

Orientate the module so that the smaller front clip is facing the user, then:

- lower the module so that the safety retaining clip on the TTA housing fits into the loop on the module
- locate the terminal pins into their contact sockets on the TTA housing and
- push the module home until front and rear retaining clips engage.

5.3.1.2 Removing a module

Refer to Figures 5.3 and 5.4 for further information.

Removal is a two-step process that first breaks the electrical connection, followed by the physical removal of the module from the TTA.

- Press the clip at the rear of the module and tilt the module forward until the clip disengages at the rear.
- Press the front clip and withdraw the module from its socket until it is stopped by the safety retaining clip, then press down on the safety retaining clip enough to release it and pull the module away from the TTA body without rotating or twisting it.

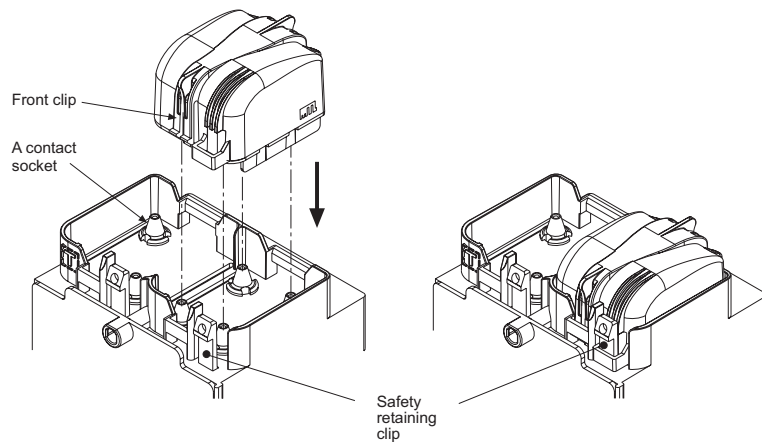

Figure 5.4 - Mounting a module - e.g. Trunk Surge Protection module

5.4 Spur connections

All of the spur connections are intrinsically safe and therefore may be live-worked in a hazardous area without 'gas clearance', while complying with normal 'permit to work' procedures. If spur wiring is removed from a connecting plug, ensure that the same polarity is observed when it is reconnected.

For additional information refer to Section 4.6 on page 13.

5.4.1 Removing a Spur Surge module & spur cable adjustment

If an FS32 Spur Surge module needs to be removed from circuit, it will probably be necessary to increase the cable length inside the enclosure slightly to allow the spur wiring connector to be plugged into the circuit board. Use the following procedure.

- a) Loosen the two screws securing the pluggable, spur-wiring connector to the Spur Surge module and unplug it.
- b) Loosen all three of the Spur Surge module's fixing screws and unplug it from the carrier.
- c) Loosen the spur cable gland.
- d) Pull an additional 20 mm (approx.) of additional cable length into the enclosure.
- e) Plug the spur connecting plug into its mating socket on the barrier carrier and tighten the fixing screws to a recommended torque value of 0.4 Nm.
- f) Finally, make any necessary adjustments to the cable to avoid any tension, then tighten the spur cable gland to clamp the cable to retain the IP rating of the enclosure.

5.4.2 Adding a Spur Surge module & spur cable adjustment

If an FS32 Spur Surge module is added, it will probably be necessary to reduce the cable length inside the enclosure slightly when connecting the spur wiring connector to the Spur Surge module. Refer also to Section 4.6.1 on page 13 for further fitting details.

- a) Loosen the two screws securing the pluggable, spur-wiring connector to the carrier and unplug it.
- b) Plug the Spur Surge module into the vacant socket on the carrier and tighten the two fixing screws and its grounding screw, all to a recommended torque of 0.4 Nm.
- c) Loosen the spur cable gland.
- d) Withdraw approximately 20 mm of the cable length from the enclosure.
- e) Plug the spur connecting plug into its mating socket on the Spur Surge module and tighten the fixing screws to a recommended torque of 0.4 Nm.
- f) Finally, make any necessary adjustments to the cable to avoid any tension, then tighten the spur cable gland to clamp the cable to retain the IP rating of the enclosure.

5.5 Trunk connections

	WARNING!
	No work is permitted on any part of the Trunk Terminal Assembly while the enclosure is powered, unless the environment is known to be non-hazardous.

Before any work starts on the Trunk Terminal Assembly the trunk power to the enclosure must be isolated, or a gas clearance certificate obtained.

Once the conditions are known to be safe, the protective plastic cover of the Trunk Terminal Assembly (TTA) may be removed. Unscrew its securing screw, slide it out until it becomes free and then move it to the side to obtain access.

Refer to Section 4.2 on page 8 and Section 4.3 on page 11 for additional information about trunk wiring connections.

When any changes or checks have been carried out, ensure there are no loose implements left inside the TTA before replacing its protective cover. Slide the cover into its locations and tighten the securing screw to a recommended torque of 0.6 Nm.

5.6 Regular Maintenance checks

Check the general condition of the installation occasionally to ensure that no deterioration has occurred. At least every two years (and more frequently for harsh, dusty or dirty environments) check:

- the condition of all wire connections/terminations/screens.
- that all of the fixing and cover screws and blanking plugs are secure and the breather is clear.
- that there are no signs of damage or corrosion.
- that the level of accumulated dust on the enclosure does not exceed 5mm.

In addition, take advantage of plant maintenance shutdown periods or **whenever the area is known to be non-hazardous**, to check wiring quality by confirming that the dc voltage on the fieldbus trunk, when measured at the enclosure, is >16V. This can be performed using a multimeter or an FBT-6 fieldbus tester.

5.6.1 Proof testing of redundancy mechanism

The Fieldbus Barrier is designed to automatically transfer spurs between the 'active' to the 'standby' barrier modules in the event of internal electronic failures. This mechanism may be proof-tested by manually forcing the transfer of all spurs between the modules using the Fail-over buttons located on the module carrier (see clause 5.2.2 and diagram 5.1). Pressing the A > B button will force all spurs to transfer from module A to module B. Pressing the B > A button will return the spurs to module A.

Operating the Fail-over buttons will reliably transfer all spurs without interrupting the fieldbus communication; however, repeated operation is not advised if the Fieldbus Barrier is operating in a live fieldbus segment. Use of the Fail-over buttons is therefore recommended only for periodic proof-testing during plant shutdowns, and for the purpose of module replacement.

NOTE

Operation of the Fail-over buttons will *not* cause active spurs to be transferred to a missing or failed barrier module.

6 Troubleshooting

The Redundant Fieldbus Barriers are fitted with LED indicators to assist the user in fault identification.

Consult the following tables to understand the meaning of the LED states.



Power LED (Green)

The Fieldbus Barriers inside the enclosure are fitted with LED indicators to assist the user in fault identification. Consult the following tables to understand the meaning of the LED states.

NOTE

The **Power LED** will not light until the voltage at the barrier has risen to a value of at least 15.7V, *but could remain lit even after the voltage has dropped to around 13.0V*. DO NOT assume the Power LED indicates a voltage of 16V or more.

Power LED

Colour	Description	Visual
Green ON steady	Trunk power present	
Green OFF	Insufficient or no trunk power	

NOTE

THE POWER LED WILL NOT LIGHT UNTIL THE VOLTAGE AT THE BARRIER HAS RISEN TO A VALUE OF AT LEAST 15.7V, BUT COULD REMAIN LIT EVEN AFTER THE VOLTAGE HAS DROPPED TO AROUND 13.0V. DO NOT ASSUME THE POWER LED INDICATES A VOLTAGE OF 16V OR MORE.

If the green Power LED is not lit, check:

- the polarity and integrity of the trunk cable connections to the enclosure.
- that the d.c. supply powering the incoming trunk is operating correctly.

Spur LEDs

The following tables show the possible modes of operation of the spur LEDs on the barriers and their associated meanings.

Colour	Description	Visual
Green steady	Active spur, OK	
Green flashing ¹	Active spur, open circuit	
Green pulsed ²	Standby spur, OK	
Yellow flashing ¹	Active spur, short circuit, current limit	
Yellow steady	Active spur, short to shield	
Red pulsed ²	Standby spur, internal fault	
Red steady	Active <u>and</u> standby spurs, internal fault	

Notes:

¹ Two flashes per second

² Short pulses every two seconds

CAUTION

937X-FB Fieldbus Barrier enclosures are designed to operate reliably in industrial environments and comply with international standards for immunity to electromagnetic radiation. However, damage may occur if the apparatus is exposed to extreme levels of radiated electrical noise, for example from "walkie-talkie" radios, or electric arc-welding. If local welding activity is unavoidable, power should first be removed from the Fieldbus Barrier.

7 ALARM MODULE - OPERATION & CONFIGURATION

7.1 Introduction

As with all redundant systems, early notification of the failure of a system component is important so that the fault can be rectified before a second fault is allowed to occur. A second fault is likely to interrupt the process, so restoring redundant operation is vital in maintaining high levels of system availability. With the MTL Fieldbus Barrier, notification of the health of the redundant 9377-FB-R barrier modules can be made available to the host control system via the fieldbus network. Host notification is achieved using an Alarm Module mounted inside the Fieldbus Barrier enclosure. The alarm module is a Foundation Fieldbus Device that is connected to the fieldbus segment using one of the six available spurs in the enclosure, and appears on the segment 'live list' along with other devices that are supported on the segment. The device monitors both fieldbus barrier modules within the field enclosure, and signals the healthy/failed status of each spur via fieldbus Digital Input (DI) function blocks. Each barrier module is assigned its own DI function block; the control system must therefore monitor the status of both DIs in order to detect a spur or a module failure.

The integrated fieldbus device is also able to provide additional diagnostic information that is not normally available in conventional fieldbus barrier installations. Importantly, each of the Fieldbus Barrier modules is able to detect a short-circuit or a low impedance between the plus (+) or minus (-) connections of any spur and the shield (S) of the spur cable. Undetected "short to shield" faults jeopardise the reliability of a fieldbus network, because a second fault may cause the loss of one or more active spurs. With the MTL Redundant Fieldbus Barrier, as well as being indicated by the module's status LEDs, a "short-to-shield" fault is also indicated via status bits contained in the fieldbus alarm module's Analog Input (AI) function blocks. This can therefore give early indication of faults via the fieldbus control system, allowing early rectification.

The fieldbus alarm module also incorporates a temperature sensor, which can, if required, be used to ensure that the ambient temperature around the Fieldbus Barriers does not exceed the 75°C value required to promote reliable operation and compliance with certification requirements.

7.2 Device details

The fieldbus alarm device is an ABB type TTH300. It has a pre-configured device tag "MTL 9372-FB". It contains the following FF blocks:

Function block type	Default Tag name	Use in MTL Alarm application
Resource Block	Resource (RB2)	Alarm module internal temperature, bus voltage, firmware & hardware versions
DI (digital input) Block 1	DI1 (DI)	9377-FB-R module A health status, via PV_D value
DI (digital input) Block 2	DI2 (DI)	9377-FB-R module B health status, via PV_D value
AI (analogue input) Block 1	AI1 (AI)	Not used
AI (analogue input) Block 2	AI2 (AI)	Short-to-shield detection, 9377-FB-R module A, via OUT_D value
AI (analogue input) Block 3	AI3 (AI)	Short-to-shield detection, 9377-FB-R module B, via OUT_D value
AI (analogue input) Block 4	AI4 (AI)	Not used
ePID Block (PID controller with expanded features)	PID (PID)	Not used
AO (analogue output) Block	AO (AO)	Not used

Temperature transducer Block	Temperature (TT)	Alarm module internal temperature (same measurement as in the Resource block)
Extended diagnostics transducer Block	Diagnosis (TED)	Not used, but note that this block drives DI1 and DI2
HMI transducer Block (LCD)	HMI (THMI)	Not used

When supplied as part of a 9372-FB Redundant Fieldbus Barrier or separately as an 9379-ALM alarm module, the device's alarm thresholds are pre-configured to correspond to the output signals of the MTL Fieldbus Barrier modules. Further device configuration is not necessary. The default tag names for each function block are identified in the above table, but maybe user-configured. Function blocks indicated as 'not used' can be ignored.

The block types of interest in the MTL application are as follows:

7.2.1 Resource Block

The Resource Block contains general information relating to the Alarm module. Parameters of use in the MTL application are:

- Bus voltage. This is a measurement of the voltage appearing at the H1 terminals of the alarm module, and is an indication of the health of the Fieldbus Barrier spur to which the module is connected. This voltage will have a value in the range 10.0 to 13.0V.
- Device Temperature. This is the temperature measured inside the alarm module. Note that this measurement is repeated in the Temperature Transducer Block.
- SW version. Firmware version of the alarm module.
- FW version. Hardware version of the alarm module.

7.2.2 DI (digital input) Function Blocks: failure alarm status of 9377-FB-R barrier modules

The two discrete input blocks conform to FF standard FF-891 and are used by the alarm module for cyclic reading out of extended diagnostics information. For the MTL redundant Fieldbus Barrier, the output of the blocks indicate the health of the 9377-FB-R barrier modules as follows:

DI (digital input) Block 1:

PV_D value = 0: 9377-FB-R Barrier Module A healthy

PV_D value = 1: 9377-FB-R Barrier module A one or more spurs failed

DI (digital input) Block 2:

PV_D value = 0: 9377-FB-R Barrier Module B healthy

PV_D value = 1: 9377-FB-R Barrier module B one or more spurs failed

7.2.3 AI (AI (analog input) Function Blocks: spur short-to shield detection

AI blocks 2 and 3 include pre-configured Discrete Output values that indicate the presence of a spur short-to-shield fault, as follows. Note that although the blocks are identified as Analog Input blocks, they each contain a binary 'OUT_D' value. The primary analog 'OUT' values should be ignored.

AI (analogue input) Block 2:

OUT_D value = 0: 9377-FB-R Barrier Module A short-to-shield OK

OUT_D value = 1: 9377-FB-R Barrier Module A short-to-shield fault detected

AI (analogue input) Block 3:

OUT_D value = 0: 9377-FB-R Barrier Module B short-to-shield OK

OUT_D value = 1: 9377-FB-R Barrier Module B short-to-shield fault detected

7.3 Alarm module fitting or replacement

A standard 9372-FB enclosure is supplied with the Alarm module fitted and it is normally connected to Spur 6.

The alarm module, when supplied as a *separate* item, is ready wired with two connectors, a (2-wire) blue connector for the fieldbus 'Spur' connection and a black (3-wire) connector for the 'Alarm' signals from the barriers.

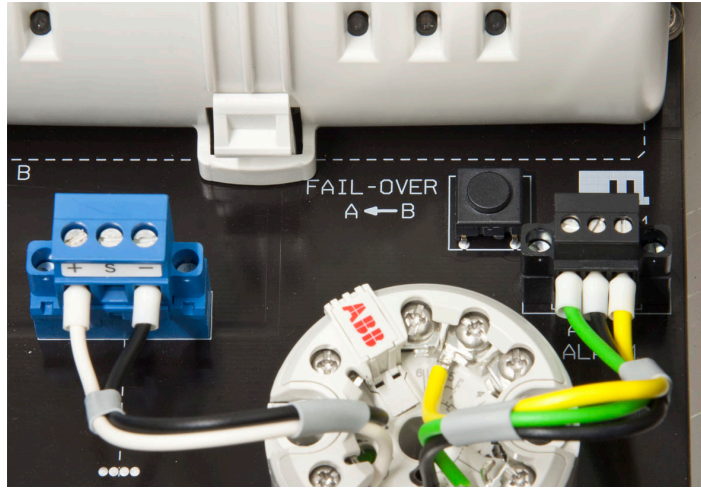

Figure 7.1 - Alarm module wiring connections

NOTE

It is permitted for the alarm module to be removed or installed while the enclosure is powered because all its connections are rated "intrinsically safe".

7.3.1 To remove the alarm module:

1. Loosen the two captive securing screws on the blue (spur) connector and extract the connector - repeat for the black (alarm) connector.
2. Loosen the two captive securing screws on the alarm module and lift it away from the circuit board complete with its wiring and connectors.

7.3.2 To install an alarm module:

The carrier circuit board is designed to provide a mounting for the alarm module beside the Spur 6 connection. Two threaded bosses are provided in the carrier circuit board to mount the module.

CAUTION

Do not exceed 0.4Nm when tightening the following securing screws.

1. Locate the alarm module over the threaded connections on the carrier circuit board and use the captive securing screws to attach the module to the carrier.
2. Insert the blue (2-wire) connector into the Spur 6 socket on the carrier (removing any existing connector first) and tighten the two securing screws.
3. Insert the black connector into the Alarm socket on the carrier (removing any existing connector first) and tighten the two securing screws.

8 ATEX INFORMATION

The Essential Health and Safety Requirements (Annex II) of the EU Directive 2014/34/EU [the ATEX Directive- safety of apparatus] requires that the installation manual of all equipment used in hazardous areas shall contain certain information. This annex is included to ensure that this requirement is met. It complements the information presented in this document and does not conflict with that information. It is only relevant to those locations where the ATEX directives are applicable.

8.1 General

- a) In common with all other electrical apparatus installed in hazardous areas, this apparatus must only be installed, operated and maintained by competent personnel. Such personnel shall have undergone training, which included instruction on the various types of protection and installation practices, the relevant rules and regulations, and on the general principles of area classification. Appropriate refresher training shall be given on a regular basis. [See clause 4.2 of EN 60079-17].
- b) The apparatus has been designed and manufactured so as to provide protection against all the relevant additional hazards referred to in Annex II of the Directive, such as those in clause 1.2.7.
- c) This apparatus has been designed to meet the requirements of electrical apparatus in accordance with EN 60079-0, EN 60079-1, EN 60079-7, EN 60079-11, EN 60079-18 and EN 60079-31.

8.2 Installation

- a) The installation should comply with the appropriate European, national and local regulations, which may include reference to the IEC code of practice IEC 60079-14. In addition particular industries or end users may have specific requirements relating to the safety of their installations and these requirements should also be met. For the majority of installations the Directive 1999/92/EC [the ATEX Directive - safety of installations] is also applicable.
- b) The enclosures are certified:
Ⓔ II 2(1)GD Ex d e ib mb [ia Ga] IICT4 Gb Ex tb IICT80°C Db (−40°C ≤ T_a ≤ +70°C) and are designed for installation in Zone 1 or Zone 2 hazardous areas.
- c) The apparatus must not be subjected to mechanical and thermal stresses in excess of those permitted in the certification documentation, this manual and the product specification.
- d) All cables and their glands must be chosen to withstand the temperatures at which the apparatus is designed to operate. See product specification for details.
- e) The apparatus must not be installed in a position where it may be attacked by aggressive substances.

Read also the Special Conditions for Safe Use (below) for any additional or more specific information.

Special Conditions for Safe Use

1. The equipment shall only be powered from supplies conforming to IEC 61158
2. When a Trunk Surge Module is fitted, due to the presence of transient protection components the power input circuit will not withstand a 500V a.c. isolation test to earth without breakdown occurring.
3. When one or more Spur Surge Modules are fitted, due to the presence of transient protection components the spur outputs will not withstand a 500V a.c. isolation test to earth without breakdown occurring.

8.3 Inspection and maintenance

- a) Inspection and maintenance should be carried out in accordance with European, national and local regulations which may refer to the IEC standard IEC 60079-17. In addition specific industries or end users may have specific requirements which should also be met.

- b) Care should be taken to limit dust accumulation on the exterior of the apparatus to a depth not exceeding 5mm.
- c) Maintenance of internal components while powered is limited to those actions permitted in Section 5 of this manual.

8.4 Repair

The modules used in this product cannot be repaired by the user and must be replaced with an equivalent certified product.

8.5 Marking

Each certified component is marked in compliance with the Directive and CE marked with the Notified Body Identification Number.

This information applies to products manufactured during or after the year 2011.

Product labels
(showing certification
information)

Stainless Steel Enclosure

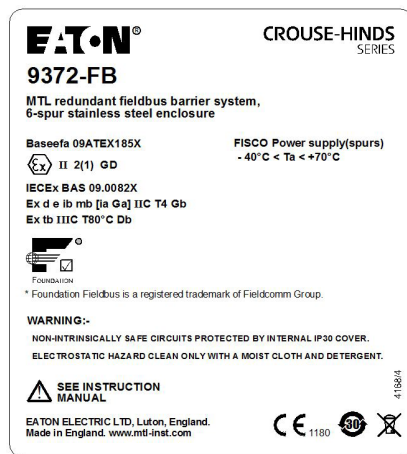

GRP Enclosure

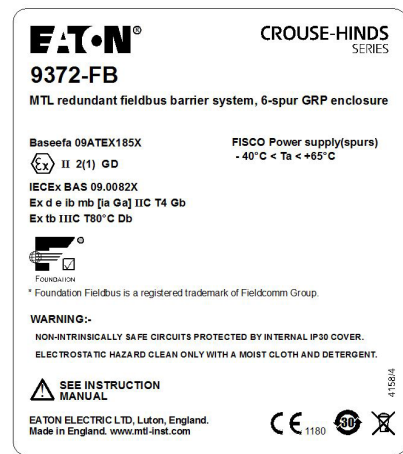

Barrier marking

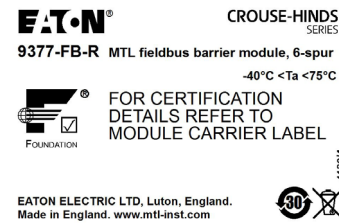

Terminator marking

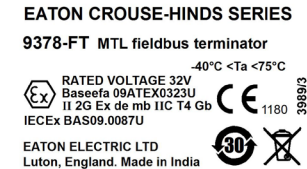

Trunk surge protector marking

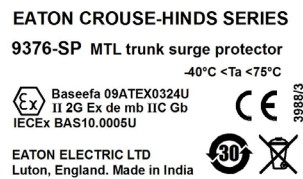

FB Module Carrier



9 APPENDIX 1 - ENCLOSURE WIRING DIAGRAM

Schematic wiring diagram for 9372-FB-Px-YY

Note: Model 9375-FB-Px-YY does not include the Module B Fieldbus Barrier or the Alarm Module (9379-ALM)

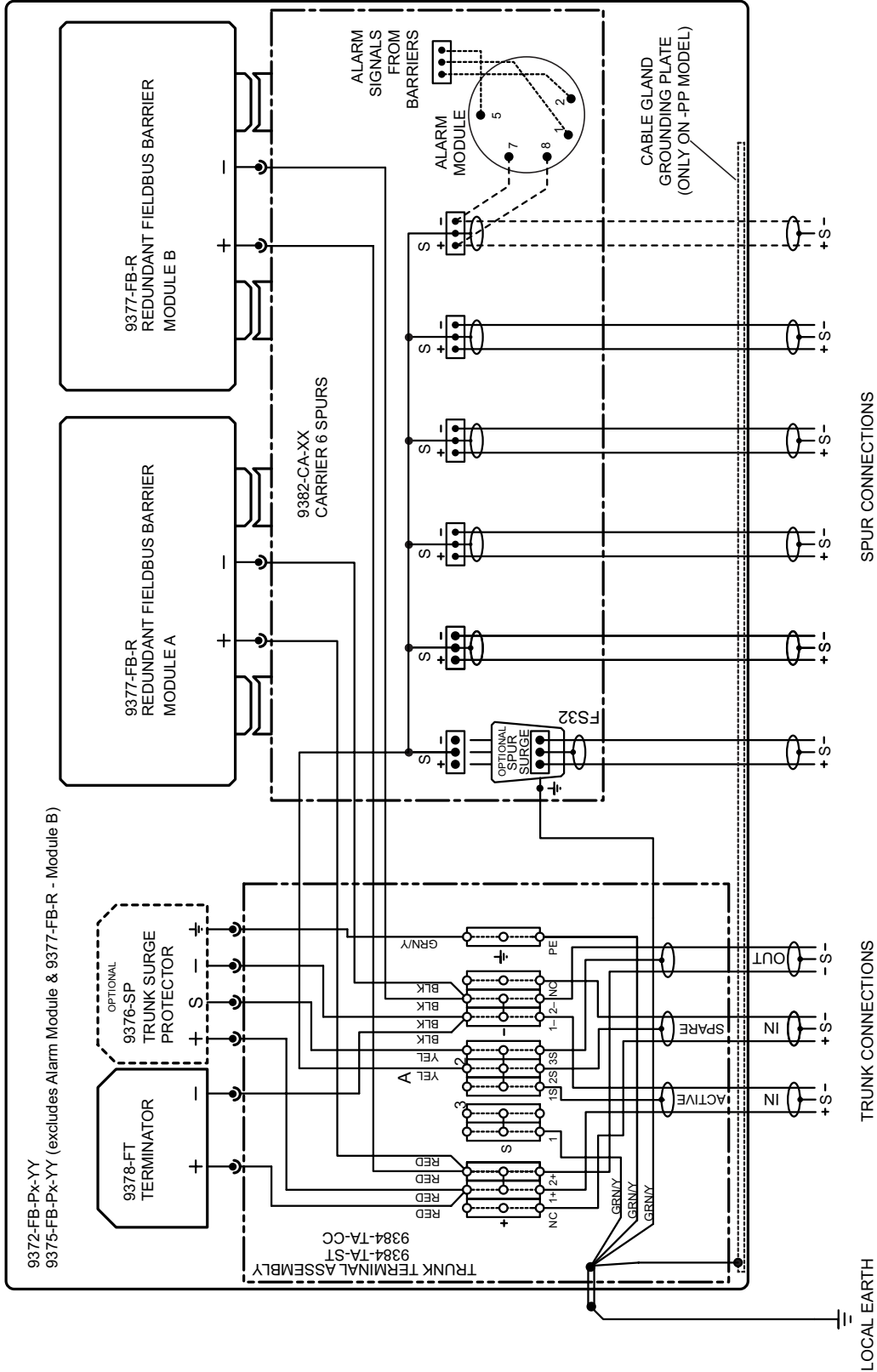

NOTE: CABLE 'A' IS SHOWN IN FACTORY DEFAULT GROUNDING OPTION - I.E. SINGLE POINT GROUNDING AT HOST

This page is left intentionally blank

This page is left intentionally blank

AUSTRALIA

MTL Instruments Pty Ltd,
10 Kent Road, Mascot, New South Wales, 2020, Australia
Tel: +61 1300 308 374 Fax: +61 1300 308 463
E-mail: mtlsalesanz@eaton.com

BeNeLux

MTL Instruments BV
Ambacht 6, 5301 KW Zaltbommel
The Netherlands
Tel: +31 (0)418 570290 Fax: +31 (0)418 541044
E-mail: mtl.benelux@eaton.com

CHINA

Cooper Electric (Shanghai) Co. Ltd
955 Shengli Road, Heqing Industrial Park
Pudong New Area, Shanghai 201201
Tel: +86 21 2899 3817 Fax: +86 21 2899 3992
E-mail: mtl-cn@eaton.com

FRANCE

MTL Instruments sarl,
7 rue des Rosieristes, 69410 Champagne au Mont d'Or
France
Tel: +33 (0)4 37 46 16 53 Fax: +33 (0)4 37 46 17 20
E-mail: mtlfrance@eaton.com

GERMANY

MTL Instruments GmbH,
Heinrich-Hertz-Str. 12, 50170 Kerpen, Germany
Tel: +49 (0)22 73 98 12-0 Fax: +49 (0)22 73 98 12-2 00
E-mail: csckerpen@eaton.com

INDIA

MTL India,
No.36, Nehru Street, Off Old Mahabalipuram Road
Sholinganallur, Chennai- 600 119, India
Tel: +91 (0) 44 24501660 /24501857 Fax: +91 (0) 44 24501463
E-mail: mtlindiasales@eaton.com

ITALY

MTL Italia srl,
Via San Bovio, 3, 20090 Segrate, Milano, Italy
Tel: +39 02 959501 Fax: +39 02 95950759
E-mail: chmninfo@eaton.com

JAPAN

Cooper Crouse-Hinds Japan KK,
MT Building 3F, 2-7-5 Shiba Daimon, Minato-ku,
Tokyo, Japan 105-0012
Tel: +81 (0)3 6430 3128 Fax: +81 (0)3 6430 3129
E-mail: mtl-jp@eaton.com

NORWAY

Norex AS
Fekjan 7c, Postboks 147,
N-1378 Nesbru, Norway
Tel: +47 66 77 43 80 Fax: +47 66 84 55 33
E-mail: info@norex.no

RUSSIA

Cooper Industries Russia LLC
Elektrozavodskaya Str 33
Building 4
Moscow 107076, Russia
Tel: +7 (495) 981 3770 Fax: +7 (495) 981 3771
E-mail: mtlrussia@eaton.com

SINGAPORE

Cooper Crouse-Hinds Pte Ltd
No 2 Serangoon North Avenue 5, #06-01 Fu Yu Building
Singapore 554911
Tel: +65 6 645 9864 / 5 Fax: +65 6 487 7997
E-mail: sales.mtlsing@eaton.com

SOUTH KOREA

Cooper Crouse-Hinds Korea
7F, Parkland Building 237-11 Nonhyun-dong Gangnam-gu,
Seoul 135-546, South Korea.
Tel: +82 6380 4805 Fax: +82 6380 4839
E-mail: mtl-korea@eaton.com

UNITED ARAB EMIRATES

Cooper Industries/Eaton Corporation
Office 205/206, 2nd Floor SJ Towers, off. Old Airport Road,
Abu Dhabi, United Arab Emirates
Tel: +971 2 44 66 840 Fax: +971 2 44 66 841
E-mail: mtlgulf@eaton.com

UNITED KINGDOM

Eaton Electric Ltd,
Great Marlings, Butterfield, Luton
Beds LU2 8DL
Tel: +44 (0)1582 723633 Fax: +44 (0)1582 422283
E-mail: mtlenquiry@eaton.com

AMERICAS

Cooper Crouse-Hinds MTL Inc.
3413 N. Sam Houston Parkway W.
Suite 200, Houston TX 77086, USA
Tel: +1 281-571-8065 Fax: +1 281-571-8069
E-mail: mtl-us-info@eaton.com

Eaton Electric Limited,

Great Marlings, Butterfield, Luton
Beds, LU2 8DL, UK.
Tel: + 44 (0)1582 723633 Fax: + 44 (0)1582 422283
E-mail: mtlenquiry@eaton.com
www.mtl-inst.com

© 2016 Eaton
All Rights Reserved
Publication No. INM 9370-RD Rev 5 041116
November 2016

EUROPE (EMEA):

+44 (0)1582 723633
mtlenquiry@eaton.com

THE AMERICAS:

+1 800 835 7075
mtl-us-info@eaton.com

ASIA-PACIFIC:

+65 6 645 9888
sales.mtlsing@eaton.com

The given data is only intended as a product description and should not be regarded as a legal warranty of properties or guarantee. In the interest of further technical developments, we reserve the right to make design changes.