

FISCO Intrinsically Safe Fieldbus System

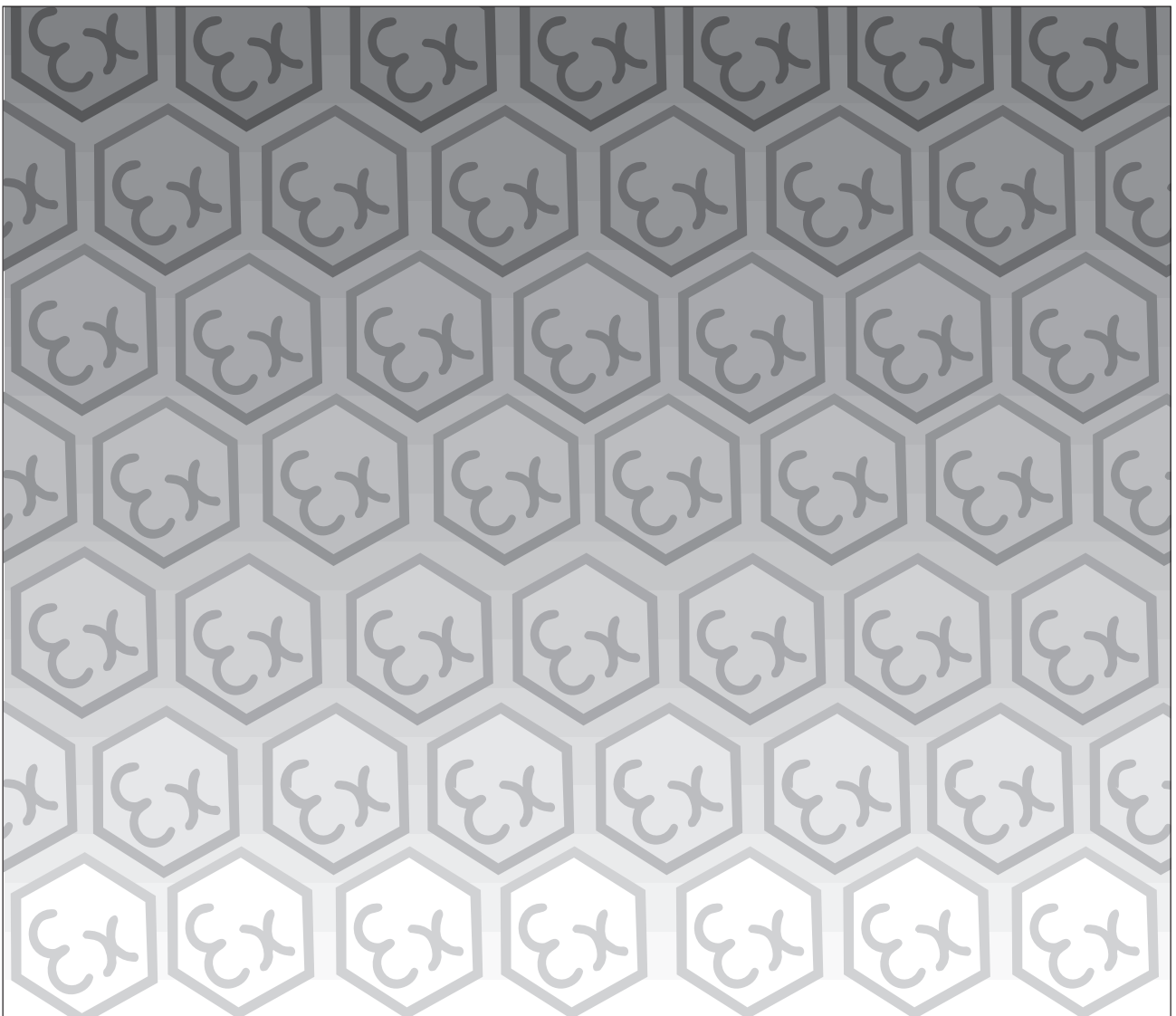

1	INTRODUCTION	1
1.1	About this document	1
1.2	Background	1
1.3	Principle	1
1.4	Cables	1
1.5	Power supplies	1
1.6	Field devices	2
1.7	Documentation and inspection	2
1.8	Conclusion	2
2	POWER SUPPLIES	2
2.1	Introduction	2
2.2	Intrinsically safe output	3
2.3	Host port	3
2.4	24V supply	4
2.5	Screen terminals	4
2.6	Status indicators	4
3	CONNECTING FIELD DEVICES TO A FISCO SUPPLY	4
3.1	Introduction	4
3.2	Output voltage and current	4
3.3	Cable resistance	5
3.4	Field device, voltage and current	5
3.5	Typical calculation for IIC (9121-IS) power supply	6
3.6	Typical calculation for a IIB (9122-IS) power supply	6
3.7	Connecting “Entity certified” field devices	7
3.8	Connecting Zone 0 field devices	8
3.9	Configuration tool	8
4	COMMISSIONING AND FAULT FINDING	8
4.1	Introduction	8
4.2	Facilities	8
4.3	Resistance checks on cable	9
4.4	Specialist test equipment	9
4.5	Procedure	9
5	CABLES AND ACCESSORIES	11
5.1	Cables	11
5.2	Terminators	11
5.3	Interconnection blocks and enclosures	11
6	SURGE PROTECTION	12
6.1	Introduction	12
6.2	Compatible surge protection devices	13
6.3	Protecting the system	13
7	MOUNTING OF FISCO POWER SUPPLIES IN ZONE 2 AND DIVISION 2	15
7.1	General	15
7.2	Typical installation	15
7.3	Mounting of the units in Zone 2 or Division 2	15
7.4	Maintenance and fault finding	16
7.5	Further combinations	16

8	CERTIFICATION AND SAFETY DOCUMENTATION OF FISCO SYSTEMS.....	16
8.1	Introduction.....	16
8.2	MTL FISCO power supplies.....	16
8.3	MTL terminator.....	17
8.4	MTL 24V Zone 2/Division 2 power supply.....	17
8.5	Cables.....	17
8.6	Enclosures and glands.....	17
8.7	Simple apparatus.....	17
8.8	Safety documentation.....	17
8.9	Safety documentation for a FISCO system.....	18
9	APPENDIX I: SIMPLE APPARATUS AND THE ATEX DIRECTIVE.....	19
9.1	Introduction.....	19
9.2	Standards.....	19
9.3	Conclusion.....	19
10	APPENDIX II: EXTRACT FROM BS EN 50020: 2002.....	19

1 INTRODUCTION

1.1 About this document

This application note is a practical guide to the selection, installation and maintenance of equipment complying with the Fieldbus Intrinsically Safe Concept (FISCO). The document begins with a discussion of the origins of FISCO and an introduction to the main elements that should be considered when assembling FISCO systems. Later sections then develop each subject in more detail, with the intention of providing clear guidance to new and experienced fieldbus users.

The document will be updated regularly to reflect changes in practice and to incorporate new information as it emerges. Please make sure you have the most recent version by visiting the MTL website www.mtl-fieldbus.com or contacting your local Eaton representative. (The issue number of this application note is shown on the top right-hand corner of the Contents page.) We welcome comments and constructive criticism of the text, which should be directed by email to AN9026comments@mtl-inst.com

The commonly used term 'H1' is used in the text to describe the low frequency fieldbus (31.25kbits/s) as defined by FOUNDATION fieldbus™.

IEC terminology is used throughout the document when referring to Gas and Apparatus Groups. North American equivalents are as follows:

IEC	North America
IIC (Hydrogen)	Groups A, B
IIB (Ethylene)	Group C

Table 1 - Gas group comparison

1.2 Background

The increase in the use of fieldbus systems in hazardous areas was given a significant boost by the development of an international (IEC) standard for intrinsically safe (IS) fieldbus systems. This standard was based on experimental evidence and theoretical analysis done by the German certification body PTB, and became known as the Fieldbus Intrinsically Safe COnccept (FISCO). The first edition of the full standard (IEC 60079-27) was published in April 2005.

The document is the first significant attempt to simplify the application and documentation requirements of IS systems in the last fifty years. All the standards for explosion protection have become steadily more restrictive and more complex with time, and the FISCO standard is a refreshing departure from this trend.

1.3 Principle

PTB in collaboration with German industry examined the intrinsically safe needs of the 31,25 kbit/s physical layer of fieldbus and developed an approach applicable to both Profibus-PA and FOUNDATION fieldbus™ H1 systems. A PTB report W-53e dated August 1994 provided details of the experimental evidence and the initial thinking on which an IEC document was based. From this proposal, the IEC standard has emerged with only very minor modifications. The result is a comprehensive document, which covers all aspects of a low frequency fieldbus system allowing a system to be built with only minimum analysis of the safety requirements and very simple documentation. The design/manufacture of the apparatus was made slightly more difficult so that the system configuration could be made easier. Arguably this has tended to improve safety as the apparatus is certified, with the manufacturer subjected to surveillance, while system design and installation is less tightly controlled.

The initial IS fieldbus proposal was restricted to 'ia' IIC sources of power, while the FISCO specification permits power supplies to use non-linear regulation and the lower apparatus (gas) group IIB. This makes considerably more power available to the IS trunk and consequently enables more field devices to be supported on each IS trunk.

1.4 Cables

One of the more interesting results of the experimental work was that adding standard instrument cable to a power supply *reduces* the incendivity of the system rather than increasing it. Previously it was assumed that the cable inductance and/or capacitance stored energy would be available to supplement the energy available from the source of power. The experimental evidence however suggests that the cable parameters, because of their distributed nature, modify the form of the test apparatus spark so as to make it less incendive and there is also some theoretical analysis to support this view.

However because the experimental work covers only a limited range of cable parameters, circuit voltage and current, it was considered prudent to limit the acceptable cable parameters in a FISCO IS circuit to those in Table 2.

Parameter	Value
Loop resistance	15Ω/km to 150Ω/km
Loop inductance	0,4mH/km to 1mH/km
Capacitance	45nF/km to 200nF/km
Maximum length of each spur cable	60m in IIC and IIB
Maximum total cable length	1km in IIC and 5km in IIB

Table 2 - FISCO cable parameters

These limits are not restrictive, as a typical fieldbus trunk cable has parameters of 50Ω/km, 0,8mH/km and 120nF/km. The length of the trunk is usually determined by the operational requirements. The restriction of the length of the spurs can occasionally be irritating but if necessary this can be ameliorated by the use of additional current limitation.

In the longer term this work on cables may be applied to the design of all IS systems. This would require further work to determine the limits that are applicable, and consequently for the time being the relaxation is only being applied to fieldbus systems.

1.5 Power supplies

The FISCO standard utilises recent work on the ignition capability of constant current power supplies to propose acceptable levels of power for supplies with a 'rectangular' characteristic, as opposed to those with a falling, resistor-limited characteristic. This permits a greater useable power for the fieldbus trunk, particularly if the less sensitive gas group IIB (Ethylene) meets the installation requirements.

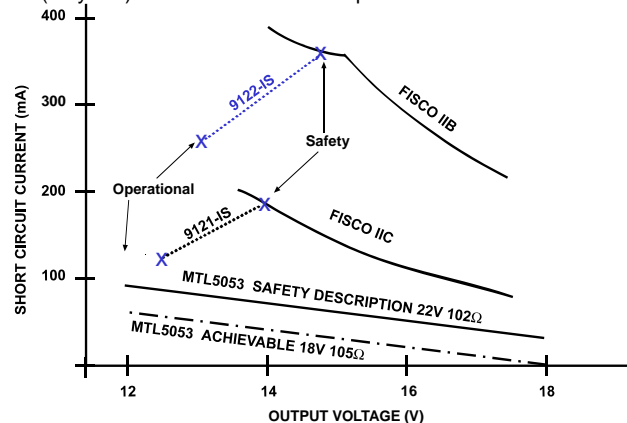

Figure 1 - Current versus voltage curves for fieldbus power supplies

The use of active current limitation restricts the categorisation to 'ib', but it is not usual for a fieldbus trunk to be installed in a Zone 0. Any spur which is directly associated with a Zone 0 can be further protected to achieve 'ia' status. The original Foundation Fieldbus requirement was for a 'IIC ia' power supply, which was very restrictive, as indicated by the curves for the MTL5053 in Figure 1.

The available power is always considerably less than that of the safety description and Figure 1 illustrates the available power achieved by the MTL FISCO power supplies. The calculation of how many field devices can be powered from a power supply is a

relatively simple application of Ohm's Law. The user takes into account the current consumption of each field device, the voltage drop in the trunk cable, and the fact that field devices require 9V to operate. If the assumption is made that the field devices require 20mA and are all at the remote end of the IS trunk, then the number of devices which can be powered from the MTL IIC power supply is five at the end of a 600m trunk. The corresponding IIB power supply will supply twelve devices at the end of a 300m trunk, demonstrating the desirability of a IIB gas classification where that is acceptable. The number of devices connected to a bus is also determined by the plant layout, and by consideration of the system reliability. The number of devices is usually quite low, five or six, with ten being unusual. If the available trunk length is a limitation, moving the repeater power supply into the field, (which may be a Zone 2 or Division 2) may provide a solution.

A typical power supply is as illustrated in Figure 2. This power supply incorporates isolation from its source of power and the host bus, the necessary terminator, and some diagnostic capability. These are not FISCO requirements but are operationally desirable.

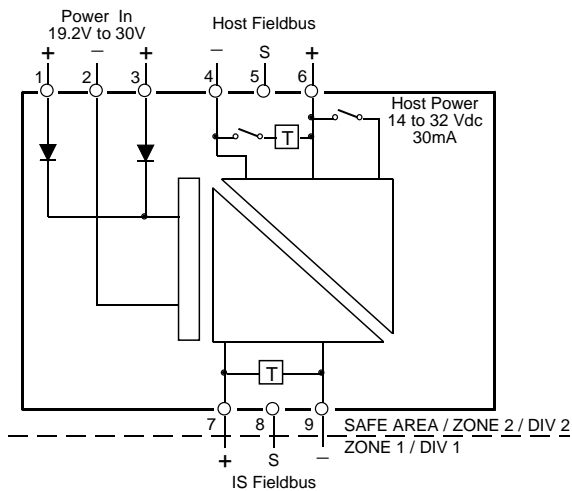

Figure 2 - FISCO power supply

Refer to Section 2 for a more detailed discussion of power supplies for FISCO.

1.6 Field devices

The specification of the fieldbus field devices is determined by the requirement to be compatible with the power supplies and also that additional devices can be added to a system without having to reconsider the system safety. All devices have to be certified IIC and have input parameters of voltage [U_i] 17,5V, current [I_i] 380mA, power [P_i] 5,32W, capacitance [C_i] 5nF and inductance [L_i] 10μH. Devices may have any temperature classification but the majority will be T4 (135°C).

The 5,32W dissipation usually requires some form of power limitation in each device so as to achieve a T4 temperature classification but there are fairly standard methods of doing this without much difficulty. It is possible to utilise devices certified to the original fieldbus specification by introducing some power limitation in the spur. This does however require a small modification to the supporting documentation.

1.7 Documentation and inspection

A major benefit of the FISCO system is that no detailed analysis is necessary to ensure the safety of the system, and additions do not require a reevaluation of the whole system. The gas group of the system is determined by the power supply, and the temperature classification of each piece of apparatus by its certification (usually T4).

The documentation is only a list of the connected apparatus. This is normally done electronically and can readily cross-refer to the certification documents of the apparatus.

A further advantage of this system is that inspection procedure is simplified to ensuring that the system is unchanged and undamaged. Many of the field devices carry a unique identifier and part of the inspection procedure can be done automatically as part of the 'asset management' program. An occasional inspection for mechanical damage is still necessary, but if the equipment is unchanged and operational it is unlikely to be unsafe.

Documentation requirements of FISCO systems are described in more detail in Section 8.

1.8 Conclusion

When a full range of FISCO devices are available it will be possible to assemble a system without a detailed analysis and documentation, confident in the knowledge that it will be safe. It will be simpler and possibly safer than the equivalent conventional system.

The use of non-linear power supplies enables sufficient field devices to be connected to a single trunk, particularly if a IIB gas classification is acceptable.

The FISCO technical specification is the first simplification of explosion protection standards since the rationalisation of the gas grouping. "For these small mercies, much thanks".

2 POWER SUPPLIES

2.1 Introduction

MTL's FISCO power supplies are designed to meet the requirements of the International Electrotechnical Commission (IEC) technical specification IEC 60079-27 and provide power and the signal repeater function for an intrinsically safe bus designed in accordance with that specification.

The basic functions of the power supply are illustrated by Figure 3, which also shows a common but simple application. The power supply is shown mounted in a safe area. It may be mounted in a Zone 2 or Division 2 location, as discussed in Section 7 of this application note.

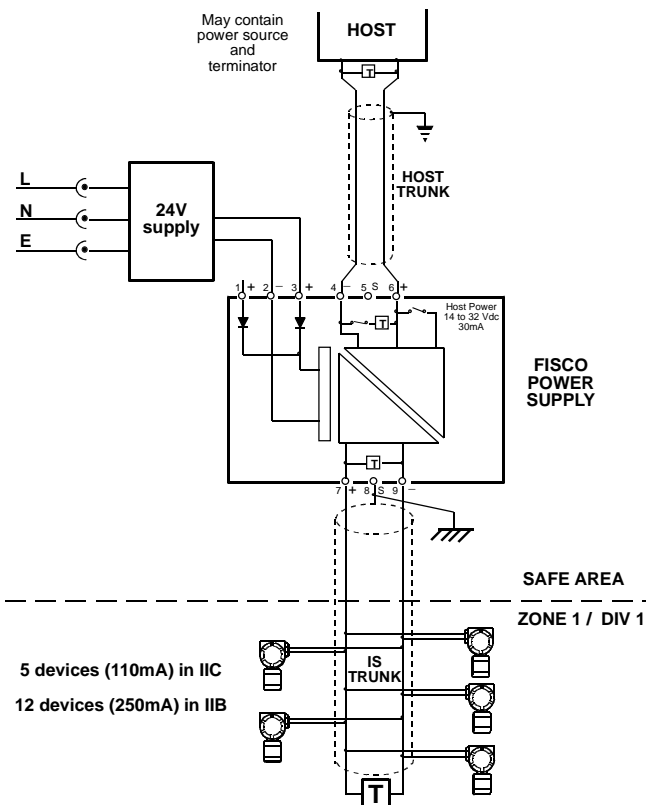

Figure 3 - Block diagram of simple FISCO system

The power supply converts a 24V supply to an intrinsically safe power supply which feeds the IS trunk. The fieldbus signal, which is superimposed on this voltage, is fed into a repeater for transmission to and from the system host.

There are two MTL FISCO power supplies: the 9121-IS is suitable for use where a IIC (hydrogen) apparatus classification is required, and the 9122-IS, where a IIB (ethylene) classification is adequate. They differ only in output characteristics, the IIB version having more output power.

Throughout this document the trunk-cable screens are shown earthed or bonded at a single point.

- The host-trunk screen would normally be connected to the control system earth, which is shown by the symbol \perp .
- The IS-trunk screen would usually be bonded locally to the plant structure, where the FISCO power supply is located, and is shown by the symbol \perp .

This is the usual, but not the only, acceptable practice. The guidance of IEC 60079-14 should be followed at all times.

2.2 Intrinsically safe output

The permitted safety description of FISCO power supplies is defined in the FISCO specification. Both Foundation Fieldbus H1 and Profibus PA organisations have adopted and utilised the specification and the nominated values. The available power is always less than that permitted by the safety description. The FISCO specification clarifies the requirements of constant current power supplies and this permits higher levels of power than that available from a resistive limited source.

Figure 1 illustrated the available power for the different types of power source. The use of constant current power supplies also means that the power dissipated in the unit is much lower and consequently the power supply enclosure can be smaller. (The MTL supplies occupy only 42mm of DIN rail.)

The two lower curves relate to the conventional Foundation Fieldbus source of power (such as the MTL 5053 fieldbus power supply), and the two higher curves relate to supplies with a rectangular safety characteristic such as the 9121-IS and the 9122-IS MTL power supplies. The safety descriptions and useable output of the MTL FISCO power supplies are listed in Table 3.

Model number	Apparatus Class	Safety Description			Useable Output	
		U _o	I _o	P _o	V	mA
9121-IS	IIC	14	180	2,52	12,4	120
9122-IS	IIB	14,8	359	5,31	13,1	265

Table 3 - Power supply output characteristics

These values are indicated on the curves of Figure 1 and interconnected by a broken line. The choice of output voltage is made so as to maximise the number of field devices that can be connected to each power supply.

The use of active semiconductors to limit the current, results in the power supplies being restricted to category 'ib' level of protection in accordance with the IEC apparatus standard. This restriction was imposed because of concern about possible transients, and with the state of knowledge at the time of the decision it was decided that the risk was not acceptable in Zone 0 locations. In practice the MTL power supplies have three stages of voltage limit and two stages of current limit so that they satisfy the US requirements for intrinsically safe apparatus for use in locations which are area classified by Divisions, including areas of continuous hazard.

The bi-directional fieldbus signal has to be developed across the power supply and be transferred to the host port, which repeats the signal to the host. This means that the power supply must have low impedance at low frequencies to give a constant voltage as a source of power, and high impedance at the signal frequency of 31,25kbts/sec. This shaped impedance characteristic is achieved by using an active filter, which must operate without adversely affecting the IS characteristics of the power supply.

The IS trunk must be correctly terminated at each end and a permanently connected terminator for this purpose is included in the power supply.

The IS output is separated from the source of power and the repeated fieldbus signal so as to satisfy the intrinsic safety requirements of isolation to withstand 250V. This three port isolation simplifies the design of the IS system since it removes the possibility of interaction between the circuits. A further advantage is that it removes the possibility of interaction between earth faults on the different circuits, which are frequently the cause of operational faults. This type of fault is extremely difficult to diagnose. Normally the IS fieldbus circuit is operated in a fully floating mode, without any direct connection to earth. A single earth fault unbalances the circuit and introduces some noise. In most cases the circuit continues to operate, but it becomes noisy and less reliable. However the circuit may fail completely. Multiple earth faults on the same circuit invariably lead to operational failure. From an intrinsic safety viewpoint there is a requirement that an intrinsically safe circuit should normally be fully floating or earthed/grounded at one point, and some codes suggest that isolation should be periodically checked. The IS fieldbus circuit is self-checking in respect of multiple earths and hence an isolation check on a functional system is not necessary.

2.3 Host port

The connection for the repeater trunk, which is usually the connection for the host trunk, is a normal fieldbus port. The port requires 9V and a small quiescent current (less than 4mA) to operate. The bi-directional signal transmitted through the repeater is reshaped, thus improving the quality of the transmitted signal. Since the galvanic isolation from the intrinsically safe supply is designed to remain safe when connected to a source with the fault capability of a 250V mains supply (U_m: 250V), there is no requirement for the host or host trunk to conform to any special requirements. Any conventional arrangement is acceptable, and this avoids the special consideration necessary when lower values of U_m are used.

A major advantage of the three-port isolation of the MTL 9121-IS and 9122-IS power supplies is that both the host trunk and the 24V supply can be operated with small common mode voltages or referenced to different earths without any significant interaction between the ports. Normally these connections are earthed or left 'floating', and any common-mode voltages are small (less than 36V). Although the design of the power supplies permits common

mode voltages as high as 250V, their use with high voltages in normal operation introduces a number of practical problems and should be avoided. On those rare occasions where it is unavoidable, then special consideration needs to be given to personnel safety, for example additional marking would be necessary. The presence of high common mode voltages where the power supplies are mounted in Zone 2 or Division 2 requires very special consideration and, although possible, is not recommended.

The MTL 9121-IS and 9122-IS units contain a power supply which can be used to power the host trunk. When the host trunk is powered from the host, the supply in the MTL unit is switched out. This power supply can provide up to 30mA within the permissible voltage range of 14 to 32V, and provides sufficient power to meet the requirements of most existing hosts which do not have a power supply. It is important that a trunk has only one source of power, unless specific attention has been given to ensure that an impedance mismatch or undesirable circulating currents cannot occur. The normal practice is therefore to use a single source of supply, either the host or the power supply in the MTL unit.

In addition the unit contains a terminator which can be switched in to terminate one end of the host trunk. There should only be one terminator at the end of each trunk. Hence where additional field devices or multi-dropped FISCO power supplies use the host trunk, only the MTL unit at the end of the trunk should have its terminator switched in.

The configuration already illustrated in Figure 3 is the usual pattern. However the host trunk can be used to interconnect other devices, including other MTL power supplies. The limitations are usually the amount of data that the host can use, the current available from the host trunk power supply, and the resistance of the host trunk. In practice the small current required by the host port allows the host trunk to be very long (1,8km) unless field devices which require very high standing currents also use this trunk. This attribute is useful if the power supply is used as a repeater to extend the effective trunk length.

2.4 24V supply

Since the intrinsically safe output is also galvanically isolated from the 24V connections with the capability to remain safe with a 250V mains fault, then the unit providing the 24V feed to the FISCO power supplies can be any type of conventional construction. It is recognised that the majority of switch mode power supplies generate high voltages as part of their normal function, but these high voltages have limited potential fault power and apparatus having Um: 250V is considered to be adequately protected against faults from this type of power supply.

The IIC FISCO power supply (9121-IS) requires 190mA at 24V and the fully loaded IIB supply (9122-IS) requires 300mA at 24V. The FISCO power supplies have steering diodes associated with the 24V terminals so that if duplicate 24V supplies are used then a common mode failure due to one supply failing does not occur. The diodes also serve to prevent damage to the FISCO power supply if the 24V supply is accidentally connected the wrong way round.

There are two MTL 24V power supplies suitable for this application. The MTL 5991 operates over the voltage range 85 to 264Vac and supplies a minimum of 1.7A (output current 2A when the supply voltage is greater than 105V). This is more than adequate for the majority of safe area applications. Where a higher power is required or the power supply is to be located in a Zone 2 or Division 2, then the MTL power supply type 8914-PS-AC should be used. This works over the same voltage range, provides up to 10A, and is approved for Division 2 use by FM and certified as Category 3 apparatus in Zone 2 in accordance with the ATEX Directive. For more information on these power supplies see their individual data sheets available on www.mtl-inst.com.

2.5 Screen terminals

Terminals are provided for anchoring the screens/shields of both the trunk cables. These terminals are not electrically connected to anything inside the module, and only provide mechanical support. The recommended practice is to secure a braided screen in a ferrule and secure it in the terminal. The drain wire of a wrapped screen is normally secured by the terminal and the end of the cable sleeved to tidy up the exposed wrapping.

The screens should be earthed/grounded at one end. Usually the IS trunk screen should be earthed at the FISCO power supply and the host trunk screen earthed at the host.

2.6 Status indicators

There are four LEDs on the front of the MTL FISCO power supplies, and these can be used to establish the status of a system. The green LED, marked 'Pwr' (power) indicates that the voltage across the intrinsically safe trunk output is present, thus confirming that input power is present and the power supply is functioning.

The red LED marked 'Fault' is lit when the current limit on the intrinsically safe supply is activated. The most probable cause is either a fault on the cable or attempting to operate too many field devices from the IS output. A quick initial check is to unplug the IS output and the power supply should recover.

The two yellow LEDs marked Host and IS are both permanently on if the data chain on their respective trunks is healthy. If there are data communication errors the LEDs will either turn off or flash intermittently.

A satisfactory installation should have the green power LED and the two yellow signal monitors permanently on and the red fault LED extinguished. The power supply thus provides a good basis for the initial analysis of the status of the system.

3 CONNECTING FIELD DEVICES TO A FISCO SUPPLY

3.1 Introduction

This section considers how to design a working system using MTL FISCO power supplies. The principal requirement is to ensure that there is an adequate voltage at the field device terminals to ensure that it will function correctly. The necessary calculation is a simple application of Ohm's law, using the power supply operational output voltage and output current, the cable resistance, the operating current of the field device and the minimum operating voltage of the field device. Each of these factors can be considered separately.

3.2 Output voltage and current

The minimum useable output voltage and current from the two FISCO power supplies are listed in Table 4.

Type number	Apparatus class	Useable output	
		Volts (V)	Current (mA)
9121-IS	IIC	12,4	120
9122-IS	IIB	13,1	265

Table 4 - Useable output from FISCO power supplies

The output current determines the maximum number of field devices that can be connected to the power supply even with relatively short trunk installations.

Note: The output voltage specified is at 25°C, and is used in all subsequent calculations since it represents a reasonable approach to the majority of installations. The power supplies have a positive temperature coefficient of 12mV/°C, which should be considered if the power supplies are operated at lower temperatures. If the power supply and fieldbus cable are operated at low temperatures, the reduced resistance of the cable counteracts the lower output from the supply.

3.3 Cable resistance

The FISCO technical specification IEC 60079-27 requires that cables comply with the following parameters:

Parameter	Value
Loop resistance	15Ω/km to 150Ω/km
Loop inductance	0,4mH/km to 1mH/km
Capacitance	45nF/km to 200nF/km
Maximum length of each spur cable	60m in IIC and IIB
Maximum total cable length	1km in IIC and 5km in IIB

Table 5 - FISCO cable parameters

These requirements must be met but are not usually a significant limitation as all commonly used instrument cable complies with the cable parameters specified. (Typically 50 Ω/km, 0,8 mH/km and 120nF/km). Occasionally the limitation on spur length is a slight inconvenience but this can be usually overcome by careful positioning of the field junction box.

Existing conventional wiring may be used for fieldbus installations, and frequently proves adequate. Where specialist cable is installed it is designed to meet the 100Ω characteristic impedance requirement and is usually a screened, balanced, multi-stranded twisted pair. The American version is normally seven strands of 18 AWG, which has a loop resistance slightly less than 50Ω/km. The European version is of similar multi-strand construction, equivalent to 1mm in diameter, having a maximum resistance of 44Ω/km at 60°C. For the purpose of the example calculations in this application note the cable resistance is assumed to be 50Ω/km since this is a reasonably practical figure.

3.4 Field device, voltage and current

All fieldbus devices should operate satisfactorily with an average of 9V at their terminals. It is desirable to have a small margin above this, but the example calculations use this minimum figure.

The standing current required by field devices varies considerably. A survey of currently available devices suggests a range from 10 to 28mA with the majority requiring slightly less than 20mA. The number of devices which can be powered from a given source is largely determined by the current required and even a small change can have a significant effect on the length of cable permitted or the number of devices which can be connected. Where possible, the actual current consumption of the field devices in a system should be used to determine its acceptability. A figure of 20mA per device is used in the illustrative examples since this gives a reasonably prudent answer.

If the average current required is reduced from 20mA to 15mA per device, the number of devices that can be connected to the 9121-IS (IIC) power supply increases from six to eight, and from thirteen to seventeen for the 9122-IS (IIB) supply. This does not change the useable trunk length significantly.

Figure 4 and Figure 5 illustrate the idealised voltage and current waveforms on the terminals of a field device. It is the average value of the current drawn that is relevant to the power supply performance. Similarly it is an average voltage of 9V which is required at the field device terminals.

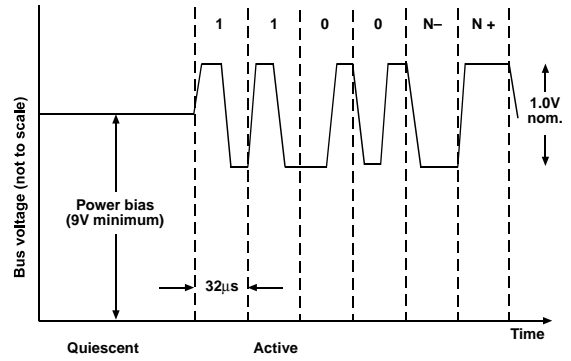

Figure 4 - Idealised voltage waveform of field device

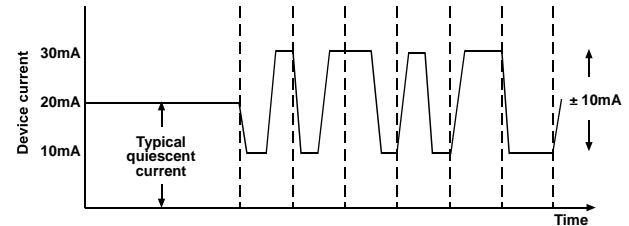

Figure 5 - Idealised current waveform of field device

For the majority of field devices the average current and the quiescent current are the same value. However when the quiescent current is below 10 mA the transmitting current is asymmetrical about the quiescent current and the average current rises to approximately 10mA. This phenomenon is illustrated in Figure 6 and should be taken into account when calculating the viability of a system utilising low current devices. The increase in current is only relevant to the one active device in a system, and can be taken into account by adding 10mA to the total current consumed by the system.

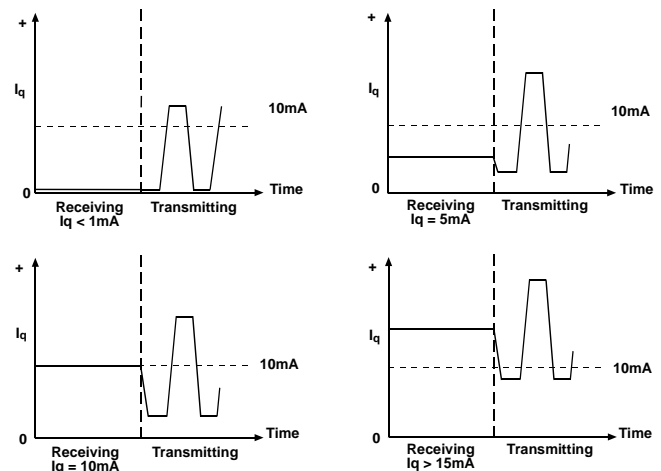

Figure 6 - Field device current waveforms

3.5 Typical calculation for IIC (9121-IS) power supply

The information necessary to be able to calculate whether a system will operate is the average current drawn by each of the field devices, and the resistance of the trunk cable.

A configuration, which is frequently used and is a simple illustration of the necessary calculation to determine operational capability, is shown in Figure 7.

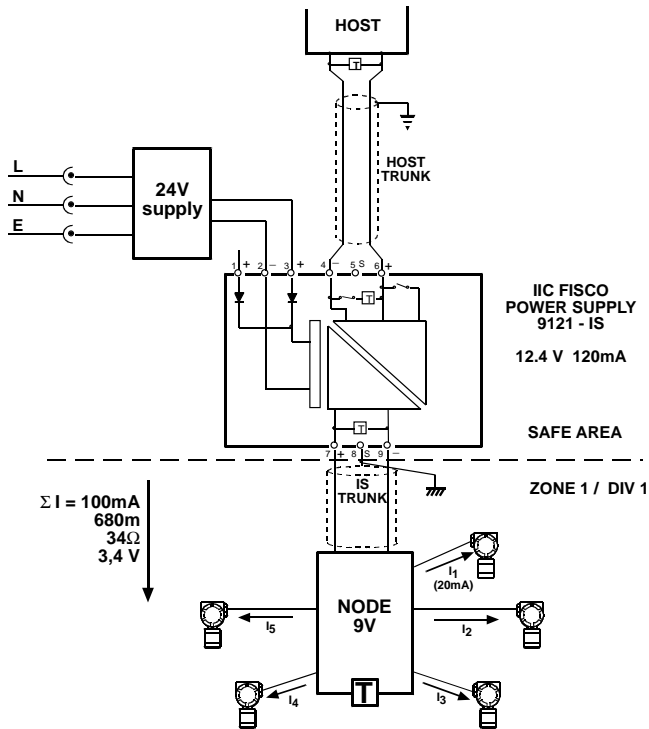

Figure 7 - IIC FISCO power supply with five field devices at end of IS trunk

Figure 7 illustrates a system with five field devices on spurs at the remote end of an intrinsically safe trunk. The first requirement is to ensure that the total current requirement of the field devices is not greater than the output capability of the power supply (120mA). If it is assumed that each field device requires an average current of 20mA then the maximum number of devices that can be powered from the IIC power supply is five as illustrated. The calculation of the maximum acceptable length of the IS trunk is then as follows:

Acceptable voltage drop in trunk = Supply voltage – Minimum operating voltage of field devices

$$= 12,4V - 9V$$

$$= 3,4V$$

Total current in trunk = Number of field devices x Average current per device

$$= 5 \times 20mA$$

$$= 100mA$$

Maximum resistance of trunk = Acceptable voltage drop ÷ Total current in trunk

$$= 3,4 \div 0,1$$

$$= 34\Omega$$

Maximum length of trunk = Maximum resistance of trunk ÷ Resistance per km of trunk

$$= 34 \div 50$$

$$= 0,68 \text{ km (680m)}$$

The spurs are restricted to 60m by the FISCO standard and hence have a resistance of less than 3 ohms and produce a voltage drop of 60mV when carrying 20mA. Except in the cases where the distribution unit contains voltage-dropping components, the voltage drop in the spur can be ignored and hence the system will work if the trunk is less than 680m long. A similar calculation can be made using a different number of field devices, or devices using different currents. The two criteria to be applied are that the total current drawn must not exceed 120mA and the voltage drop on the trunk must not exceed 3,4V. For example, the trunk lengths corresponding to six and three devices are 560m, and 1130m respectively. Assuming that all the devices are at the remote end of the trunk gives a simple calculation and a pessimistic answer, which ensures that the system will work. It is the usual practice to do this calculation first and only resort to doing the more precise calculation if the simple calculation gives an unsatisfactory answer.

There are a large number of variations on the interconnection of field devices to the trunk and the operational requirements can always be analysed by the application of Ohm's law. Figure 8 illustrates a possible configuration and demonstrates that if some of the field devices are moved closer to the power supply then the permissible length of the trunk increases. If the devices are distributed at equal intervals along the trunk, the voltage drop on each section decreases as the total current carried by that section of the trunk decreases. The resultant pattern that emerges is illustrated on the diagram and the total trunk length increases to 750m.

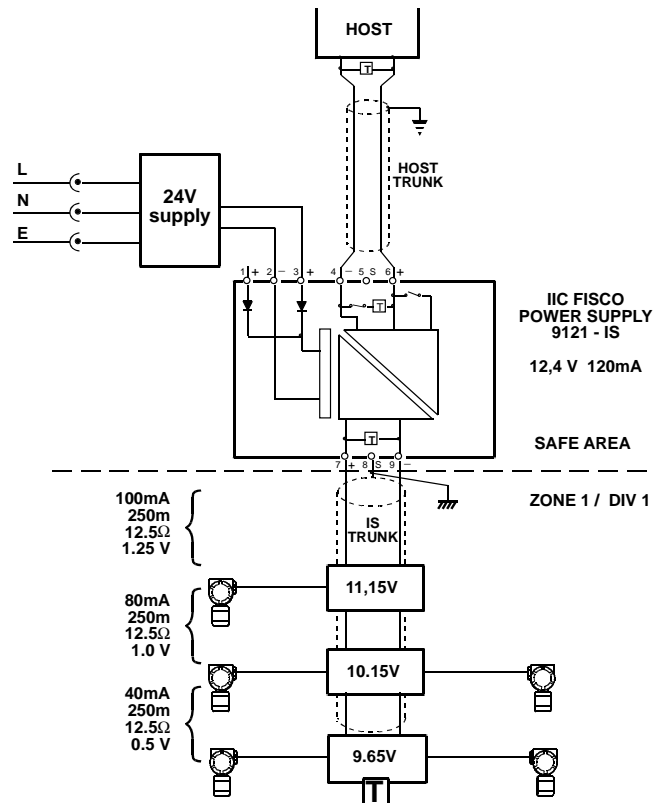

Figure 8 - IIC FISCO power supply with five field devices distributed along length of IS trunk

3.6 Typical calculation for a IIB (9122-IS) power supply

The IIB power supply has minimum output parameters of 13,1V and 265mA at 25°C for operational purposes. If the assumptions of the previous calculations are applied then the maximum number of field devices that can be supplied is thirteen. When twelve devices are concentrated at the remote end of the trunk as indicated in Figure 9 then the calculation follows the pattern of Figure 7 and the available voltage drop on the trunk is 4,1V, and the permitted trunk length is 340m.

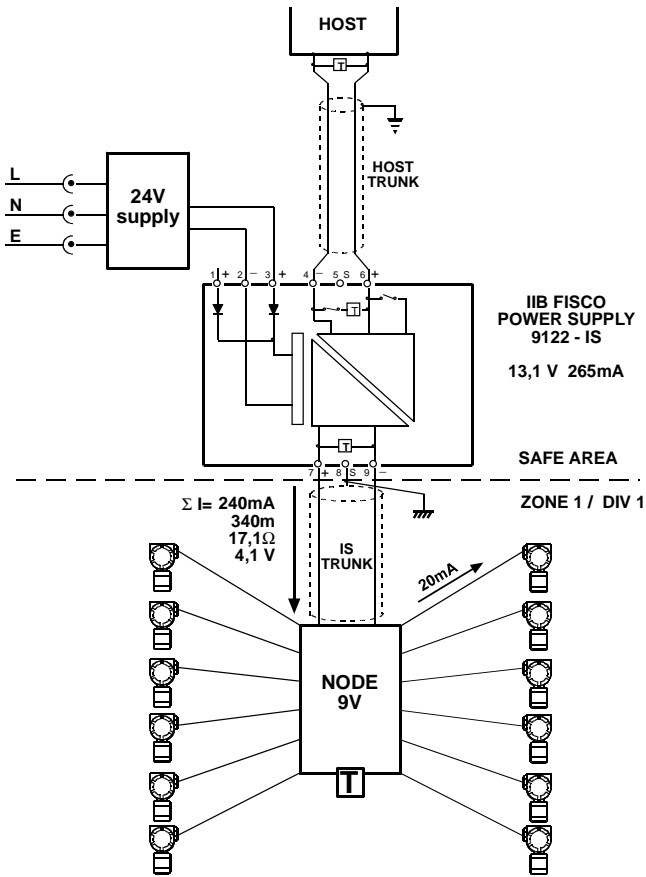

Figure 9 - IIB FISCO power supply with twelve field devices at end of IS trunk

An increased trunk length becomes available if the number of field devices is reduced, and the pattern shown in Table 6 emerges.

Number of field devices	Length of IS trunk (m)
4	1025
5	820
6	683
7	585
8	512
9	455
10	410
11	372
12	340

Table 6 - Relationship between trunk length and number of devices

There are a very large number of possible combinations of field devices with the IIB power supply. It is probable that the simple calculation assuming that the devices are concentrated at the end of the trunk will give a satisfactory answer, which ensures that the system will work. A more detailed calculation taking into account the different voltage drops can be made if this proves to be necessary. Figure 10 illustrates this type of calculation with the field devices split into two groups of six with one group 200m along the trunk, and the second group positioned a further 200m along the trunk.

The first 200m of the trunk carries the current for all twelve devices (240mA through 10Ω) and drops 2,4V, which gives a minimum voltage of 10,7V at the first node. The second part of the trunk carries 120mA and drops a further 1,2V giving a minimum voltage of 9,5V at the final node. This is adequate and hence the system is operationally satisfactory.

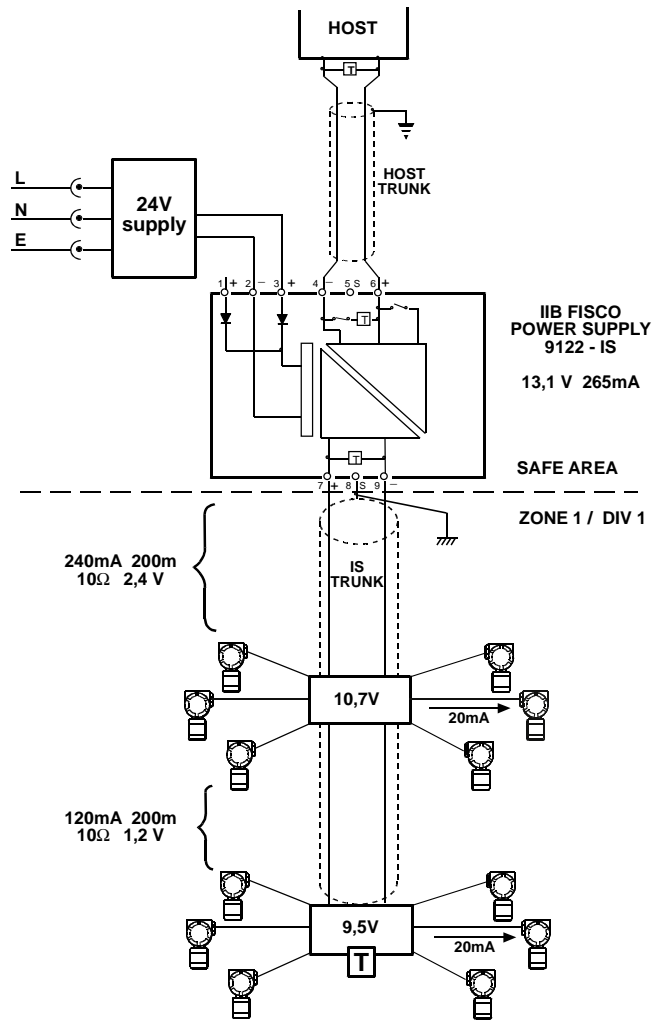

Figure 10 - IIB FISCO power supply with twelve field devices split into two nodes on the IS trunk

3.7 Connecting "Entity certified" field devices

So far, we have considered only FISCO certified field devices. If field devices certified to the FF816 Entity physical layer standard are required to be added to a FISCO segment, power to the device will need to be limited. This is to ensure compatibility with the Entity certification, which specifies a safety description of 24V, 250mA and 1.2W. The maximum output power of the 9121-IS and the 9122-IS (as specified in the safety description) is 2.52W and 5.31W respectively, so to protect the Entity certified field device, a limiting device must be interposed in its connection to the segment.

The 9321-SC and the 9323-SC spur connectors provide this limiting action and should be chosen to suit the gas group(s) involved. Use Table 7 to choose the appropriate one. One spur connector is required for each Entity-certified field device. It would typically be mounted inside the junction box that contains the Megablock wiring hub. Note that the 9323-SC may be used with the 9121-IS or 9122-IS FISCO power supplies.

Table 7 - Choosing a spur connector for the appropriate gas group

Gas group	FISCO power supply	
	9121-IS	9122-IS
IIC / A & B	9321-SC	-
IIB / C & D	9323-SC	9323-SC

Figure 11 and Figure 12 illustrate the use of the spur connectors in the field for the gas group types.

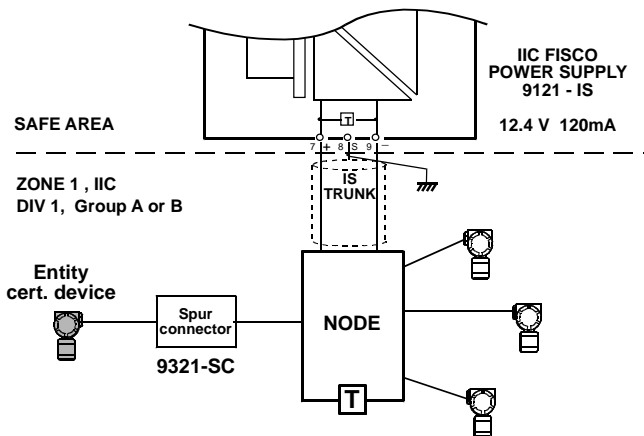

Figure 11 - Use of the 9321-SC spur connector in IIC/A,B applications

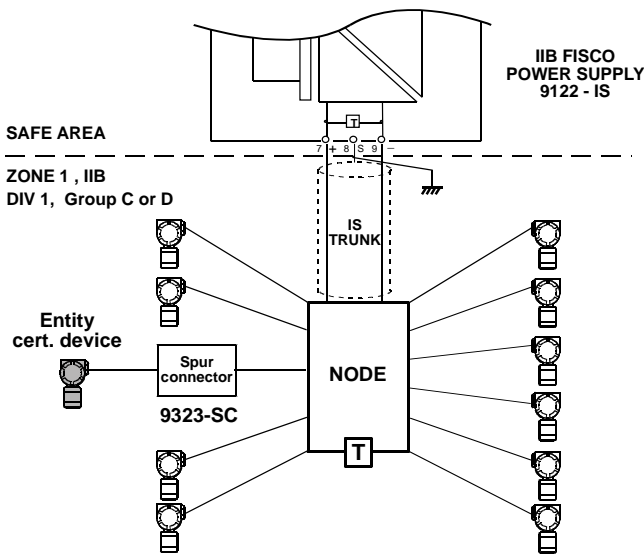

Figure 12 - Use of the 9323-SC spur connector in IIB/C,D applications

Both the 9321-SC and the 9323-SC are designed for DIN rail mounting. The 9321 is nominally 64mm square and occupies 18mm of rail length, while the 9323-SC is 105mm wide by 90mm high and uses 12.6mm of rail length.

3.8 Connecting Zone 0 field devices

Some fieldbus applications have devices located in Zone 0, or have an electrical connection into Zone 0 that requires EEx ia certification. The MTL FISCO power supplies may not be connected directly into Zone 0 because their hazardous area output carries Ex ib certification.

The 9322-SC spur connector provides an EEx ia protected spur from an Ex ib trunk, and can be used with either the 9121-IS or the 9122-IS FISCO power supply. See Figure 13.

One spur connector is required for each field device in Zone 0.

Note: The 9322-SC must not be confused with a conventional EEx ia barrier, which limits both voltage and current. The 9322-SC limits the current only, as the voltage is already limited by the 912X-IS FISCO power supply.

Like the 9321-SC, the 9322-SC is approximately 64mm square and uses 18mm of DIN rail length.

3.9 Configuration tool

The Ohm's Law calculations considered so far in this chapter may be automated by using a software-based configuration tool. We have such a tool, which may be downloaded from the website www.mtl-inst.com. The 9121-IS and 9122-IS FISCO power supplies are supported, together with the 'Megablock' range of wiring hubs and 'Entity' and 'Ex ia' spur connectors.

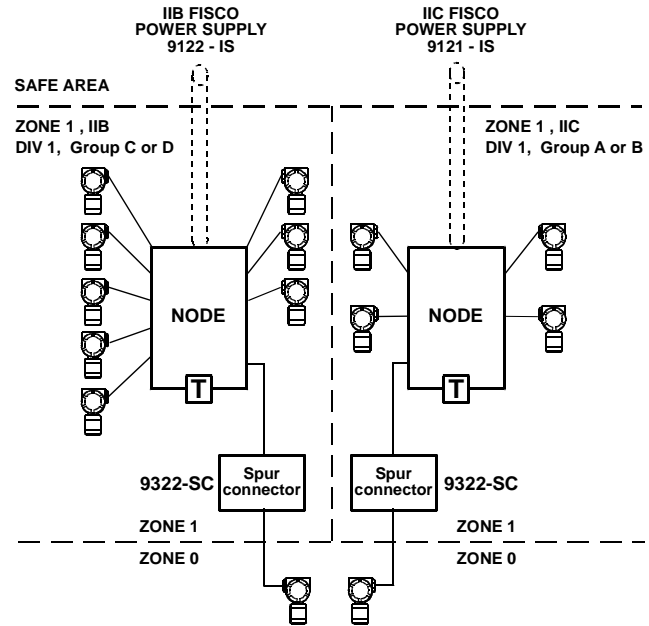

Figure 13 - Use of the 9322-SC EEx ia spur connector for Zone 0 field devices

4 COMMISSIONING AND FAULT FINDING

4.1 Introduction

A major advantage of an intrinsically safe system is that it may be worked on in a hazardous area without switching it off or obtaining a gas clearance certificate. Clause 4.6.2 of IEC/EN 60079-17 details the permitted activities. These are the removal and replacing of apparatus and modules and the use of appropriate test equipment. This enables the diagnosis of faults and their correction to be accomplished quite readily.

It is not a practical proposition nor permitted to carry out detailed fault finding on the apparatus within an intrinsically safe circuit when it is in or connected to the hazardous area. Major repairs to any intrinsically safe apparatus may affect the level of safety provided and invalidate the certification. In general, only the manufacturer or his authorised representative should effect repair.

This section assumes that the power supply is mounted in a safe (non-hazardous) area. When the power supply is used in a Zone 2 or Division 2 location then the procedure is slightly modified. The slightly different requirements are discussed in section 7 of this application note

4.2 Facilities

The MTL FISCO power supplies have system status indicators to aid fault diagnosis. A further useful feature is that all the interconnections are made using plug in terminals, which makes disconnection and correct reconnection relatively easy. The plugs are designed to fit securely, and should be removed using a small screwdriver as a lever as illustrated by Figure 14. (The Zone 2 and Division 2 standards require the plugs and sockets to have a considerable extraction force and this is also desirable from an operational reliability viewpoint).

A spare set of plugs could be procured for the FISCO power supply, to make testing of the power supply and reconnection of the existing wiring easier. A single plug with the polarising strips removed will fit into any of the sockets but this could lead to subsequent misuse and the utilisation of a full set of plugs is the recommended practice.

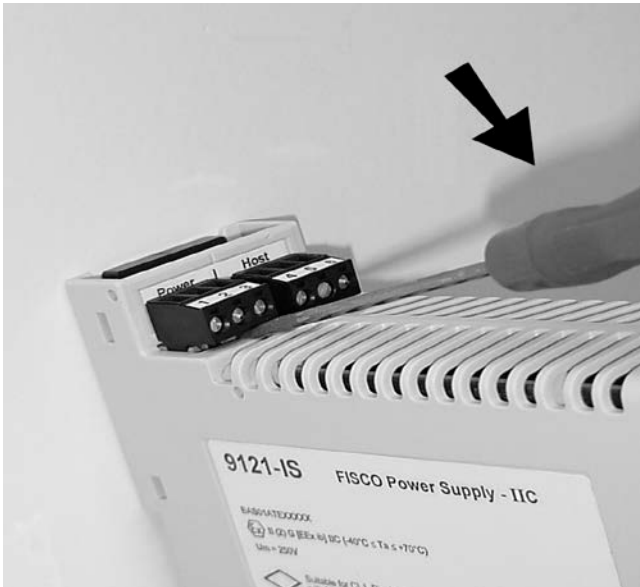

Figure 14 - Disconnection of FISCO power supply terminal block

4.3 Resistance checks on cable

A simple resistance check on each installed cable before connecting it to equipment is desirable since this can save a considerable amount of time. This is best carried out using a certified intrinsically safe tester, since this reduces the possibility of making an error when testing the cable in the hazardous area. There are a number of such testers commercially available.

The insulation checks on a screened twisted pair should be between the wires, from each wire to the screen, and from the screen to the structure. Values greater than 100kΩ should be achieved on a new installation, but the system should operate with values above 10kΩ. The insulation test is carried out at a low voltage but this is satisfactory for this purpose.

In addition, the loop resistance of the cable should be checked by shorting one end of the pair. The acceptable value is determined by the value used in the calculation to demonstrate the feasibility of the intended interconnection of equipment. It should be remembered that copper has a relatively high temperature coefficient of resistance (+20% for 25°C rise) if the wiring is to be subjected to significant changes in ambient temperature.

4.4 Specialist test equipment

None of the currently available specialist test equipment is certified for connection to the intrinsically safe part of the circuit, without obtaining a gas clearance certificate. This test equipment can be used effectively on the safe area side of the power supply and to apply tests to the intrinsically safe terminals when the intrinsically safe circuit is disconnected.

When connected across an active bus, the FBT-3 fieldbus monitor (Figure 15) checks:

- the voltage across the bus (>9V).
- the signal level of the Probe Node frame from the Link Active Scheduler (>150mV).
- the number of devices on the network and also any additions or removals.
- the signal level and identity of the device with the lowest signal level (>150mV).
- the average noise level (<75mV).
- the peak noise level (<75mV).
- the signal level of a new devices response (>150mV).

The monitored function is selected by scrolling through using the 'Mode' selection button on the front of the device. Although signal levels greater than 150mV are acceptable, they will be typically in the range 500 to 900mV.

Note that the FBT-3 monitor draws approximately 10mA from the bus and could exceed the segment capacity in marginal systems, possibly resulting in the loss of communication to other devices. A good practice during the design phase would be to anticipate the load presented by the monitor.

The FBT-5 fieldbus wiring validator supplies the power and a test signal so that when used with the FBT-3 the suitability of wiring to be used in a fieldbus system can be checked. It is unlikely that a newly installed cable using one of the fieldbus specified cables will cause any difficulty. However if an existing cable with less well-defined parameters is to be used, then a check of its transmission qualities is prudent.



Figure 15 - FBT-3 - Fieldbus monitor



Figure 16 - FBT-5 - Fieldbus wiring validator

4.5 Procedure

It is not possible to write a fault-finding procedure that is applicable to all the possible configurations of a FISCO intrinsically safe system. The normal techniques of checking the power supplies and the presence of signals are equally applicable to fieldbus systems as they are to almost all other systems. This section suggests a possible way of checking some of the functions of the system. The host would usually first detect the failure of the system, and in some cases indicate which of the field devices is defective.

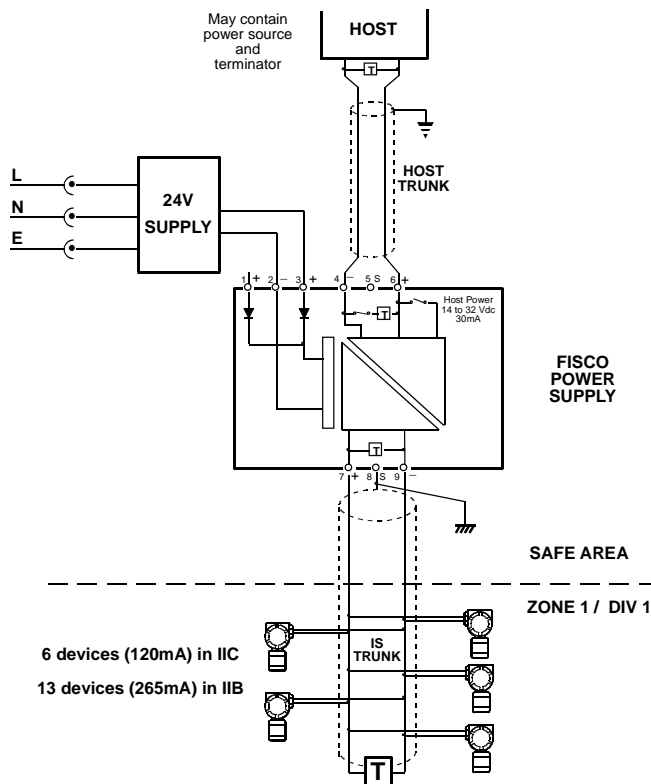

Figure 17 - Diagram of simple system

The following notes based on the simple system illustrated by Figure 17 may prove helpful.

4.5.1 24V supply check

Usually the 24V supply has some indication that it is present. In the specific case of the MTL 5991 and the 8914-PS-AC, both supplies have LEDs on the top surface of the unit, which indicate that the output power is present. If this indication is absent then the presence of the mains supply should be checked. If this is satisfactory then the load on the power supply should be removed by unplugging the 24V output terminals. If the LED indication reappears then the power supply is overloaded and the power supply is probably not at fault. The presence of the 24V supply at the FISCO power supply input terminals can be checked by using the FBT-3 in the relevant mode or any other multimeter.

4.5.2 FISCO power supply

The LED indicators on the power supply enable its operation to be readily checked.

The green LED marked 'Pwr' is connected across the intrinsically safe output and should be *on* at all times, indicating that the dc volts are present at the IS trunk terminals. This can be confirmed by removing the IS trunk plug and measuring the voltage with the FBT-3. It is important to disconnect the IS trunk before using the FBT-3, since the FBT-3 is not suitably certified. Measurements on the connected IS trunk can be made using one of the commercially available certified multimeters. The most common cause of the absence of voltage on the IS trunk is the absence of the 24V supply to the input.

The red LED marked 'Fault' is illuminated when the supply to the IS trunk goes into current limit. If disconnecting the IS trunk plug extinguishes the LED, then the probable causes are a short circuit of the IS trunk or attempting to supply too many field devices. Selective disconnection of the field devices usually reveals the source of the problem. When first switched on the FISCO power supply may go into current limit as some field devices have a high starting current, but if no other faults are present the system will start and the fault indication is removed as the line voltage recovers.

The yellow LED marked 'Host' is normally *on* if the data on the host trunk are healthy. If there is a problem then the LED is either extinguished or flashes, depending on the nature of the fault. The FBT-3 can be used to assist in diagnosing the nature of the fault.

The yellow LED, marked IS, monitors the data on the IS trunk in a similar manner, being normally *on*, and flashing or extinguished if there is a fault. The FBT-3 should not be used on the IS trunk, even within the safe area, without a gas clearance certificate which covers the whole system.

An operational system should have a green LED and two yellow LEDs permanently *on* and the red LED *off*.

If there is reason to believe that the FISCO power supply is defective then it can be further tested as follows. Disconnect the IS and host trunks and apply the FBT-5 to the host trunk connection (with the host power supply switched off) and monitor the output on the IS trunk with the FBT-3. In this arrangement, the yellow 'Host' LED flashes intermittently, but the FBT-3 functions adequately indicating that the FISCO power supply is functional. The ability of the FISCO power supply to communicate in one direction is checked by this interconnection.

Checking the communication from the IS trunk to the host trunk is marginally more difficult. The FBT-5 does not function in the presence of a second source of power, and consequently cannot be applied directly to the IS trunk terminals. The interaction between the two sources of power can be removed by coupling the FBT-5 to the IS trunk terminals via a capacitor and providing a separate resistive load to the FBT-5. The recommended practice is to couple the positive output from the FBT-5 to the positive IS trunk terminal via a $1\mu\text{F}$ non-polarised capacitor and load the output terminals of the FBT-5 with a $1\text{k}\Omega$ resistor. The two negative terminals should then be directly connected. The FBT-3 should be connected to the host terminals, with the host power supply switched in. If the communication facility of the FISCO power supply is functioning then this should be confirmed by satisfactory readings on the FBT-3.

4.5.3 Field devices

The host will normally provide a facility for listing the status of the field devices if the fault in the device does not pull down the whole network. If the network fails then the problem can usually be isolated by systematically disconnecting sections of the IS trunk. This is readily accomplished when the system uses Relcom Megablocks, which use plug in terminals. Where such a connection has an unused connector, this provides a useful point for monitoring the trunk voltage.

The majority of field devices have built in diagnostic tests, which can be addressed by the host. Consequently their failure can be quickly diagnosed and their isolation and removal readily accomplished. It is advisable to disconnect the field device spur at the connection block so as to remove the risk of shorting out the IS trunk during the maintenance operation.

4.5.4 IS Trunk

If it is thought desirable to measure the voltage and current in the IS trunk or its spurs, or their isolation from ground, this should only be done using a suitably approved multimeter.

4.5.5 Host and host trunk

The FBT-3 will usually provide all the information necessary to find any fault in the host trunk, which is usually only a simple interconnection. If the host develops a fault then the diagnostic procedure of the particular host should be followed. The use of the FBT-3 across the host trunk can yield useful information but the signal and noise level measurements are affected by their transition through the FISCO power supply and hence should be interpreted with that in mind.

5 CABLES AND ACCESSORIES

5.1 Cables

The choice of cables for use with fieldbus signals is not restrictive, and frequently existing cables can be used thus reducing installation costs. Where a 'gas clearance certificate' can be obtained the suitability of an existing cable can be checked by using the combination of the FBT-3 and FBT-5 testers as discussed in section 4. There are a number of cables specifically designed to carry the 31,25 kbit/s signal which usually follow the specification of the cable used in the conformance testing of fieldbus circuits. This is a 'single twisted pair cable meeting the following minimum requirements at 25°C.

- impedance at f_r (31.25 kHz) = $100\Omega \pm 20\%$ *
- maximum attenuation at $1.25 f_r$ (39 kHz) = 3.0 dB/km
- maximum capacitive unbalance to shield = 4nF/km, tested using a 30m or longer sample
- maximum d.c. resistance (per conductor) = 24 Ω /km
- maximum propagation delay change 0.25 f_r to 1.25 f_r = 1.7 μ s/km
- conductor cross sectional area (wire size) = 0,8 mm² (#18 AWG)
- minimum shield coverage shall be 90%

* f_r is the frequency corresponding to the bit rate

The IEC60079-27 standard requires that the IS trunk should have the cable parameters as already stated in Table 2. A typical instrument cable has parameters of 50 Ω /km, 0.8mH/km and 120nF/km and almost all instrument cables fall within the permitted parameters.

The use of a screened cable removes the necessity for segregation of the IS trunk from non-IS cables for safety reasons. Normally segregation is desirable to ensure that interference problems are minimised and clear identification of the cables is possible. Where colour is used to identify the cables it should be light blue. However the requirement is that the IS cables should be clearly identified, and this is possible using a number of other techniques.

5.2 Terminators

A terminator is a well-defined 100 Ω impedance that is placed at the start and end of a trunk cable. If this is not done the signal may be reflected, which reduces the wanted signal and causes unwanted spurious signals.

The 9121-IS or 9122-IS FISCO power supplies provide a repeater function, which has the effect of creating *two* separate fieldbus segments: one between the host control system and the FISCO power supply – the host trunk; and the other between the FISCO power supply and the field end of the intrinsically safe trunk – the IS field trunk.

Each of these segments must be terminated at both ends.

5.2.1 The Host trunk

Starting at the host end, a termination panel is frequently used, and this will include a fixed or a switchable terminator, which should be enabled. If a termination panel is not used, a separate terminator such as the FBT1-IS should be connected across the fieldbus wiring, close to the terminals of the host system.

At the other end of the host trunk, the FISCO power supply incorporates a switchable terminator – this is normally enabled. In applications where more than one FISCO power supply is connected in parallel to the host segment (thereby creating multiple hazardous-area segments), *only one of the power supplies has the host-side terminator enabled*. This is illustrated in Figure 26, where the terminator in the first unit is switched into circuit, while the terminator in the second is not.

5.2.2 The IS field trunk

The FISCO power supplies have a built-in terminator, permanently connected at the start of the IS field trunk.

The remote end of the IS trunk must also be terminated. A suitable terminator is sometimes included in fieldbus wiring hubs (e.g. some Megablock models), otherwise a separate terminator, such as the FBT1-IS, must be used.

The FBT1-IS is certified as Category II 1 in accordance with the ATEX 94/9/EC apparatus directive, and as EEx ia IIC T4 apparatus in accordance with the CENELEC IS standard EN 50020. The terminator has permitted input parameters as required by the FISCO standard and hence can be used in any FISCO circuit without any further consideration of the system safety.

Note: The terminator is also suitable for use in other fieldbus circuits, because of its wide range of permitted input parameters.

The FBT1-IS terminator provides an IP20 level of ingress protection and is intended for DIN rail mounting in an enclosure that provides adequate protection from the surrounding environment.

5.3 Interconnection blocks and enclosures

In almost all circumstances it is usual to connect individual instruments via spurs from the IS trunk, so that a particular instrument can be removed or replaced without interrupting the operation of the whole system. 'Daisy-chain' connections and the use of more than one wire per terminal are not the recommended practice for both serviceability and reliability reasons. The Relcom IS Megablock uses plug-in terminals which allow the IS trunk to be carried through the block and individual instruments to be spur connected to the IS trunk. Screws retain the plug-in terminals so as to ensure the integrity of the interconnection.

The Relcom Megablocks for applications in which spur short circuit protection is not required are FCS-MB2, FCS-MB4, FCS-MB8 and FCS-MB10-T, which cater for two, four, eight and ten spurs respectively. The 10-way version also incorporates a permanently connected terminator. These devices are certified as intrinsically safe EEx ia IIC T4 by LCIE under certificate number LCIE02ATEX6212X. In each case, the input safety parameters of the trunk connection are $U_i < 17,5V$, $I < 380mA$, $P < 5,32W$, $C_i = 0$ and $L_i = 0$, making the Megablocks suitable for use in FISCO systems. The voltage, current and power values are transferred directly to the spurs as U_o , I_o and P_o respectively, because the trunk and spurs are electrically connected in parallel.

Where spur short circuit protection is required, Megablock types F245 (4 way), F251 (8 way), F259 (10 way with fixed terminator-see Figure 18) or F261 (10 way with switched terminator) should be selected. These include the SpurGuard™ feature, which limits the current drawn on each spur and therefore prevents a shorted spur from bringing the whole trunk down. A red LED near each spur connection indicates that a spur is shorted and is in overcurrent mode. The trunk-to-spur voltage drop is typically 0,1V in 'untripped' mode; equivalent to a DC resistance of 5 Ω . □

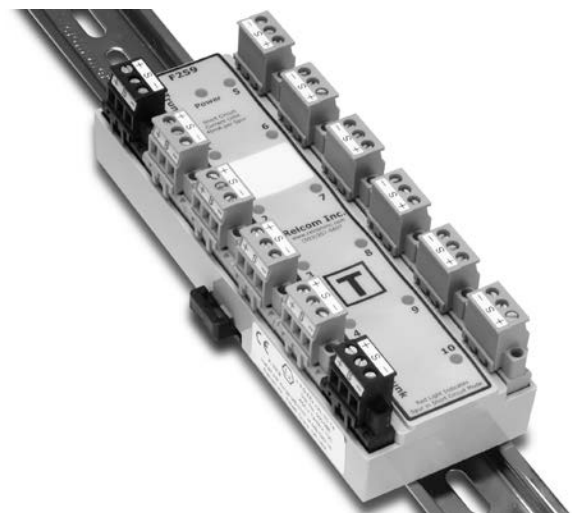

Figure 18 - Megablock F259 IS field termination block

Note that the current drawn by a spur in short circuit condition will be 42mA, so some margin should be included at the design stage to ensure that the power supply is not taken beyond its current capacity. It is normal to assume that only one spur will have a short circuit fault (as it is likely to be quickly rectified before another fault occurs), so an additional margin of 20-25mA is adequate.

The Megablocks provide the IP 20 ingress protection required by the intrinsic safety standard. The units are intended for DIN rail mounting within an enclosure which provides adequate protection against the environment in which it is mounted.

The principal requirement for mounting any intrinsically safe or associated apparatus is that the method of mounting should not allow the method of protection to be invalidated by any foreseeable contamination, mechanical damage, or unauthorised interference.

Usually the equipment in the safe area is mounted in conventional cabinets and there is no significant problem. In some circumstances, there may be a need to consider the temperature rise within a closely packed cabinet.

Where equipment is mounted in less favourable circumstances, for example in the field; a higher level of protection is required. When the enclosure is mounted in the hazardous area, the enclosure must meet the requirements of 'simple apparatus'. The enclosure materials should comply with the requirements of IEC 60079-0, which specifies the 'General Requirements' of apparatus used in hazardous areas. For example a plastic enclosure is required to have anti-static properties and some resistance to solar radiation. Although it is not specifically required, the most convenient way to ensure a satisfactory choice of enclosure in countries that follow IEC/CENELEC rules is to use an Exe (increased safety) component approved enclosure. The installation remains an IS installation and the enclosure needs to be clearly identified as containing IS circuits to ensure that maintenance procedures are correctly followed. A Division 2 approved enclosure may be selected in North America. The enclosure should be sufficiently large so that the contents are easily fitted and wiring can be easily connected. The space required for the tidy accommodation of wires is usually underestimated and sharp bends in wires are always undesirable but especially at low temperatures. Where the enclosure accommodates apparatus with plug in terminals, such as the Relcom Megablocks, extra space is required so that the plugs can readily be removed and the attached cables can flex as the plug is removed.

Space for the accommodation of glands, which allows them to be installed, is also required. It is desirable to drill holes to accommodate all the glands that will be required when all the spare capacity in the enclosure is utilised. Any holes intended for glands, which are not used initially, should be closed using blanking plugs, which maintain the IP rating of the enclosure. Accommodating the required number of glands frequently decides the size of the enclosure.

The choice of glands is decided by the requirement to be compatible with the cable used, to maintain the ingress protection of the enclosure and to comply with the spacing of the gland holes. Frequently, certified Exe glands are used since these are readily available and may be a site standard, but certification is not a requirement.

Consideration should be given to fitting breathing/drain devices to reduce the possible problems caused by condensation. Whether such devices are fitted is a decision relevant to a particular installation based on local knowledge, but it should be a conscious decision.

Elevation of the internal temperature of an enclosure is not a problem for enclosures containing only interconnection blocks. Enclosures containing power supplies will have an internal temperature rise, which is a function of the contents and layout of the enclosure. It is difficult to generalise about all the possible combinations, but allowing for an internal temperature rise of 15°C is a reasonable estimate for a metal enclosure, which is not tightly packed. The usual practice of avoiding excessive solar radiation by shading should be followed, and locating the enclosure so that easy access for installation and maintenance purposes is desirable.



Figure 19 – Examples from the MTL Process JB junction box range

The maximum permitted ambient temperature of the equipment determines the maximum external operating temperature. A T4 temperature classification is always achieved if the maximum permitted ambient temperature is not exceeded.

We have a range of field enclosures (see Figure 19) designed specifically for housing Megablock wiring components. Available in stainless or powder-coated steel, or carbon-loaded polyester material, the Process Junction Boxes can accommodate Megablocks of different sizes and are available with a choice of cable gland types. For more information visit www.mtl-ins.com.

6 SURGE PROTECTION

6.1 Introduction

This section discusses the protection of a FISCO system against electrical surges. Despite the increasing robustness of modern designs, damaging surges can come from a number of sources, of which the most common is from adjacent lightning strikes. In assessing the necessity for surge protection, it is important to recognise that fieldbus systems are susceptible to common mode failures that can close down the whole system. It is difficult to summarise the circumstances in which surge suppression becomes necessary but protection of all inputs to the system from external sources and all wiring runs within the system which are longer than 50m horizontal or 10m vertical should be considered. Lightning and surge protection for fieldbus systems is comprehensively discussed in MTL Surge application note TAN 1010 and this should be consulted for a more complete picture. It is important to recognise that surge damage does not always produce instantaneous failure. The long-term failures (six months) that appear intermittently at inconvenient times are frequently more expensive and always more difficult to find.

The use of surge protection devices (SPDs) on an intrinsically safe (IS) circuit results in the circuit being indirectly 'earthed' at more than one point, which is contrary to the normal practice for IS circuits. However the use of SPDs is an acceptable practice, which improves safety, and is covered by sections in the IS systems standard IEC 60079-25 and the code of practice IEC 60079-14. The MTL Surge application notes TAN 1004 and TAN 1005 consider the interaction between intrinsic safety and surge protection in more detail.

NOTE: The TANs mentioned in this section, other application notes on surge protection, and relevant data sheets can be obtained on line at www.mtlinsurge.com or from your local Eaton representative.

6.2 Compatible surge protection devices

Where an SPD is used on an IS fieldbus trunk or spur it must not have significant capacitance or resistance. The use of standard SPDs is unlikely to produce acceptable results and may not be safe. The capacitance of the SPD must be low (less than 100 pF) so as not to affect the safety analysis of the system or to attenuate the fieldbus. The resistance introduced must also be low (less than 1Ω), since a significant resistance would reduce the useable trunk length, which is already adversely restricted by the limitation on available current and energy imposed by the IS requirements. A resistance of a few ohms can also cause an impedance mismatch.

The two devices commonly used on the fieldbus trunks are:

a) The FP 32 (illustrated in Figure 20), which is a DIN rail mounted unit and is used as part of the wiring system when an enclosure or other protection against the environment is present. It is a series device and introduces a resistance of 0,5Ω into each lead. This resistance should theoretically be taken into account when deciding the available trunk length of a system (trunk cable loop resistance 50Ω/km), but can usually be ignored. The effective device capacitance is less than 50 pF and can be ignored from both an operational and safety viewpoint. The FP32 has provision for terminating and protecting the cable screen.

The FP 32 carries EEx ia IIC T4 and EEx ia IIB T3 intrinsic safety certification for connection into FISCO circuits power by the 9121-IS or 9122-IS. When used in a Zone 2 type 'n' circuit the FP32 acquires the type of protection of the circuit in which it is used, that is type 'nA' in a non-arcing circuit and type 'nL' in an energy-limited circuit.

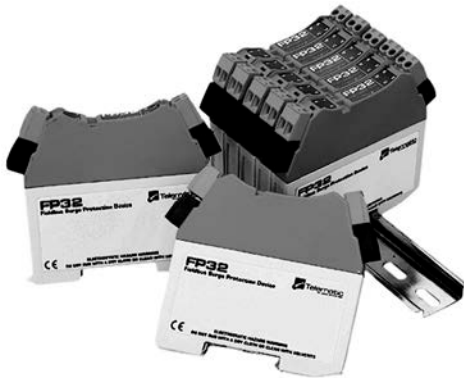

Figure 20 – FP32 Surge Protection Devices

b) The TP 32 (illustrated in Figure 21), which is mounted in a hexagonal stainless steel enclosure and is designed to be screwed into an unused port of a field mounted device. It is a parallel device and introduces no series resistance into the trunk or spur. Its effective capacitance is less than 50pF and hence is negligible.



Figure 21 - TP32 Surge Protection Devices

The TP32 device is certified ia IIC T4 to the CENELEC IS apparatus standard EN 50020 and meet the requirements of Category 1 equipment in accordance with the 94/9/EC (ATEX) Directive. It has negligible inductance and capacitance and $P_i = 5,32W$. It may therefore be connected into FISCO networks powered by the 9121-IS or 9122-IS. When used in a Zone 2 type 'n'

circuit the device is either 'nL' or 'nA' as decided by the circuit in which it is used.

c) The MA4000 (illustrated in Figure 22), which is the power supply SPD normally used with fieldbus applications. It is a parallel device that is easy to mount and has the additional advantage of meeting the requirements for Zone 2 or Division 2 mounting.

Full details of these devices are available on their respective data sheets.



Figure 22 - MA4000 Surge Protection Devices

6.3 Protecting the system

No two fieldbus installations will be the same, but the surge protection of any system can be considered by analysing the separate sections as illustrated by the simple system of Figure 23. A systematic progression through the possible sources of problems, and deciding what precautions (if any) are necessary is a desirable approach.

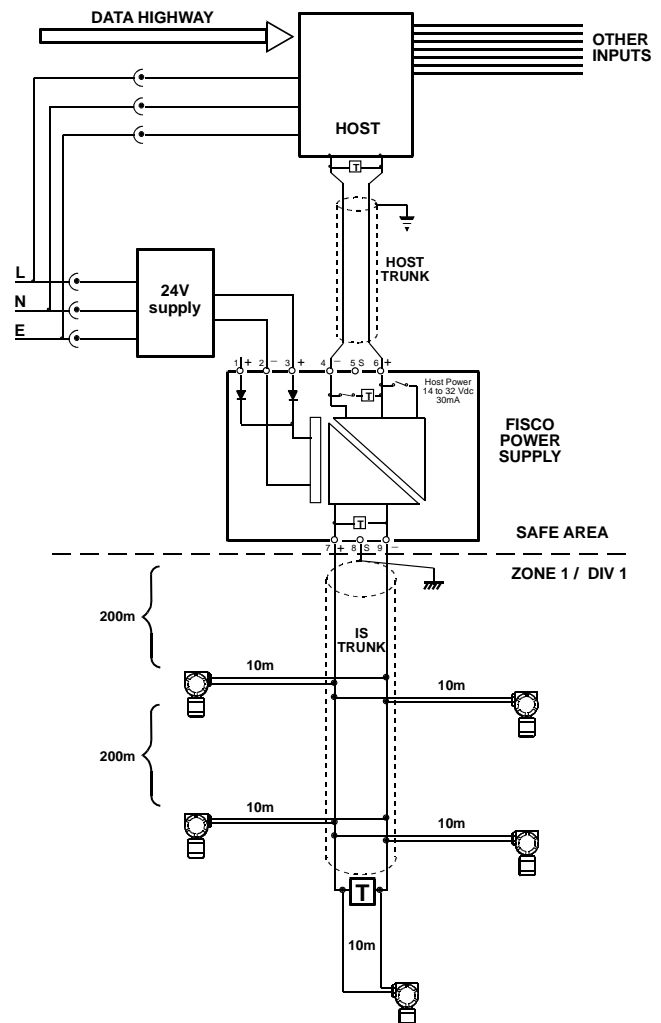

Figure 23 - Typical Fieldbus system

6.3.1 Host

The host has to be checked to ensure that it is protected from invasion via all its input connections because surges can cause significant damage beyond the immediate interconnecting interface.

The mains supply input is frequently subjected to surges either from adjacent lightning strikes or switching surges from other equipment connected to the system. Unless the supply is already part of a carefully protected supply, the use of a dedicated SPD is recommended. If the FISCO power supply is close then sharing the protected supply is a practical proposition. The MA 4000 is normally used as the dedicated protector.

The communications highway above the host controller normally requires protection, because it is quite frequently long and may even cross into equipment powered from a different distribution centre. The type of SPD required varies with the form of the data being transmitted.

The other data inputs should all be examined to establish whether they should be protected. Similarly connections to peripheral equipment should be examined even though they are unlikely to be a source of problems.

The host trunk is not likely to require protection if the FISCO power supply is close to the host, which is the usual situation when the two devices are in the safe area. If the FISCO power supply is moved away from the host, or if the host trunk is connected to other fieldbus elements then the host trunk terminals may need protection. The FP 32 is the preferred SPD for this purpose.

The 'earthing' or bonding of the SPDs associated with the host requires some care so as to maximise the effectiveness of the protection. Advice on the best techniques is given in TAN 1003.

6.3.2 24V supply

The mains supply to the 24V supply requires the same consideration as that of the host. If the supply is moved away from the host, and supplied from a field ring main, it will almost certainly require to be separately protected. The MA 4000 is the usual solution.

Normally the 24V supply and the FISCO power supply are mounted close together so as to avoid having significant voltage drop between the two devices and hence surge protection is not necessary. If the 24V supply is carried a significant distance and/or used to supply significant power to other apparatus then surge protection may be necessary. However this is not a usual installation.

6.3.3 FISCO power supply

The host trunk connection would only require protection at the FISCO power supply end in those less usual circumstances where the trunk connection to the host also requires protection. It is almost always the case that a cable needs to be protected at both ends since protecting one end invariably increases the problem at the other. The process is therefore to decide whether the trunk connection at the host needs protection. If it does then the connection at the FISCO power supply also needs to be protected. The FP 32 is the preferred solution.

The IS trunk connection normally needs protection if it is more than 100m long in the horizontal direction (even 50m should give pause for thought) or 10m in the vertical direction. This means that almost all installations need to be protected. The IS trunk illustrated in Figure 23 would require to be protected in almost any location in the world. The FP32 is the preferred solution.

6.3.4 Field devices

Where the field devices are spurred off the end of the trunk on short spurs in the way illustrated by the three devices in Figure 23 then they can all be protected by a single SPD at the point where the end of the IS trunk enters the junction box. The FP32 mounted in the junction box provides a solution. The FISCO system rules only allow spurs of up to 60m in length, and hence long spurs are not a reality. However if even a 60m spur was taken vertically up a vulnerable structure then a considerable voltage could develop between the field device and the junction box. The ideal solution is

to relocate the junction box so as to avoid the problem. Where this is not possible, it is better to forget the common protection of the field devices and protect them individually. A TP 32 protecting each of the three devices becomes the preferred solution. The two possibilities are shown in Figure 24.

The two devices located midway on the IS trunk are vulnerable to surges from both directions and the simplest solution is to abandon the possibility of common protection, and to individually protect the field devices using a TP 32.

The SPDs associated with field devices are usually bonded to the adjacent plant structure, which is part of the equipotential plane of the plant. This prevents local potential differences, which is the principal cause of damage and provides a path for the surge current.

6.3.5 Connecting blocks and terminators

The IS versions of the Relcom Megablock (FCS-MB4-IS and FCS-MB8-IS) are simple interconnection of terminals and will withstand large surge voltages (in excess of 10kV) both in common and series mode. The IS terminator is constructed so that it will withstand a high level of common mode surge voltage pulses and a 600V series mode pulse.

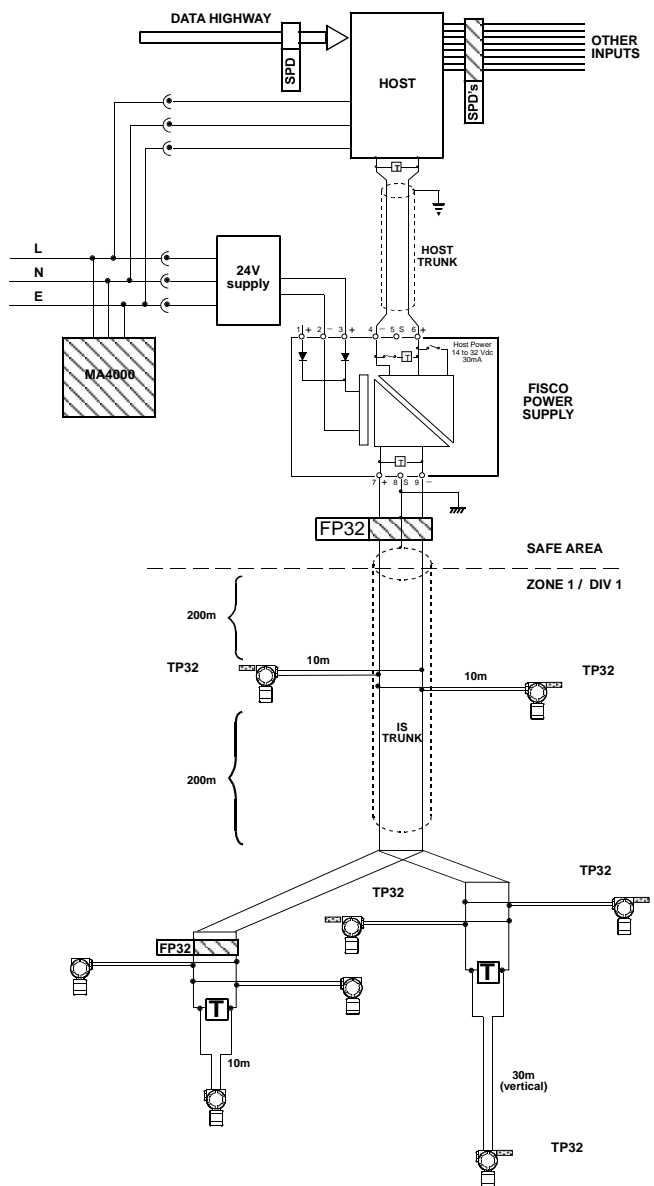

Figure 24 - Adequately protected Fieldbus system

When used in conjunction with field devices protected as described in the section above the connecting block and terminator are directly protected by the shared FP32 or indirectly protected by the surge protection of the TP32s on the field devices. The number of TP 32s and their relative positions with respect to the junction box

affects the protection offered by the TP32. However the residual surge should not damage the Megablock or terminator.

Figure 24 illustrates comprehensive surge protection of the system shown in Figure 23. It does not address the less frequently required protection of the host bus or the separate protection of the mains supply to the 24V supply, since these are straightforward modifications. The alternative techniques for protecting the three field devices at the end of the IS trunk are illustrated.

7 MOUNTING OF FISCO POWER SUPPLIES IN ZONE 2 AND DIVISION 2

7.1 General

There are a number of reasons why it might be thought desirable to mount the FISCO power supplies in a Zone 2 or Division 2 location. The most common is so as to use the power supply as a repeater thus extending the length of the trunk. This is usually a practical solution since Zone 1/Division 1 locations are normally quite small, and the power supply can be positioned in the larger Zone 2/Division 2 location so as to take full advantage of the permitted length of the host trunk.

7.2 Typical installation

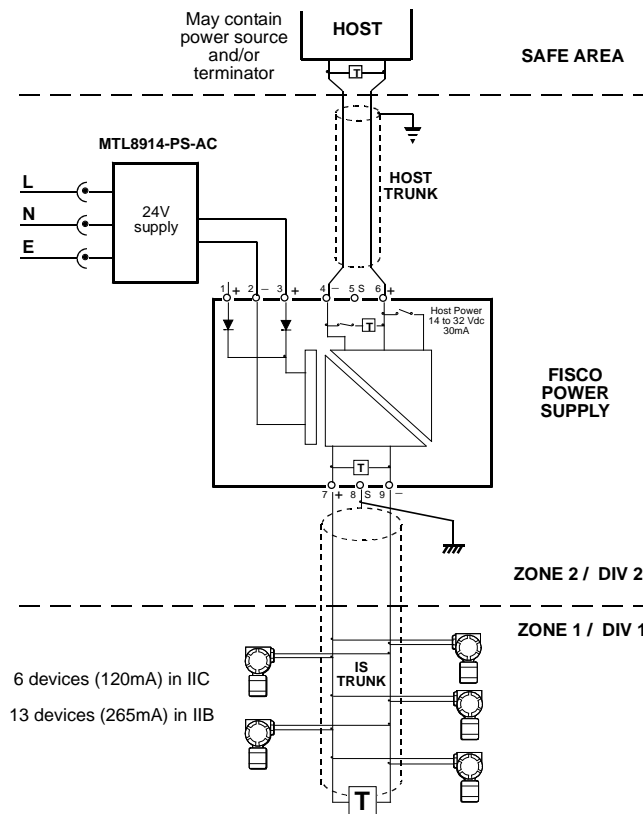

Figure 25 - Fieldbus power supply installed in Zone 2 or Division 2

Figure 25 illustrates the simplest installation of this power supply in a Zone 2 or Division 2 location. A host controller is connected to the non-intrinsically safe side of the power supply. In many circumstances the host would supply power to the bus and contain a terminator. In this case the FISCO power supply would have its terminator switched in and the internal host power supply not connected. When used in this mode, terminals 4 and 6 only draw a very small current (less than 4mA) and generate a signal current of ± 10 mA. In consequence the length of the host trunk is determined entirely by operational considerations (1,9km for a type A cable). The host trunk itself is usually non-arcing because the host controller is unlikely to have non-incendive approval and hence the cable must be mechanically protected from damage. The screened cable normally used for fieldbus trunks satisfies the requirements of non-arcing installations. It is not usual to provide an elaborate means of isolation or fusing for these low power cables because even under fault conditions the cable is not likely to suffer

overheating. Terminal blocks with "knife-edge" disconnects, or a plug and socket in the safe area are considered to be adequate. Although the cable is non-arcing the plug which contains terminals 4 and 6 can be disconnected without isolating the circuit because in normal operation it will always be carrying a non-incendive current. It should be noted that although the spark created by disconnecting this plug is non-incendive, shorting the host trunk may create an incendive spark. (The plug is constructed so that it is not easily short-circuited when it is disconnected). It is therefore not permissible to disconnect the host bus wiring without first disconnecting the host trunk in the safe area or isolating the supply.

The FISCO power supply requires a 24V supply, which can be derived from any convenient source. The isolation between the source of this power and the two fieldbus trunks removes any concern about interaction between the fieldbus system and other equipment connected to the 24V supply. Figure 25 shows the 24V supply being derived from MTL's 8914-PS-AC power supply, which is approved for mounting in Zone 2 and Division 2 locations. The potential output from the power supply is a nominal 10A and hence the interconnecting wiring (which would normally be within the same enclosure) is non-arcing, and is required to be secure. If this wiring is rated at 10A, the current limit in the power supply is adequate protection against overheating. The IIC FISCO power supply requires 190mA at 24V and this value is comfortably less than the permitted non-incendive value of 234mA. Similarly, a fully loaded IIB FISCO power supply requires 300mA at 24V and this is less than the 585mA permitted for a IIB non incendive supply. This permits the terminal plug on the FISCO power supply carrying the 24V supply to be disconnected without isolating that supply. Shorting the wiring from the 24V supply would create an incendive spark; it is therefore not permissible to disconnect the interconnecting wiring without first isolating the supply.

The mains supply can be derived from any convenient source, but must comply with Zone 2/Division 2 non-arcing requirements.

The installation of the intrinsically safe fieldbus trunk follows the usual requirements of such systems. The isolation from the 24V supply and the host trunk, provided by the FISCO power supply, removes any necessity to consider interaction between the intrinsically safe and the other circuits.

The screens of the buses are usually earthed or bonded at one end as illustrated in Figure 23. The host trunk screen is normally earthed at the host to the clean earth busbar. The IS trunk screen is normally bonded at the FISCO power supply to the structure or equipotential system via the enclosure bonding connection.

7.3 Mounting of the units in Zone 2 or Division 2

The fundamental requirement of mounting these units in Zone 2 or Division 2 is that they should be adequately protected from environmental effects, which can adversely affect their safety. Among the effects normally considered are protection from weather, contamination by dust or corrosive atmospheres, ambient temperature, solar radiation, mechanical impact and unauthorised interference. There is no universal solution applicable to all locations which is economic and practical, but there are some general guidelines which may prove helpful.

If the location is outdoors in a normal industrial location then the requirement is an enclosure which has a minimum ingress protection rating of IP54, an impact rating of at least 7Nm, and adequate resistance to corrosion. The usual solution is to use an Exn or Exe or Division 2 approved enclosure since this provides some assurance of suitability, and avoids having to be concerned about the effects of static and provision for bonding etc. If a reasonable size enclosure is chosen (frequently determined by the necessity to make provision for adequate glanding and making off of the field cables) then a temperature rise within the enclosure of less than 15°C can be expected. With the equipment under consideration then the temperature limitation under consideration is the ambient temperature limit of 70°C. This restricts the external ambient temperature of the box to 55°C, which is adequate for most locations provided that direct sunlight is avoided. The temperature rise inside the enclosure is not an entirely negative feature, since it does tend to prevent condensation while the equipment is turned on.

There are situations where these levels of ingress protection are not adequate, and the installer should be aware of these. For example in the offshore industry it is usual to specify enclosures which will withstand the deluge test. There are also installations where these levels of protection are not necessary, For example in some locations in the pharmaceutical industry there are Zone 2 or Division 2 areas that are clean and dry with restricted access and a standard 19-inch rack would be adequate. The decisive question is, "is the enclosure 'adequate for the purpose'?", and there is no single answer that fits all locations.

Temperature classification of this Zone 2/Division 2 installation is not a problem and would possibly justify a T6 (85°C) classification. However since almost all applications only require a T4 (135°C) classification the temperature classification is restricted to T4 at 70°C ambient since this is beyond any possible dispute.

7.4 Maintenance and fault finding

One of the disadvantages of non-arcing circuits is that usually working on the circuits without first isolating the circuit is not permitted. The alternative is to operate under a 'gas free clearance' certificate system (which is usually available in most hazardous locations) when the practices used in safe areas are acceptable.

In the particular case of the MTL FISCO power supply the plug-in terminals on the non-IS side of the unit can be disconnected without first isolating the supply, because the current normally carried is non-incendive and the risk of shorting the leads together is low. This facility used with the status LEDs on the FISCO power supply enables almost all of the diagnostic process to be carried out, before the circuit must be isolated. The intrinsically safe trunk may of course be live-worked without gas clearance.

Note: The terminal plugs can be withdrawn, but the leads should not be removed from the terminals without first isolating the system.

7.5 Further combinations

The host bus can be used to interconnect other fieldbus devices and systems. Theoretically up to 31 devices can be connected to the host bus. In practice the number is restricted by the capability of the port on the host controller and is normally restricted to 16. The FISCO power supply transfers the field device signals from the intrinsically safe bus to the host bus and consequently it is the total number of devices connected, either indirectly or directly, to the port which is relevant.

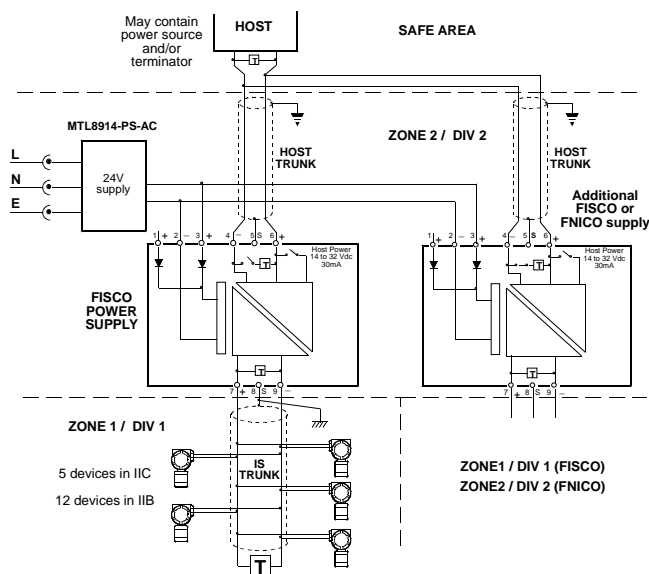

Figure 26 - Additional Fieldbus Power Supply Connected

Figure 26 illustrates the possible interconnection of a second power supply to the host bus. This power supply could be a FISCO power supply or another type of supply suitable for mounting in Zone 2 or Division 2 and providing power to Zone 2 or Division 2 field devices. In addition any suitably approved field device can be connected to the host bus provided that the usual operational requirements are

satisfied. The possible permutations are almost infinite, but considering the possibility of a second FISCO power supply as suggested in Figure 26 illustrates some of the possibilities.

The second FISCO power supply can share the 24V power supply and be housed in the same enclosure. Either power supply can be separated from the 24V power supply by unplugging the connector, which incorporates terminals 2 and 3, since this carries a non-incendive current. Since the FISCO power supplies require only a very small continuous current the length of the host bus is determined only by operational considerations. The total number of field devices connected to both FISCO power supplies must not exceed the capability of the host port. Only one of the two terminators available at the end of the host bus should be switched into the circuit.

8 CERTIFICATION AND SAFETY DOCUMENTATION OF FISCO SYSTEMS

8.1 Introduction

This section reviews the certification of the MTL FISCO power supplies in detail and the certification required of other components of the system. A major system simplification embodied in the FISCO technical specification is the simplification of the required documentation. The documentation of a hypothetical system is used to illustrate the relative simplicity of creating the required documentation.

The CE mark (which appears on all MTL products) indicates that the product conforms to all the relevant European Community (EC) directives, not just the ATEX directive.

Copies of all Eaton IS certificates and Category 3 documents of conformity can be obtained from EatonMTL. Many end-users prefer to store copies of apparatus certificates in some form, but it is desirable to consider dispensing with these files and using the web to obtain a current copy of the certificate, when and if it is needed. The UK notified body, the Electrical Equipment Certification Service (EECS), more commonly known as BASEEFA, closed down on October 1st 2002. A third UK notified body, Baseefa (2001) Ltd, has emerged from the closure and Eaton has transferred the relevant files to this organisation. This ensures that the original EECS certificates remain valid and will be administered by Baseefa (2001) Ltd in the future.

8.2 MTL FISCO power supplies

The 9121-IS power supply IS certification is covered by an EC-type examination certificate issued by EECS. The certificate is numbered BAS02ATEX7276 and requires that the apparatus be marked $\text{Ex II (2) GD [Ex ib] IIC (-40^\circ\text{C} \leq \text{Ta} \leq +70^\circ\text{C})}$. The first part of the marking relates to the ATEX directive and indicates that the apparatus is safe area mounted 'associated apparatus' suitable for connection to Category 2 surface industry equipment in both gas and dust atmospheres. The CENELEC standards, EN 50020 and EN50014, which are used to support the claim of compliance with the ATEX directive, require the remainder of the marking. This marking indicates that the apparatus is 'associated apparatus' suitable for connection to 'ib' circuits [normally used in Zone 1 locations] where the hazardous gas is classified IIC (hydrogen) and the permitted ambient temperature range of the apparatus is as indicated.

The ATEX Category 3 certification, which justifies the mounting of the FISCO power supply in Zone 2, is covered by an Eaton 'declaration of conformity' number MTL02ATEX9121X. This classifies the apparatus as II 3 GD, which translates as Category 3 apparatus (normally used in Zone 2) for use in surface industry in both gas and dust atmospheres. The marking relating to the CENELEC certification to the type 'n' standard is EEx nA IIC T4. The nA indicates the non-arcing construction of the power supply and the nature of the 24V supply and host trunk connections. Normally apparatus classified as 'nA' is not gas (apparatus) group sensitive but this apparatus is marked IIC because its IS output is gas group IIC. The T4 temperature classification corresponds to a maximum surface temperature of 135°C at the maximum ambient temperature of +70°C. This makes it suitable for use in all gases except carbon disulphide. The letter 'X' at the end of the certificate

number indicates that its safe use depends on special conditions being met, which are that the power supply must be installed in an enclosure appropriate to the gas or dust environment, and that it must be protected from large supply transients.

The 9122-IS power supply is certified in the same way as its companion power supply except that it is certified for gas group IIB [ethylene] which allows a greater output power, but excludes its use in association with IIC gases, which comprise hydrogen, acetylene and carbon disulphide. The corresponding IS certificate number is BAS02ATEX7277 and the Category 3 document number is MTL02ATEX9122.

The FISCO power supplies are also approved by FM Approvals Corporation (FM), under Project ID 30125710, as intrinsically safe to the FM standards, which are normally accepted in North America and elsewhere. The certification covers the use of the power supplies connected to hazardous areas that are classified in Zones (the IEC approach) as well as in those classified in Divisions (the more usual US approach). The power supplies are suitable for use in circuits which enter Division 1 because they meet the requirement for Division 1 associated apparatus. However the certification for use in installations that are classified using the Zone system is 'ib' and this restricts the connected circuits to Zone 1 locations unless additional precautions are taken. This is because the IEC standard does not permit active current limiting circuits in 'ia' systems.

The FM approval also covers the mounting of the power supplies in Class I, Division 2 or Zone 2 providing that the usual installation requirements are met.

The approval for the 9121-IS supply covers the use with Class I, Groups A,B,C,D T4 gases and IIC T4 gases and the 9122-IS supply is restricted to Groups C and D T4 and IIB T4 gases. The intrinsically safe output from both power supplies is approved by FM for use in Class II, Groups E (metal dusts), F (carbonaceous dusts), G (grain/other dusts) and Class III (fibers) in Division 1 locations. All the other requirements are the same as for the EECS certification.

Where a FISCO power supply is used in association with dust atmospheres, the 9122-IS supply should normally be used, since it provides additional power, but is still acceptably safe.

8.3 MTL terminator

The IS certification of the MTL fieldbus terminator type FBT1-IS covered by an EC- type examination certificate issued by Baseefa (2001) Ltd. The certificate number is Baseefa02ATEX0042 and requires that the apparatus be marked Ex II 1 G EEx ia IIC T4 (-40°C ≤ Ta ≤ +70°C). The FBT1-IS has input parameters:

$$U_i = 17,5V \quad I_i = 380mA \quad P_i = 5,32W$$

$$C_i = 0 \quad L_i = 0$$

and may therefore be used in FISCO systems powered by the 9121-IS or 9122-IS.

8.4 MTL 24V Zone 2/Division 2 power supply

The 8914-PS-AC power supply is certified as Category 3G in accordance with EN50021: 1999 and designated EEx nA II T4 by TÜV under certificate number TÜV01ATEX1774X, it may therefore be located in Zone 2 hazardous areas. It is also certified by Factory Mutual Research Co. (FM) as Class No. 3600/3611 for use in Class I, Division 2, Groups ABCD hazardous locations.

8.5 Cables

Cables are not required to be certified by the ATEX directive or by the IEC/CENELEC code of practice. They should comply with the requirements of the FISCO technical report. The majority of instrument cables fall well within the specified limits. Satisfactory evidence of compliance may be obtained from the cable manufacturer, or by testing a sample (at least 10m long) with a bridge using a frequency of 10kHz.

8.6 Enclosures and glands

Enclosures and glands do not need to be certified when used to protect IS apparatus. The requirement is to be 'adequate for the purpose', which is to protect the apparatus from contamination, mechanical damage and unauthorised interference. Frequently, Ex e component certified enclosures and glands are used so as to ensure adequate protection. However this is not a requirement.

8.7 Simple apparatus

The requirements of simple apparatus and its position under the ATEX Directive are discussed in Appendix I. In the particular case of FISCO systems, the total capacitance and inductance in the apparatus should not be greater than 5nF and 10µH separately.

8.8 Safety documentation

One of the merits of the FISCO system is the reduction of the safety documentation required. Because there is no necessity to carry out the compatibility tests and calculate the permitted cable parameters of the system in the same way as an entity concept system, the documentation can be reduced to a single table.

This is best illustrated by the example overleaf, which describes the 'typical installation' in Figure 27.

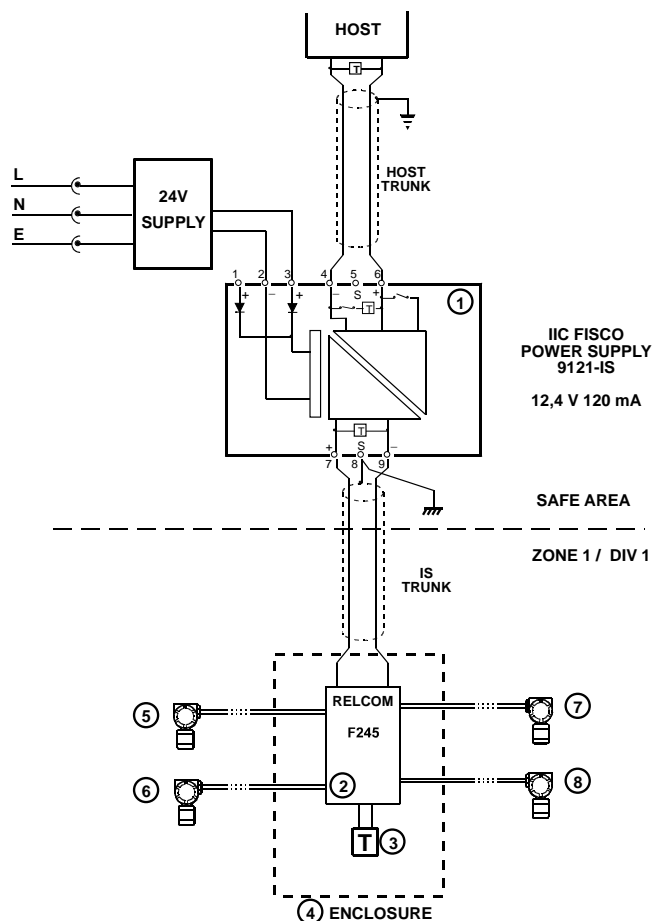

Figure 27 - Typical installation

A table is a possible solution, as shown. The table could also indicate the position of the equipment, but this is frequently done elsewhere. Details of choice of glands, installation of cables etc are usually covered by plant standards of the particular end-user.

The safety description document would normally be signed and dated by the person preparing the document and checked, signed and dated by a second person. Both signatories would be required to be trained and competent in this particular area of expertise.

Note: The system temperature range is determined by the cable specification and the 'ib' classification by the classification of the FISCO power supply.

8.9 Safety documentation for a FISCO system

System title *Typical Installation*

Conclusion

This safety document demonstrates that the FISCO system described satisfies the requirements of a IIC ib intrinsically safe system in which the field devices mounted in the hazardous area all have a T4 temperature classification and can be used in the ambient temperature range of -30°C to $+60^{\circ}\text{C}$.

Remarks

This document only considers in detail the IS power supply and the IS circuit. The apparatus connected to the safe area terminals of the FISCO power supply complies with the U_m : 250V requirement of that power supply and does not need to be further considered.

The cable used for the IS trunk and spurs is UNITRONIC BUS PA blue, type 2020234 T and has parameters compatible with the FISCO requirements, and has a useable temperature range of -30°C to $+60^{\circ}\text{C}$.

Equipment used

Item No.	Description	Manufacturer	Type Number	Classification	Certificate Number	Temperature Range
1	FISCO supply	Eaton	9121-IS	EEx [ib] IIC FISCO	BAS02ATEX7276	-40°C to $+70^{\circ}\text{C}$
2	Wiring hub	Relcom	F245 Megablock	Simple Apparatus		-45°C to $+70^{\circ}\text{C}$
3	Terminator	Eaton	FBT1-IS	EEx ia IIC T4 FISCO	Baseefa02ATEX0042	-40°C to $+70^{\circ}\text{C}$
4	Enclosure	Tincan	333OS	Simple Apparatus		-40°C to $+70^{\circ}\text{C}$
5	Temperature Transmitter	Hot	999C	EEx ia IIC T4 FISCO	ZZZ02ATEX 0001	-40°C to $+70^{\circ}\text{C}$
6	Pressure Transmitter	Bars	888P	EEx ia IIC T4 FISCO	YYY02ATEX0002	-40°C to $+70^{\circ}\text{C}$
7	Flow Transmitter	Wave	H2O	EEx ia IIC T4 FISCO	XXX01ATEX0003	-40°C to $+70^{\circ}\text{C}$
8	Valve positioner	Fixit	V55	EEx ia IIC T4 FISCO	WWWATEX0005	-35°C to $+65^{\circ}\text{C}$

Document compiled by
Jack Horner B.Sc C.Eng
April 1st 2002

Document checked by
Tom Piper M.Sc. M.B.A
11th Sept 2002

9 APPENDIX I: SIMPLE APPARATUS AND THE ATEX DIRECTIVE

9.1 Introduction

Simple apparatus has been in use as a valuable part of intrinsically safe systems for at least forty years, and the use of this apparatus has to be reassessed with the introduction of the two ATEX directives. The situation was explored in November 2000 at a meeting of the CENELEC sub-committee SC31-3 and the relevant technical advisor to the Brussels Directorate (Noel O'Riordan) and a statement which amplified the guidance given to the same committee in October 1999 was agreed. These two statements remain the accepted interpretation of the directive.

The original guidance was:

"Simple apparatus" will use the phrase from the directive "is not capable of causing an explosion through its own potential source of ignition" thus indicating but not stating that certification to the ATEX Directive is not required. That simple apparatus need not be marked in accordance with Clause 27 of EN 50014: 1997 will be stated."

The final agreed interpretation was:

"Simple apparatus is considered not to require certification by a notified body. The responsibility for compliance with the relevant parts of the standard rests with the persons claiming compliance, who may be a manufacturer or user. Certification to the ATEX Directive is not required because of the low levels of energy, which are added to the intrinsically safe circuit by this apparatus. Simple apparatus is required to be clearly identified when it is installed.

The intention is that simple apparatus is confined to pieces of apparatus which are fundamentally simple. Their safety should be readily verifiable by visual inspection and reference to available data by a competent engineer.

Where a manufacturer considers that certification by a notified body is desirable then this is permitted. In these circumstances, the apparatus shall be certified in the same manner as more complex apparatus in accordance with EN 50020 and the ESRs of the ATEX Directive and be marked accordingly."

The intention of these two statements has been carried through into the apparatus and system standards, and are the accepted interpretation of the ATEX directive on this subject.

9.2 Standards

The most recent apparatus standard is the CENELEC standard EN50020: 2002, which details the requirements of simple apparatus in clause 5.4. This clause is reproduced in full in Appendix II but the complete standard needs to be consulted for comprehensive understanding because of the numerous cross references. The only difference from the IEC requirement in IEC60079-11 is that the clause requiring compliance with the Category 1 standards has been added.

The new IEC/ CENELEC standard IEC 60079-25 was published early in 2005; the system standard is not directly relevant to the ATEX apparatus directive, but is utilised when producing documentation for the risk analysis required by the user directive. The system standard does not make any specific reference to the inclusion of simple apparatus but it is necessary to include the known inductive and capacitive parameters (as indicated in clause 5.4b) of EN 50020) in the assessment of the system. In the specific case of a FISCO system, the simple apparatus should have an inductance not greater than 10mH and a capacitance not greater than 5nF, and can then be regarded in the same way as any field device. The 1.5V, 100mA and 25mW limitation is normally considered to apply to the total capability of all the simple apparatus within a single system. Apparatus conforming to these limitations can be added to an intrinsically safe system without the necessity to reconfirm the safety analysis of the system. The system standard does confirm the requirement to clearly identify the simple apparatus and suggests that the minimum requirement is 'a traceable plant identification label'.

9.3 Conclusion

The continued use of simple apparatus in intrinsically safe circuits is compatible with both ATEX directives and the relevant Brussels's directorate has confirmed this. The accepted current practice remains unchanged

Note: The USA still uses the older definition of simple apparatus with the '1,2V, 100mA, 25mW and 20µJ' limitations. This makes very little practical difference but has to be taken into account if a system for world-wide use is being designed.

10 APPENDIX II: EXTRACT FROM BS EN 50020: 2002

5.4 Simple apparatus

The following apparatus shall be considered to be simple apparatus:

- Passive components**, for example switches, junction boxes, resistors and simple semiconductor devices
- Sources of stored energy with well-defined parameters**, for example capacitors or inductors, whose values shall be considered when determining the overall safety of the system;
- Sources of generated energy**, for example thermocouples and photocells, which do not generate more than 1,5V, 100mA and 25mW. Any inductance or capacitance present in these sources of energy shall be considered as in b).

Simple apparatus shall conform to all relevant requirements of this standard but is not considered to contain a potential source of ignition capable of causing an explosion and need not be marked in accordance with clause 12. In particular, the following aspects shall always be considered:

- Simple apparatus shall not achieve safety by the inclusion of voltage and/or current-limiting and/or suppression devices;
- Simple apparatus shall not contain any means of increasing the available voltage or current, for example circuits for the generation of ancillary power supplies;
- Where it is necessary that the simple apparatus maintains the integrity of the isolation from earth of the intrinsically safe circuit, it shall be capable of withstanding the test voltage to earth in accordance with 6.4.12. Its terminals shall conform to 6.3.1;
- Non-metallic enclosures and enclosures containing light metals when located in the hazardous area shall conform to 7.3 and 8.1 of EN 50014;
- When simple apparatus is located in the hazardous area, it shall be temperature classified. When used in an intrinsically safe circuit within their normal rating and at a maximum ambient temperature of 40°C, switches, plugs, sockets and terminals can be allocated a T6 temperature classification for Group II applications. Other types of simple apparatus shall be temperature classified in accordance with clauses 4 and 6 of this standard;
- Where simple apparatus is to be located such that Category 1 G or M1 equipment is normally required, then the apparatus shall also comply with the additional requirements of EN 50284 or EN 50303 as applicable.
- Where simple apparatus forms a part of an apparatus containing other electrical circuits, then the combination of apparatus shall be considered as a whole.

NOTE Sensors, which utilise catalytic reaction or other electro-chemical mechanisms, are not normally simple apparatus. Specialist advice on their application should be sought.

AUSTRALIA

MTL Instruments Pty Ltd,
10 Kent Road, Mascot, New South Wales, 2020, Australia
Tel: +61 1300 308 374 Fax: +61 1300 308 463
E-mail: mtl-salesanz@eaton.com

BeNeLux

MTL Instruments BV
Ambacht 6, 5301 KW Zaltbommel
The Netherlands
Tel: +31 (0)418 570290 Fax: +31 (0)418 541044
E-mail: mtl.benelux@eaton.com

CHINA

Cooper Electric (Shanghai) Co. Ltd
955 Shengli Road, Heqing Industrial Park
Pudong New Area, Shanghai 201201
Tel: +86 21 2899 3817 Fax: +86 21 2899 3992
E-mail: mtl-cn@eaton.com

FRANCE

MTL Instruments sarl,
7 rue des Rosiéristes, 69410 Champagne au Mont d'Or
France
Tel: +33 (0)4 37 46 16 53 Fax: +33 (0)4 37 46 17 20
E-mail: mtlfrance@eaton.com

GERMANY

MTL Instruments GmbH,
Heinrich-Hertz-Str. 12, 50170 Kerpen, Germany
Tel: +49 (0)22 73 98 12-0 Fax: +49 (0)22 73 98 12-2 00
E-mail: csckerpen@eaton.com

INDIA

MTL India,
No.36, Nehru Street, Off Old Mahabalipuram Road
Sholinganallur, Chennai- 600 119, India
Tel: +91 (0) 44 24501660 /24501857 Fax: +91 (0) 44 24501463
E-mail: mtlindiasales@eaton.com

ITALY

MTL Italia srl,
Via San Bovio, 3, 20090 Segrate, Milano, Italy
Tel: +39 02 959501 Fax: +39 02 95950759
E-mail: chmninfo@eaton.com

JAPAN

Cooper Crouse-Hinds Japan KK,
MT Building 3F, 2-7-5 Shiba Daimon, Minato-ku,
Tokyo, Japan 105-0012
Tel: +81 (0)3 6430 3128 Fax: +81 (0)3 6430 3129
E-mail: mtl-jp@eaton.com

NORWAY

Norex AS
Fekjan 7c, Postboks 147,
N-1378 Nesbru, Norway
Tel: +47 66 77 43 80 Fax: +47 66 84 55 33
E-mail: info@norex.no

RUSSIA

Cooper Industries Russia LLC
Elektrozavodskaya Str 33
Building 4
Moscow 107076, Russia
Tel: +7 (495) 981 3770 Fax: +7 (495) 981 3771
E-mail: mtlrussia@eaton.com

SINGAPORE

Cooper Crouse-Hinds Pte Ltd
No 2 Serangoon North Avenue 5, #06-01 Fu Yu Building
Singapore 554911
Tel: +65 6 645 9864 / 5 Fax: +65 6 487 7997
E-mail: sales.mtlsing@eaton.com

SOUTH KOREA

Cooper Crouse-Hinds Korea
7F, Parkland Building 237-11 Nonhyun-dong Gangnam-gu,
Seoul 135-546, South Korea.
Tel: +82 6380 4805 Fax: +82 6380 4839
E-mail: mtl-korea@eaton.com

UNITED ARAB EMIRATES

Cooper Industries/Eaton Corporation
Office 205/206, 2nd Floor SJ Towers, off. Old Airport Road,
Abu Dhabi, United Arab Emirates
Tel: +971 2 44 66 840 Fax: +971 2 44 66 841
E-mail: mtlgulf@eaton.com

UNITED KINGDOM

Eaton Electric Ltd,
Great Marlings, Butterfield, Luton
Beds LU2 8DL
Tel: +44 (0)1582 723633 Fax: +44 (0)1582 422283
E-mail: mtlenquiry@eaton.com

AMERICAS

Cooper Crouse-Hinds MTL Inc.
3413 N. Sam Houston Parkway W.
Suite 200, Houston TX 77086, USA
Tel: +1 281-571-8065 Fax: +1 281-571-8069
E-mail: mtl-us-info@eaton.com